

PowerPack 2000S

Manual for Installation and Operation



photo may differ from actual product

1 Introduction

Thank you for purchasing a LORENTZ product.

Before you begin – Please check the product label to verify that this is the item you ordered. To ensure the product is appropriate for your application please check the product specifications.

In addition to this manual, manuals for the pump end, controller and all other components used in your system should also be read.

2 Safety Instructions

Safe operation of this product depends on its correct transportation, operation and maintenance. Failure to follow these instructions can be dangerous to life or health and/or void the warranty.

PLEASE READ AND FOLLOW ALL INSTRUCTIONS!

Explanation of warning symbols



WARNING – Disregard can lead to injury, death or damage the system.



CAUTION – Recommended to avoid damage, premature aging of the pump or similar negative consequences.

When installing and using this electrical equipment, basic safety precautions should always be followed, including the following:



WARNING – To reduce the risk of injury, do not permit children to use this product.

WARNING – The equipment is not to be used by persons (including children) with reduced physical, sensory or mental capabilities, or lack of experience and knowledge, unless otherwise instructed and closely supervised.

WARNING – It must be ensured that all grounding connections are properly made and that the resistance towards ground meets local codes and requirements.

WARNING – To reduce the risk of electric shock, replace any damaged cords and cabling immediately.

This manual contains basic instructions which must be observed during installation, operation and maintenance. The manual should be carefully read before installation and use of the product by the person in charge of the installation. The manual should also be read by all other technical personnel/operators and should be available at the installation site at all times.

Personnel qualification and training - All personnel responsible for the operation, maintenance, inspection and installation must be fully qualified and trained. Responsibility, competence and the supervision of such personnel must be strictly regulated by the user. Should the available personnel be lacking the necessary qualification, they must be trained and instructed accordingly. If necessary, the operator may require the manufacturer/supplier to provide such training. Furthermore, the operator/user must ensure that the personnel fully understand the content of the manual.

Safe operation – The safety directions in this manual, existing national regulations for the prevention of accidents as well as internal guidelines and safety regulations for the operator and user must be followed at all times.

General safety directions for the operator/user – Protective covers for moving parts (e.g. couplings) must not be removed when the equipment is running. Leaks (e.g. at the shaft seal) of hazardous pumping media (e.g. explosive, toxic, hot liquids) must be disposed of in such a way that any danger to personnel and the environment is avoided. All government and local regulations must always be followed. Any danger to persons from electrical energy must be eliminated by using proper installation practices which must be in accordance to local regulations (e.g. VDE in Germany).

Safety directions for maintenance, inspection and assembly work – It is the user's responsibility to ensure that all maintenance, inspection and assembly work is performed exclusively by authorized and qualified experts who are sufficiently informed through reviewing the operating instructions.

Local accident prevention regulations must be observed. All work on the equipment should be done when it is not being operated and ideally electrically isolated. The sequence for shutting the equipment down is described in the manual and must be strictly observed. Immediately upon completion of the work, all safety and protective equipment must be restored and activated.

Unauthorized changes and manufacturing of spare parts – Any conversion or changes of the equipment may only be undertaken after consulting the manufacturer. Original spare parts and accessories authorized by the manufacturer guarantee operational safety.

Using unauthorized parts may void any liability on the part of the manufacturer. Configuring the schemes in this way ensures flexibility in the future if local management changes.

Unauthorized operation – The operational safety of the equipment delivered is only guaranteed if the equipment is used in accordance with the directions outlined in this manual. Limits stated in the datasheets may not be exceeded under any circumstances.

Cited standards and other documentations – DIN 4844 Part 1 Safety marking; Safety symbols W 8, Supplement 13; DIN 4844 Part 1 Safety marking; Safety symbols W 9, Supplement 14

RETAIN THESE INSTRUCTIONS FOR FUTURE USE!

3 Specifications

Table 1: Specifications

Product Name	PowerPack PP2000S
Item No.	19-001057
Pump Systems	PS2-1800 / PS2-600
AC Input Voltage	Single phase 200-240 V AC (±10%)
AC Current	20 A / 180 V AC 16 A / 230 V AC*
Frequency	47-63 Hz
PV Input PS2-1800	Max. 200 V DC (solar)
PV Input PS2-600	Max. 150 V DC (solar)
DC Output PS2-1800	up to 200 V DC (solar) 160 V DC (PowerPack) 12-14 A
DC Output PS2- 600	up to 150 V DC (solar) 135 V DC (PowerPack) 12-14 A
Working Ambient Temp.	-20~ + 45°C (-4°F to 113°F)
IP Class	IP33
Remote Control	On-Off control function
Protections	Short circuit, overload, over voltage, over temperature and fan failure

*An AC breaker on the PP input must be installed. The AC breaker must meet local regulations.

Additional certification concerning the inbuilt power supply:



4 Application

The LORENTZ PowerPack 2000S allows the pump to be powered by an AC power supply from the grid or a generator. Typical uses are for powering the system overnight or for meeting higher water demands in low solar power situations. The switch from solar to AC happens automatically when turning on the PowerPack. If the AC power source is switched off, the PowerPack will return to operating from solar power.

If PV is disconnected, a separate timer switch can be used to control the AC power supply to the PowerPack in cases where scheduled use of the PowerPack is necessary (e.g. to extend pumping time). The PowerPack can be remotely activated through its remote-control terminals by means of a separate switch or a contact signal. Further details can be found in section 4.2.

Figure 1: System layout

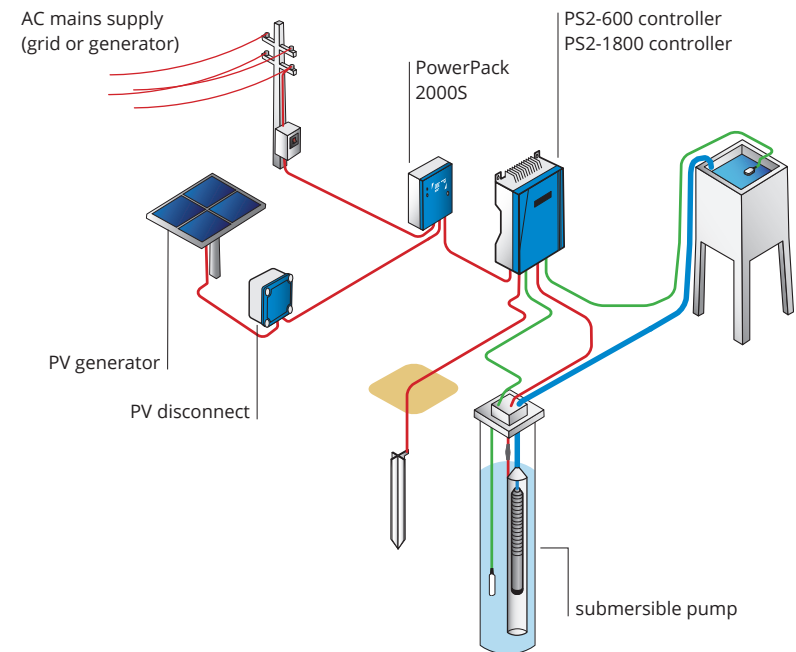

4.1 IMPORTANT - Using PP2000S with PS2-600

WARNING - Before changing power sources, the PowerPack and controller must be switched off and the AC and DC power sources must be disconnected.

WARNING - The following feature should only be operated by qualified personnel.

The PP2000S is delivered with default settings for PS2-1800 systems. If you are using the PowerPack with a PS2-600 system then please adjust the voltage as described below and in table 2.

Position 1 is for PS2-600 and Position 4 is for PS2-1800.

Table 2: Optional voltage selection

Voltage selection	DC voltage value	Description
Pos 1.	135 V	Mandatory position for all the PS2-600 pump systems
Pos 4.	160 V	Default position for all the PS2-1800 pump systems

Figure 2: Voltage switch selector



The default selector position should only be changed when using this PowerPack with a PS2-600 system. COMPASS can be used to check the expected performance of your system based on the selected voltage setting.

4.2 Remote on/off function

This PowerPack includes a normally open (NO) terminal for remote control. Closing the contact between the remote on/off terminals will switch off the DC output of the PowerPack.

The PP2000S allows 24/7 operation of the LORENTZ PS2-1800 / PS2-600 pump systems by connecting the output switch of the controller to the remote on/off terminals in the PowerPack. This is shown in figure 3.

Figure 3: PP2000S remote on/off wiring

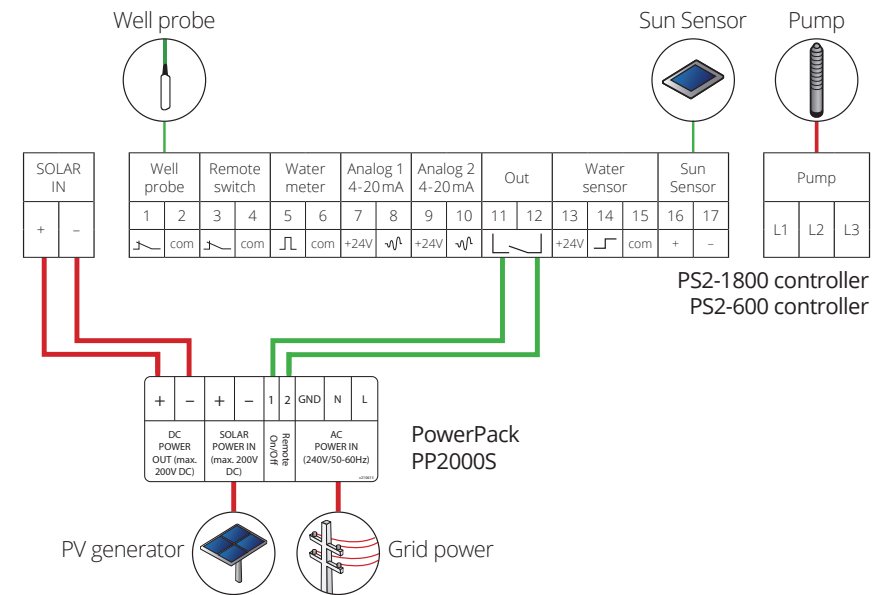
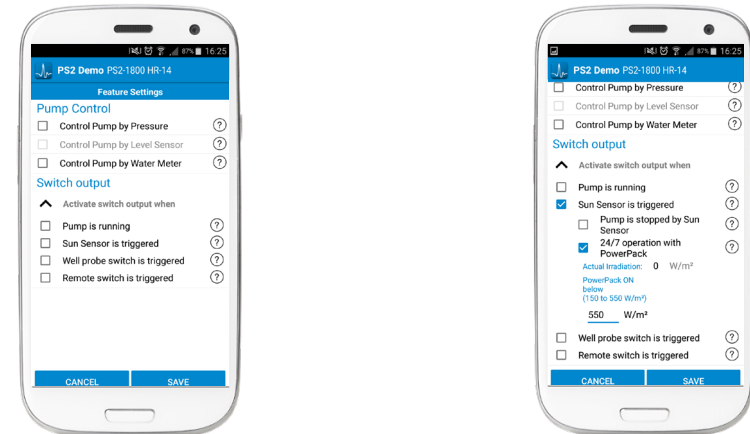

Figure 4: PumpScanner feature settings and 24/7 operation configuration



CAUTION - A Sun Sensor must be installed and configured for 24/7 operation.

CAUTION - AC power must be available at all times to prevent the pump from running with insufficient power (e.g. idling).

Configure the PS2 controller with PumpScanner as instructed in the PS2 and PumpScanner manuals. To configure automatic switching of the power supply between solar and grid power navigate to "Feature Settings" in PumpScanner and expand the "Switch output".

Under the tab "Sun Sensor is triggered", select "24/7 operation with PowerPack". Define the irradiation threshold for which the PowerPack should be activated. See figure 4 for examples.

The wires for connecting the switch output of the PS2 controller with the remote on/off terminals of the PP2000S must be 1 mm² (AWG18) or larger.

5 Installation



WARNING - This device must be installed, connected and serviced by qualified personnel only. Ensure all power sources are disconnected when making connections to this unit. Follow all appropriate electrical codes.

WARNING - For best performance and to avoid over temperature shut off, install the PowerPack in a location that is shaded from direct sun. Allow free air circulation around the ventilation openings on the side and bottom of enclosure.

5.1 Mounting

The PowerPack should be mounted on a wall or panel close to the pump controller in a vertical position. The unit must be protected from direct rainfall and direct sunlight.

Fixing pattern for holes: 310 x 292 mm / 12.2 x 11.5 in

Figure 5: Product dimensions

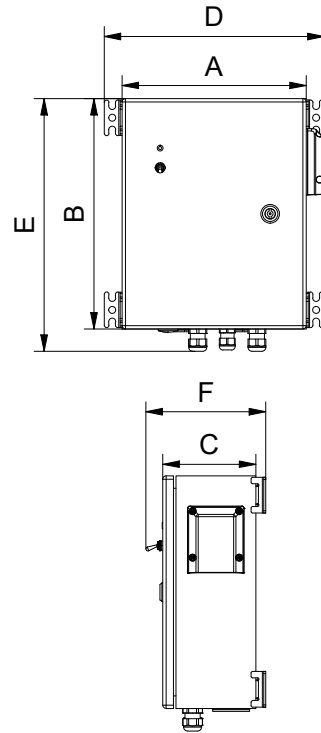

Dimensions						
	A	B	C	D	E	F
mm	280	350	140	334	384	180
in	11	13.8	5.5	13.1	15.1	7.1

5.2 Connections and wiring



WARNING - Beware of high voltage! Hazardous electricity may be present and can shock, burn or cause death! Only authorized and qualified personnel should operate the system.



CAUTION - The PowerPack should only be connected to power after correct wiring or the controller may be damaged.

CAUTION - Do not connect any electrical load to the PV generator other than the LORENTZ pump controller and PowerPack. Connecting the battery charger, active solar tracker controller, electric fence charger or other loads simultaneously with LORENTZ PS2 systems may interfere with the controller and prevent proper operation.

CAUTION - Measure the voltage before connecting power to the PowerPack. Follow the guidelines included in this manual regarding maximum PV input voltages.

CAUTION - Do not connect the PV modules to the DC output as it may damage the PV modules.

DC Solar Input - Connect the PV modules to "SOLAR POWER IN", paying close attention to the polarity. Check the voltage from the PV generator. The voltage must not exceed the open circuit values listed in table 3 below.

Table 3: Maximum PV input

Controller	PP2000S
PS2-600	150 V DC
PS2-1800	200 V DC

Every solar pump system must be equipped with a properly sized DC disconnect switch. The switch must be installed between the PV generator and the PowerPack.

AC Input - Connect AC power to the terminals (L) line and (N) neutral. Before connecting to grid, check that the grid connection is properly protected with a fuse and if required with an ELCB (Earth leakage circuit breaker). All electrical connections must meet local and national electrical standards.

Grounding - Ensure the PowerPack is correctly grounded to meet local and national electrical guidelines. The dedicated GND terminal on the AC input is the grounding connection.

DC power out - Connect the Powerpack DC OUT via an appropriate DC disconnect (or PV disconnect) to the POWER IN + - terminals of the PS2 controller.

6 Operation

Connect the AC power source and switch on the PowerPack AFTER it has been connected to the pump controller. When the controller and the PowerPack are switched on, the system light should flash on the controller and the pump should start. When the PowerPack is switched OFF (or its AC source is disconnected), the system will run with the PV power available. If the LED indicator is on this means that the PowerPack is activated.

7 Maintenance

This is a maintenance free device with no user-serviceable parts inside. If you need assistance please contact qualified service personnel.

8 Troubleshooting

Before contacting service personnel with troubleshooting questions, please follow the steps outlined in table 4.

Table 4: Troubleshooting guide

No output or LED on	Check that the input has been connected to a stable AC supply
	Check that PV power is present
	Check that the bottom PP2000S switch is in the "On" position
Pump is not running with PP2000S	Check proper connections in terminals
	Check for possible errors using PumpScanner
	Check AC and PV supply
	Check DC polarity on the controller side
'Overvoltage' warning in PumpScanner with PS2-600 controller	Check wiring in general
	Check that both the PowerPack and controller are switched on
	Ensure that PV open circuit voltage is appropriate (see section 5.2)
Pump is running at low power during PowerPack operation	Check the output voltage setting; choose lower voltage setting (see section 4.1)
	Check ambient temperature and ensure that the PowerPack has proper ventilation
	Check the output voltage setting (see section 4.1)

Test the controller using PV power. If there are still problems follow the PS2 troubleshooting guide.

Sun. Water. Life.

LORENTZ 

www.lorentz.de