

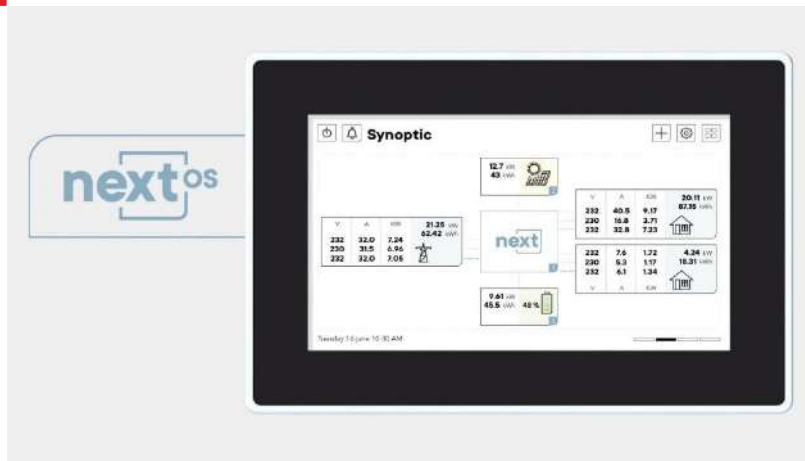

swiss made power

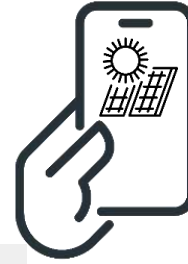

nextOS

Interfaces and environment for operating the next3 and next1 systems.

- nx-interface
- embedded webserver for smartphones, tablets and computers



Table of contents

1	Introduction	5
2	General information	6
2.1	About this manual	6
2.1.1	Versions	6
2.2	Legal provision	7
2.2.1	Software licenses	7
2.3	Important safety instructions	7
2.4	Technical support	7
2.5	Quality and warranty	8
2.5.1	Exclusion of warranty	8
2.5.2	Exclusion of liability	8
2.6	Conventions	9
2.6.1	Glossary	9
2.6.2	Symbols and conventions	9
3	HMI: Use of nx-interface	10
3.1	General navigation and use	11
3.1.1	Screens map	12
3.1.2	Embedded documentation	14
3.1.3	Accessibility	16
3.2	Displaying the state of the energy system on the nx-interface	18
3.2.1	Simple dashboard	18
3.2.2	Synoptic	20
3.2.3	Simple chart	23
3.2.4	Messages	24
3.3	The nx-interface functionalities	25
3.3.1	Remote Control	26
3.3.2	Update	28
3.3.3	Installation Configuration	31
3.3.4	Monitoring & dataloging	33
4	HMI: Local web interface via webserver	41
4.1	First commissioning with web access point (nx1)	42
4.2	Access with the nx-interface	44
4.3	Use of the web interface	45
4.4	DNS troubleshooting: "page not found"	46
4.5	Limitations of the embedded webserver	47
4.6	Use of webinterface as private remote monitoring	47
5	Configuration and operation of the energy system	48
5.1	Essentials to know about a next3 and next1 systems	48
5.1.1	Understand the General Energy Strategy	50
5.1.2	Standard use cases	52

5.2	Configuration / Commissioning	54
5.2.1	Configuration storage in memory	54
5.2.2	Before first commissioning	55
5.2.3	The Wizard explained step by step	56
5.3	AC-Source	68
5.3.1	General information	68
5.3.2	AC-source Information	68
5.3.3	AC-source Settings for Grid	71
5.3.4	AC-source Settings for Genset	76
5.4	Solar PV (for next3)	77
5.4.1	General information	77
5.4.2	Solar Information	78
5.4.3	Solar Settings	80
5.5	Battery	82
5.5.1	General information	82
5.5.2	Battery Information	82
5.5.3	Battery Settings	84
5.5.4	Battery: additional explanations	86
5.6	AC-Loads	98
5.6.1	General information	98
5.6.2	AC-Loads Information	98
5.6.3	AC-Loads settings	99
5.7	AC-Flex	101
5.7.1	General information	101
5.7.2	AC-Flex as source: information and settings	101
5.7.3	AC-Flex as Loads: information	102
5.7.4	AC-Flex as load: Settings	103
5.8	System settings	111
5.8.1	Neutral and earthing relay	111
5.8.2	Source priority	113
5.9	Device and I/O: Aux contacts, Inputs and communication	114
5.9.1	General points	114
5.9.2	Device Information	115
5.9.3	AUX-contacts settings	116
5.9.4	IN-CMD settings	118
5.9.5	RS485i Settings	119
6	Special applications	120
6.1	AC-coupling / AC-solar	120
6.1.1	General system design	120
6.1.2	AC-coupling with frequency shift	121
6.1.3	Simplified AC-coupling (no island mode) with AC-Flex	125
6.1.4	Example of use	130
6.2	DC-coupling/DC-solar: integration of Studer solar chargers vario in the system	131
6.2.1	Xcom485i-nx configuration	131
6.3	next3 external bypass for redundancy	133
6.3.1	Simple manual bypass	134
6.3.2	Automatic bypass	135
6.4	External control of the next1/3 by SCADA or API	136

6.4.1	The Object Model	136
6.4.2	Static IP for MODBUS TCP	138
6.4.3	Securities in case of external control	139
6.4.4	Properties/registers to control	141
6.4.5	Example of control of next3 in function of an external smartmeter	142
6.4.6	Example of control for dynamic electricity prices	143
7	Maintenance of the installation	145
7.1	Software update	145
7.1.1	Automatic update download (from version 1.3.0.0)	146
7.1.2	Non-automatic update download (from version 1.2.0.0)	146
7.1.3	USB key update (older versions or without internet)	146
7.1.4	During and after the update:	147
7.1.5	Troubleshooting: update menu not available	148
8	Nx-interface technical data	149
8.1	Mounting of the nx-interface	149
9	Product recycling	151
10	Conformity	151
10.1	Notes on grid codes	151

1 Introduction

Welcome to the world of Studer products for renewable energy production, conversion and management. Studer-Innotec supplies inverters, inverters-chargers, hybrid inverters, solar MPPT chargers to build sustainable energy systems for OFFGRID system and ONGRID systems.

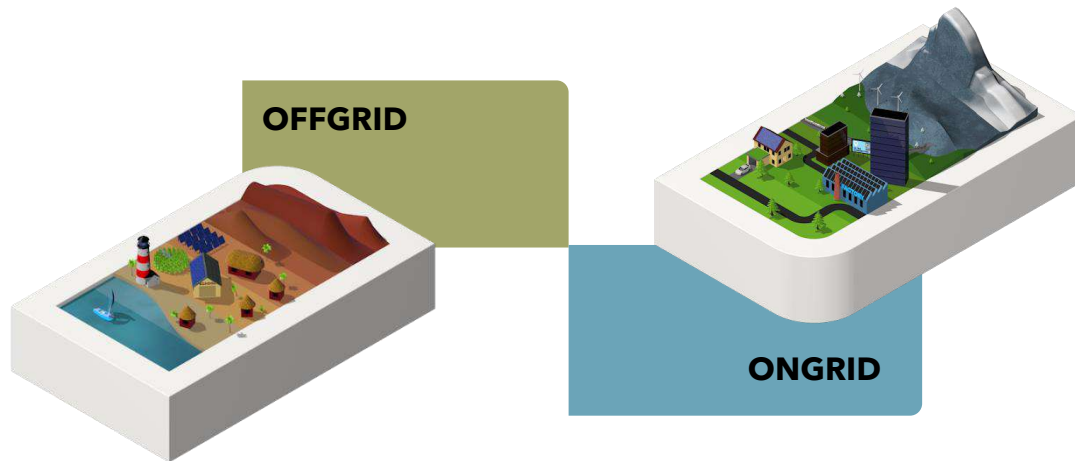

The **next** devices (next1, next1 rack, next3, next3 rack) are high quality converters and are the core of the energy systems. But today energy conversion is not enough: around the power electronics, a whole range of services are necessary: user interface, monitoring, datalogging, remote control, smartphone applications, that is the **nextOS** environment and it is an integral part of the Studer experience. This is documented in this manual.



+

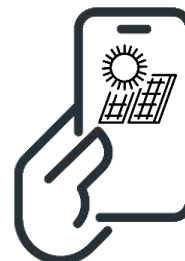

2 General information

2.1 About this manual

This manual contains all the necessary information and procedures to install, configure, use and troubleshoot for the inverters of the **next** range with the help of the nx-interface. Similar interface is available for smartphones and computers through an embedded webserver and is described here.

A summary is provided in the Quick Installation Guide of the nx-interface, delivered with the product in a printed version.

This manual covers the nx-interface and the webinterface that are used with the following devices with software to **1.3.2.0**:

- Hybrid inverter charger **nx3**, with any options, and the integration in **INFRA**.
- Inverter chargers of the range **nx1**.



nx1
inverter charger



nx3
hybrid inverter charger



Infra : integration of nx3
in cabinet with batteries

Refer to the manuals of those devices for details about their installation.

	<p>The latest version of the manuals can be downloaded on Studer website: https://www.studer-innotec.com</p>
---	--

2.1.1 Versions

Rev.	Comment	Rev. date	Reviewer	Author
0.1	First version, forked from nx3 user manual	2023-12-15		mop
0.2	First review in DEV	2024-01-17		mop
0.5	Addition of webinterface	2024-08-10		mop
0.6	Addition of the nx1 related infos	2025-01-15		mop

2.2 Legal provision



The content of this manual is copyrighted by Studer-Innotec SA, Rue des Casernes 57, 1950 Sion, Switzerland

All intellectual property rights in and to the product, including but not limited to patents, copyrights, trademarks, and trade secrets, are owned by the manufacturer or its licensors. The user is granted a limited, non-exclusive license to use the product in accordance with the terms and conditions of this user manual.

2.2.1 Software licenses

The licenses for the installed software can be seen in the dedicated page of the user interface of the product

2.3 Important safety instructions

The nx-interface does not contain any dangerous voltage. It is supplied with isolated 48V by the next1 or nex3 devices.

However,



The next3 and next1 devices contain hazardous voltages in DC and AC. You should carefully read their dedicated user manual. They contain important safety instructions.

Nobody is authorized to proceed with any change, modification, or repair of the equipment without the prior written authorization of Studer Innotec. Use only original parts for any authorized modification or replacement.

2.4 Technical support

Studer-Innotec help its customer the best it can. This is a long time existing service accompanying our products.

Technical support for the product is provided solely at the discretion of the manufacturer. The manufacturer reserves the right to refuse or discontinue technical support for any reason without prior notice.

2.5 Quality and warranty

During the production and assembly of the nx-interface, each unit undergoes several checks and tests which strictly comply with established procedures and device safety requirements. The manufacturing, assembling, and testing of each next1 are entirely carried out in our factory in Sion (CH). The warranty for this equipment depends upon the strict application of the instructions in this manual.

The nx-interface has a ten (10) years warranty (starting from the date of purchase) against material and manufacturing defaults. The defective product will be either repaired or replaced at the discretion of Studer Innotec. A warranty extension is possible with the Studer Care program, giving also other advantages. Warranty conditions are found on our website.

2.5.1 Exclusion of warranty

No warranty claims will be accepted for damages resulting from handling, use or treatment that are not explicitly mentioned in this manual. Damages arising from the following causes are excluded from the warranty:

- Accidental presence of liquids in the equipment or oxidation due to condensation.
- Damage resulting from falls or mechanical shocks.
- Modifications were carried out without the explicit authorization of Studer Innotec.
- Damage due to atmospheric surge voltage (lightning).
- Damage due to inappropriate transportation or packaging.
- Damages due to improper installation
- Disappearance of original identification marks.
- Connection of any cable other than the nx-bus cable on the nx-bus connection and other cables than Ethernet on the Ethernet connection.



Never take off or damage the rating plate showing the serial number. It enables to check and follow-up the data specific to each equipment and is vital for any warranty claim.

2.5.2 Exclusion of liability

The installation, commissioning, use, maintenance, and servicing of the nx-interface cannot be subject of monitoring by Studer Innotec. Therefore, we disclaim all responsibility and liability for damage, costs or losses resulting from an installation that does not comply with the instructions, faulty operation or inadequate maintenance. The use of Studer Innotec equipment is in any case under the responsibility of the customer.

This equipment is neither designed nor guaranteed to supply installations used for vital medical care nor any other critical installation entailing potential risks of important damage to people or to the environment.

We assume no responsibility for the infringement of patent rights or other third parties' rights resulting from the use of the inverter.

Studer Innotec reserves the right to make any modifications to the product without prior notification.

Studer Innotec is not liable for incidental, direct or indirect damage of any kind, including any profit loss, revenue loss or damages caused to equipment or goods due to defective equipment.

2.6 Conventions

2.6.1 Glossary

AC: Alternative Current

AC-Load: The AC-Load is a physical connection for the electrical loads. It is separated from the grid in case of grid failure and backed up by the inverter. The connection is 3 phases and neutral. Single phase load can be connected.

AC-Flex: The AC-Flex is a physical connection for 3 phases and neutral. It can be configured for a use as a secondary AC source, or for a use as a controlled secondary AC load.

AC-Transfer: with "transfer" we mean the fact that the AC-Source is connected to the AC-Loads with the internal relays of the next1. The input voltage is "transferred" to the output.







PE: Protective Earth

Solid neutral: when the AC-Source and the AC-Loads neutral are physically connected with a bridging cable.

Transfer: have a transfer means be connected to the AC-source with the internal relay. The inverter switch to a current source mode.

Multi-unit system: a system with several next1 or next3 units running in parallel and synchronized with the communication cable.

2.6.2 Symbols and conventions

	This symbol is used to indicate safety instructions, which, if not followed, could result in a risk of electrical shock with possible serious personal injury or death to the operator or the user.
	This symbol is used to indicate a risk of material damage and/or the cancellation of the guarantee.
	This symbol is used to indicate a procedure or function that is important for a safe and correct use of the equipment. Failure to respect these instructions may lead to the cancellation of the guarantee or to a non-compliant installation.
	This symbol placed on the product indicates that its surfaces may reach temperatures higher than 60°C.
	This symbol placed on the product indicates that its use must follow the instructions in the user manual.
	PE= protective earth (connected to the enclosure of the device).
	For information specific to the Australian model of the nx3 to be compliant with the standards AS/NZS 4777.2. This is used for the New Zealand as well.

3 HMI: Use of nx-interface

The end-user can interact with the next3/next1 with different interfaces: the remote control nx-interface, with webapp on smartphone, on the web monitoring portal and with the APP on a smartphone/tablet. These are the HMIs (Human Machine Interface) available. It is also possible to communicate with the next3/next1 with machine to machine via communications through Web API to the portal and MODBUS RTU or TCP.

This chapter describes the use of the nx-interface. This device is a local interface connected to the next with a communication/power cable and allows to:

- **Visualize** the state of the next3/1 system, present and past values, including the log of the events that happened to the system.
- **Configure** the devices: The next3/1 configuration can be modified by the installer/user at commissioning to adapt the equipment to the energy system in the best possible way. The normal process to configure the next3/1 is the use of the "Configuration Wizard" at the commissioning. This is a step-by-step procedure that helps you to configure the system in a simple way. This avoid mistakes and is the preferred way to configure the device. Individual settings are also accessible for each part of the next3/1. The factory values of these settings are reported in the table at the end of this manual.
- **Record monitoring data:** In order to analyze what happened in the energy system, the nx-interface stores measurements data in its internal memory and on a USB memory stick for later analysis (csv files).
- **Be connected:** The nx-interface is also the gateway to the outside world. It allows to connect a system to the internet and the Studer monitoring portal. If the nx-interface is connected to the internet, the recorded data can be sent to the Studer web portal user account(<https://portal.studer-innotec.com>). The nx-interface is also the gateway to MODBUS communication with third party control systems.

A user level system allows the installer to manage the access rights and the complexity of what is shown to the end user, from "View Only" to "Expert" with the right to modify any settings.

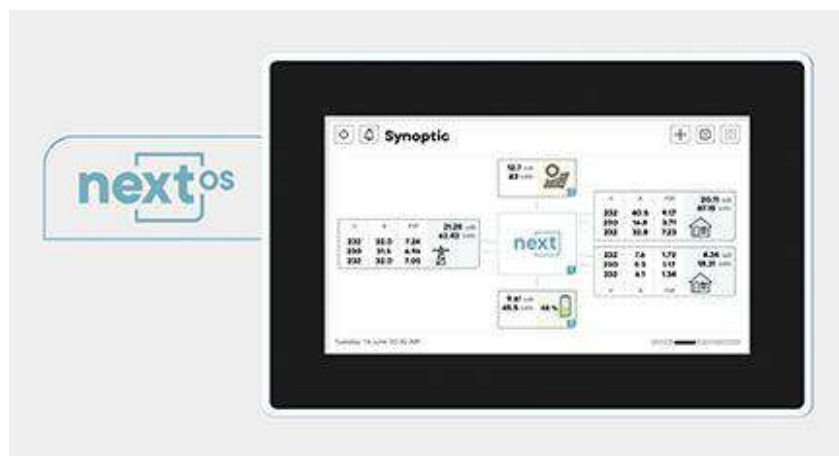

3.1 General navigation and use

The nx-interface a touch screen display. The navigation from one page to another is done by pointing/clicking on an element. The main icons used for navigation are:



	Access to main menu. This icon is on every screen and click on it to come back to the top level and navigate quickly
	Access to settings (level3). There are prepared graphical screens for setting and an access to the whole list of settings with the + symbol from there in EXPERT mode.
	Access to detailed lists of information (from info screen) or list of settings (from settings screen). The + is accessible only in EXPERT MODE for list access.
	ON/OFF of all the functions of the inverter. A confirmation is asked
	Back on the previous screen in the menu hierarchy
	Enable or mute the beeping of the remote and the inverters.
	Page indicator: you can swipe left/right to move to different pages of the same level. For example, when there are many solar chargers in the system, you can navigate from one to another.

Example for the information screen of solar:

Back on upper level (here the synoptic view)

Access to solar list of info

Access to solar settings

Main menu

Swipe to other MPP inputs (here are 20 inputs)

3.1.1 Screens map

The navigation on the nx-interface is organized as given by the picture below. A locked screen appears after some time of inactivity on the nx-interface. It is unlocked with a slide move or with a code. From the locked screen you go back to the last screen that was displayed before entering sleep mode.

The main menu is always accessible from any screens with the icon: available on each screen.

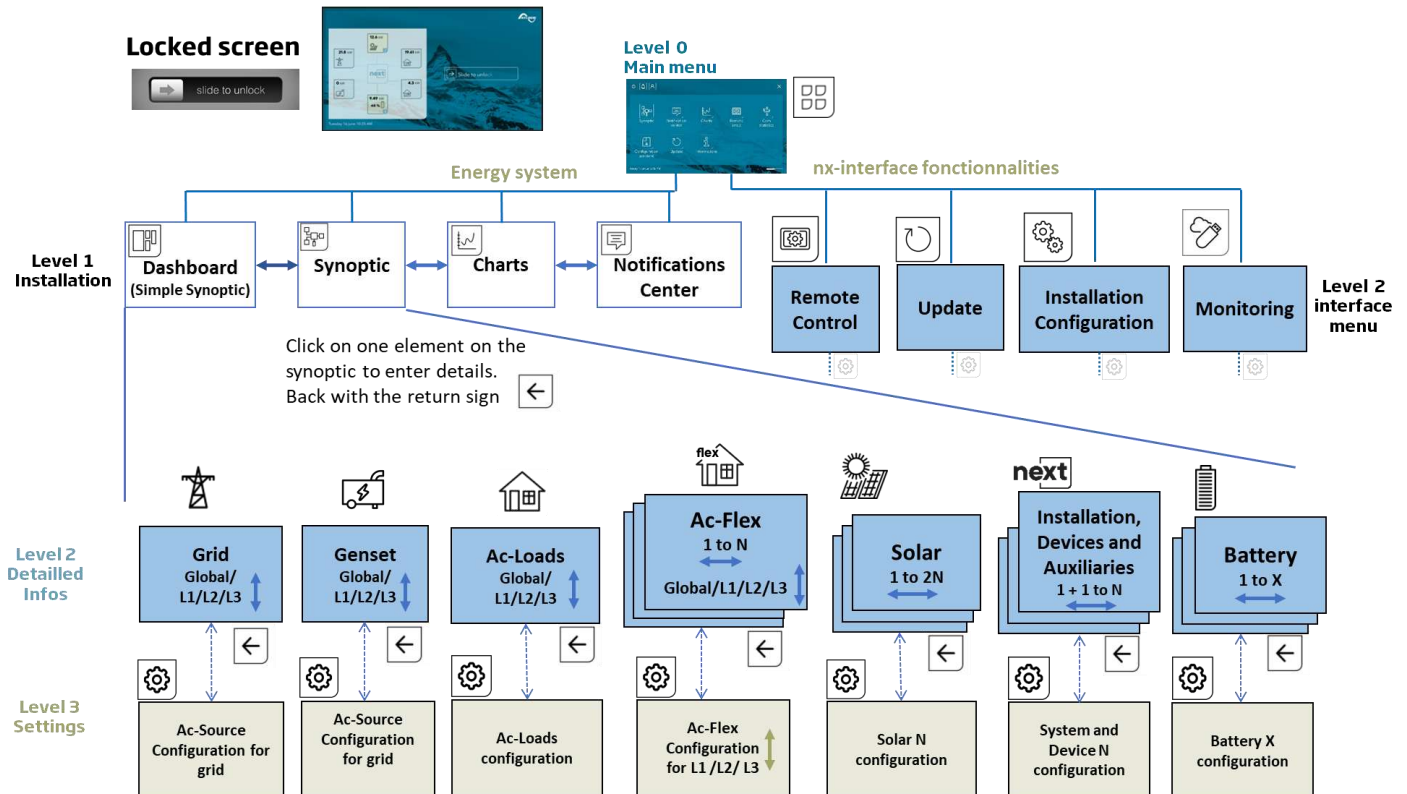

The nx-interface screen is organized with screen levels:

- **LEVEL1:** general view of the state of the energy system, the instant values, the history, and the message log.
- **LEVEL2:** Information about each component (AC-source, Battery, solar,...) Many detailed information that can be obtained from the next3/1 about the inverters operation. For example the AC-reactive power of the phase 2 on the AC-source connection can be seen by going on the AC-source from the main synoptic.
- **LEVEL3:** Programming: the settings about each component can be seen or modified.

Note: when on a configuration screen (Level 3), the settings are for a unique component. Per exemple there are two solar mppt entries on one next, the settings are accessed individually.

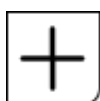

For convenience and simplicity, not all information can fit on one screen. From the level 2, the "plus" button allows to access a list of detailed information. From the level 3, the "plus" button allows to access a list of detailed settings.

The "plus" of level 2 and 3 is accessible at expert level only. The unique reference identification number are used in communication and to clearly identify the information/settings.

Navigation is done from the dashboard or from the synoptics to the detailed information and settings of physical elements.

The following chapters gove details about each component of the energy system (the solar, the AC-source, the AC-Flex, the battery, ...).

Example with the battery:

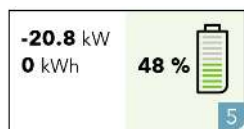
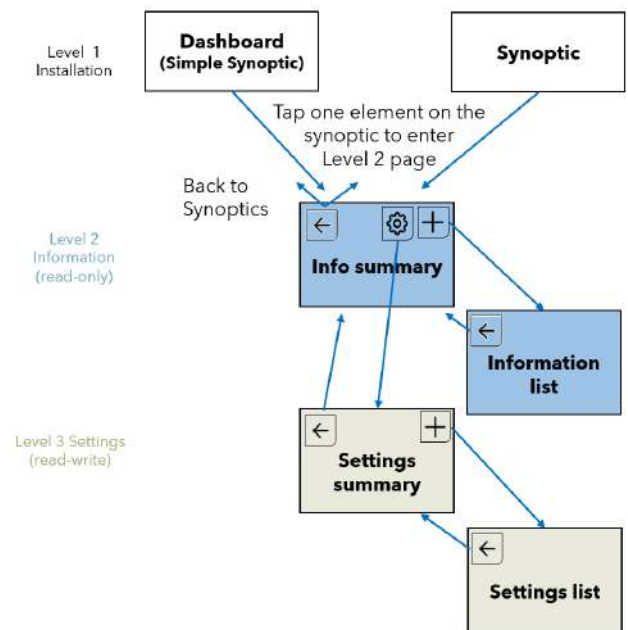

Dashboard or Synoptic (level 1)
A few general information about the battery

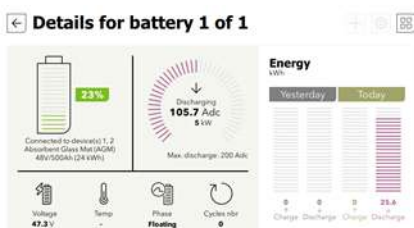

Visualize details (level 2)
Information screen is always with the inversed T screen organization. Bar-graph of today and yesterday energies for comparison on the right side of the screen.

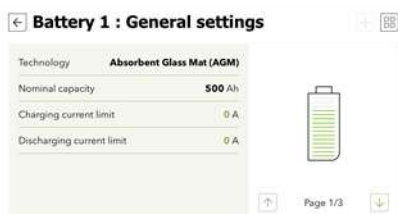

List of all possible information with expert access right with the sign



Basic Settings (level 3) access with Image on the right and selected



Advanced settings:
access to the full list with expert access right with the sign

3.1.2 Embedded documentation

The nx-interface has an embedded documentation about all information (level 2) and settings (level 3) available.

- Access to documentation about one setting/information by clicking on its name
- Change the settings by clicking on its value

Settings for MPPT for PV field 1 of 4

Enable MPPT converter

Algorithm: **Least square fit**

Check for global MPP

Period for global MPP check: **3600 s**

PV U-I-P curve

Click on name:
Go to documentation about the setting

Click on value:
Modify the setting value

Algorithm
ID 10.1.25.0
Used to select the MPPT algorithm.
The choices are:
- Least square fit: Improved version of the well-known perturb and observe algorithm.
- Fixed voltage: Allows the user to set manually the converter voltage setpoint.
- Fixed open-circuit voltage ratio: Allows the user to set manually a ratio between the converter voltage setpoint and the open-circuit voltage. The converter returns periodically at

The documentation/explanation about the received messages are also embedded by clicking on one message.

Notifications center

Severity	Category	Message
Info	Next3.1	Status for solar 2: Night
Info	Next3.1	Status for solar 1: Night
Info	Next3.2	Status for solar 2: Production
Info	Next3.2	Status for solar 1: Production
Info	Next3.1	Status for solar 2: Production
Info	Next3.1	Status for solar 1: Production
Info	nx gateway 1	Webportal connection status for gateway webp...
Info	Next3.2	Status for solar 2: Night



Info
23-09-8 00:00:00
nx gateway 1 - gateway webportal
Webportal connection status (ID 20.1.22.0)
Connected: Webportal is connected and paired with the installation.

The full list of information and settings with their default values, units, ranges, and explanations can be found in the Object Model description document. That is an appendix available for MODBUS communication. Each parameter/setting/information has its own unique identification number starting with the prefix ID. The same documentation is embedded in the nx-interface.

3.1.3 Accessibility

User accessibility: can be changed in the nx-interface menu with user levels.

The levels are:

- **View Only:** the user has access to levels 1 and 2 of the screens (dashboard, synoptic, graph, messages, view of components information). The configuration icon  is not accessible and the user cannot change anything in the configuration of the system. Code is 00000.
- **Basic:** the user has accessed to the level 2 and 3 It is possible to modify the configuration of the next without the full list of settings (the full list icon  is not accessible). The important settings for the standard operation of the next system are available on the prepared screens of level 3. Code is 815566.
- **Expert:** the user has accessed to all information and settings. Access is restricted for end-user as the grid code settings must be chosen by the qualified installer at commissioning and modifications are not allowed. The expert code is delivered only to qualified installers.

On the first commissioning the nx-interface is set to Expert to allows the use of the wizard process and then automatically set down to View Only.

The modification of the user level is done with codes in the nx-interface, in the remote control screen and then on the configuration menu



The codes are beside:

View Only:	000000
Basic	815566
Expert	For professionals only

Remote control





3.1.3.1 Blocking access with customized code

The slider of the locked screen can be replaced by a code to unlock. This prevents the modification of the system by unwanted people.



The activation of this code is done in the remote control screen and then on the configuration

menu ( → ). It is available for experts only.

The unlock code can be freely chosen.

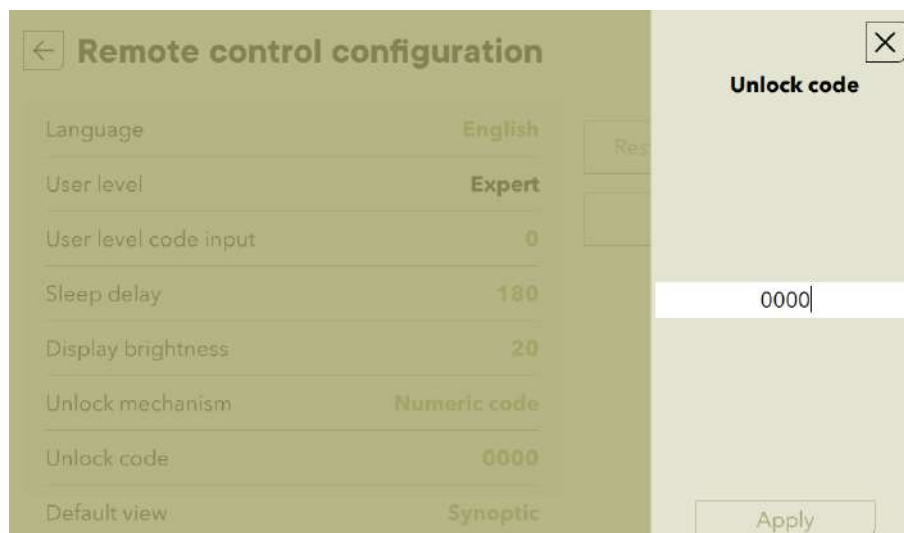

3.2 Displaying the state of the energy system on the nx-interface

The actual and historical state of the energy system can be seen on the screens of Level 1 of the energy system.

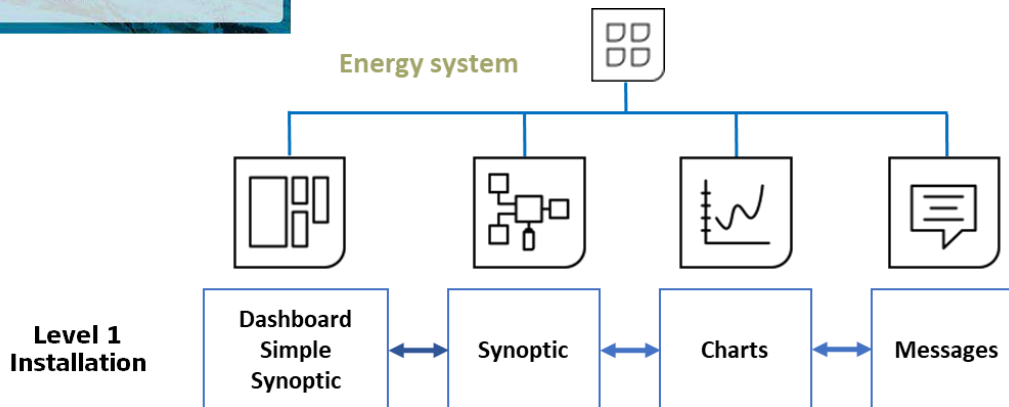
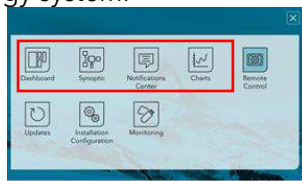

The status of the energy system is seen with two screens the simplified dashboard of the synoptic

3.2.1 Simple dashboard

Power fluxes and state of the battery can be seen. In one blink you know what your production is, consumption and general state of the system. All powers are the sum of all devices and all phases. The same general overview is on the "locked screen".

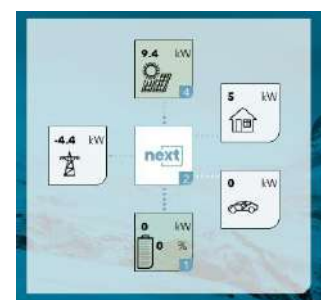
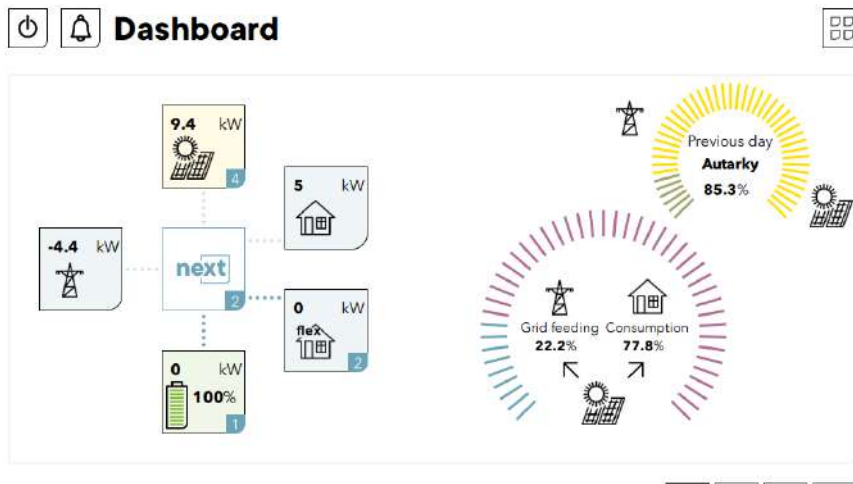

The displayed pie chart are:

- The **autarky rate** (or self-sufficiency rate) is the part of the consumption coming from solar or storage.
- The second graph is the **self-consumption rate**: it indicates where the solar production goes: in the house, to load or storage, or injected back to the grid.

When one element is not existing in the system, it is simply not displayed. Per example the screen of the nx1 without solar:

🔌 🔔 **Tableau de bord**

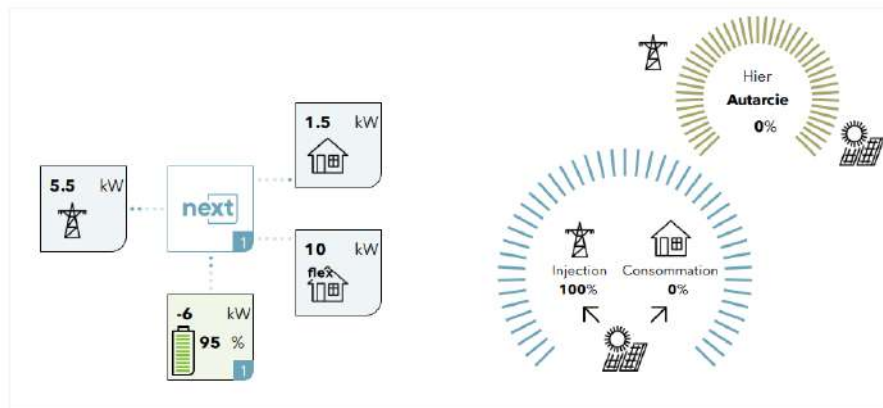

Jeudi 9-01-2025 11:55 🌤️ 🔄 🗑️



3.2.2 Synoptic

The detailed synoptic gives access to the information and the programming of the various components (click on it):

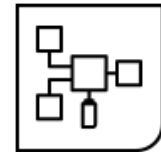

- **AC-Source:** the AC-grid or a genset. There is only one AC-source connection in a system.
- **AC-Loads:** the consumers: there is only one AC-loads in a system.
- **AC-Flex:** A special entry that can be configured as
 - A second source, there is only one second source connection in a system. The AC-source has priority of connection over the AC-flex as second source.
 - A controllable load, in that case there are as many AC-Flex as loads than the number of nx device in the system.
- **Battery:** there can be many in a system.
- **Solar:** the solar PV strings (for nx3 only), and/or the solar chargers (with the Variostring or variotrack connected through xcom485).
- **Device and I/O (AUX contacts, Remote Entries, COMM ports, ...):** on every nx device of a system.

From the dashboard or the synoptic, the details of each component are accessed by clicking on it. See the general screens map in previous chapter for an overview of the navigation.

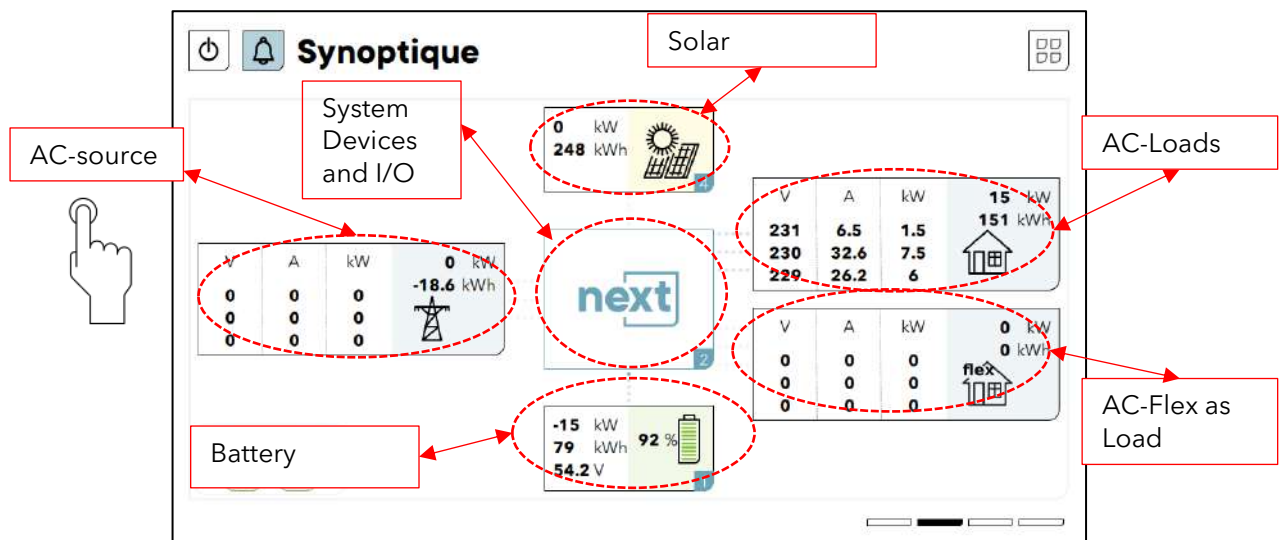

Note that the AC-source as genset and the AC-flex as genset are missing on the figure above as we cannot display all the different configurations on the same screen.

An important alert on one of the components can be seen with a change of colour. It is associated with a warning or error and with a message explaining what happens.

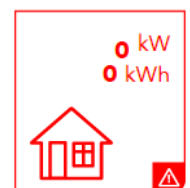



Detailed maps of levels 2 (information) and 3 (configuration) for the energy system:

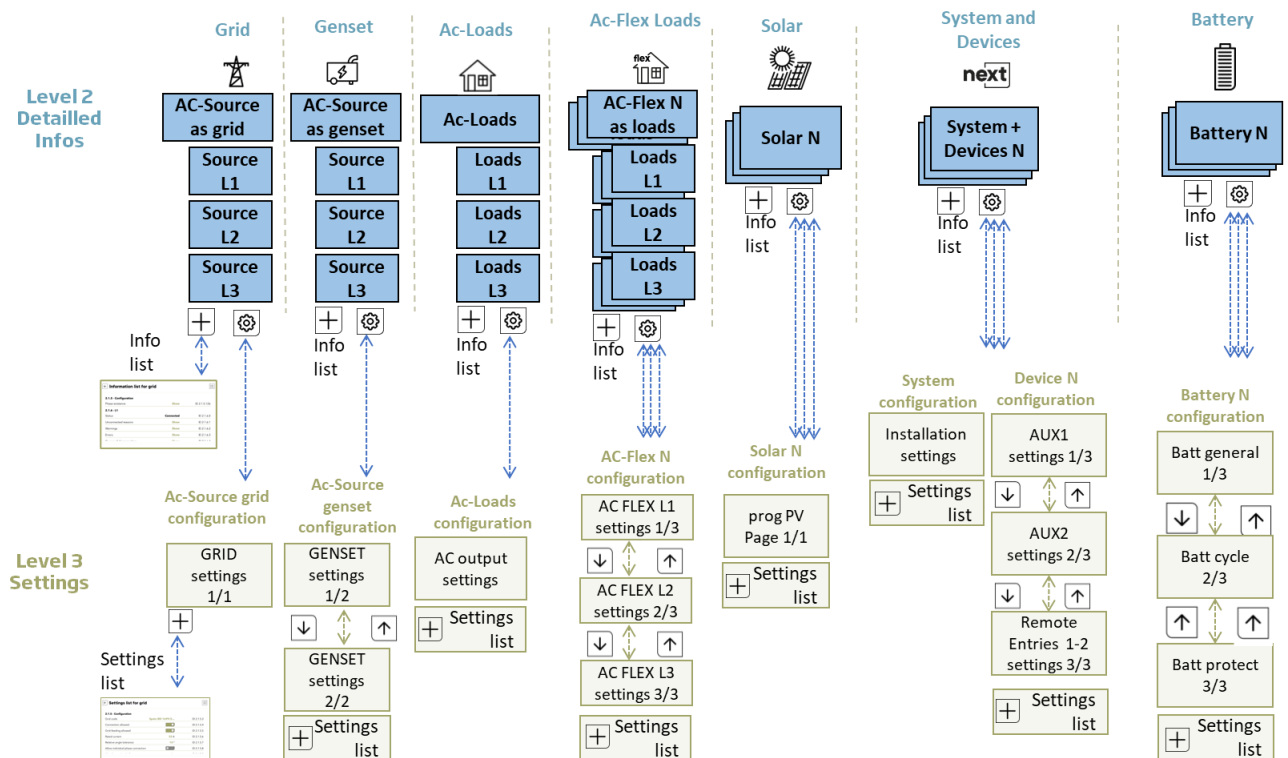

3.2.3 Simple chart

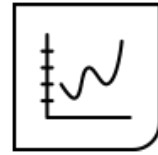

The energies of yesterday (00:00 to 23:59) and today (00:00 to now) are shown in a bar graph.



TO COME: Power and battery charts will appear with future updates.

3.2.4 Messages



List of messages/ events that happened to the system.

The errors and warnings are in red when they appear and in green when they are cleared.
It is possible to filter the message in function of their severity:

- **Information:** a normal event happened in the system and is logged.
- **Warning:** something abnormal happens and the next3/1 operation can be restricted but the device is not stopped.
- **Error:** an event that stops the operation of one of the component of the next3/1 or the whole next3/1 happened.

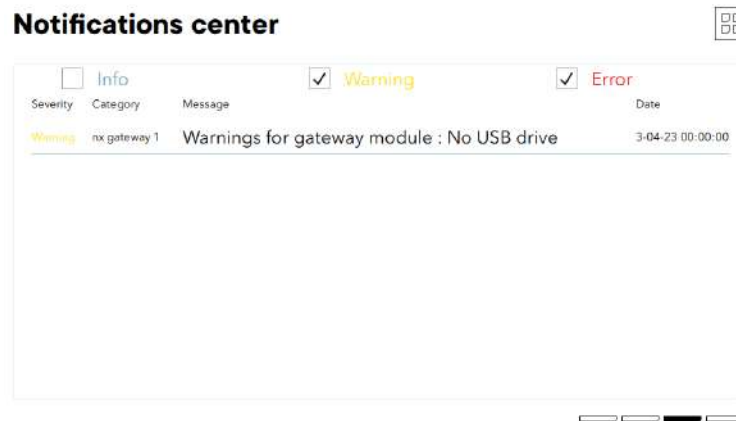

3.3 The nx-interface functionalities

The nx-control has 4 dedicated menus for settings and actions specific to the interface:

- **Remote control:** manage the nx-interface itself (user access, language, brightness of the screen,...)
- **Updates:** update of the whole system is done with the nx-interface with by copying the new firmware on the usb key or with internet download of the new software.
- **Configuration of the installation:** start a new configuration wizard here.
- **Monitoring and internet:** configure internet connection and connection to the Studer webportal and manage the datalog on the usb-key. The Modbus M2M communication for monitoring by external SCADA system is also managed here.

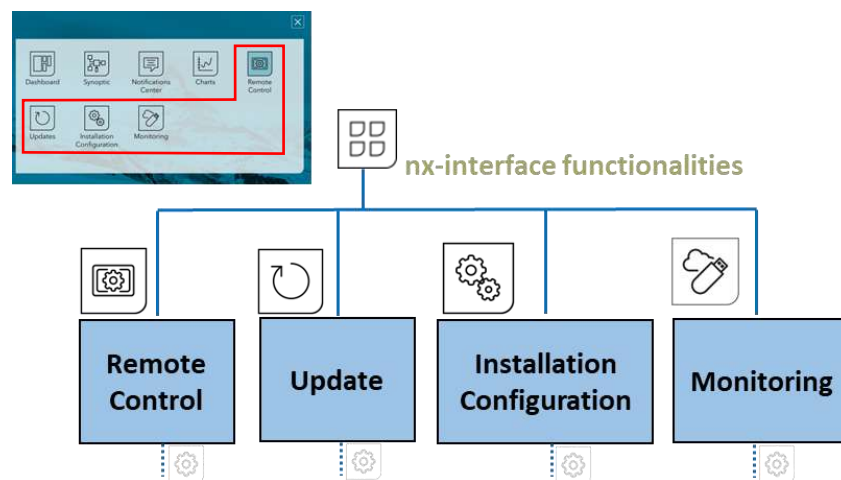

3.3.1 Remote Control



This menu is for the nx-interface itself (Language, user level, brightness of the screen, ...).

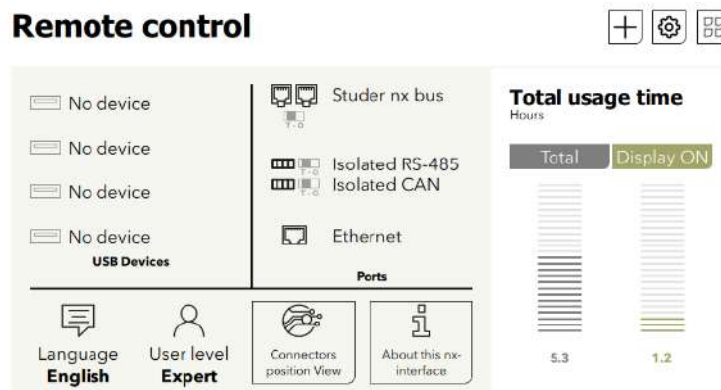

Most notable options available in the settings (with ) are:

- The language: English, French, German, Italian, Spanish
- The access level: This menu give access to the user levels. The codes are:
 - View Only: 000000
 - Basic : 815566
 - **Expert** : For professionals only
- The sleep screen and the accessibility: with slider or protection code

The connectors view helps to locate the connectors on the side (usb) and under the nx-interface. The physical connections are a little bit hidden under the nx-interface and this is very useful to find them:

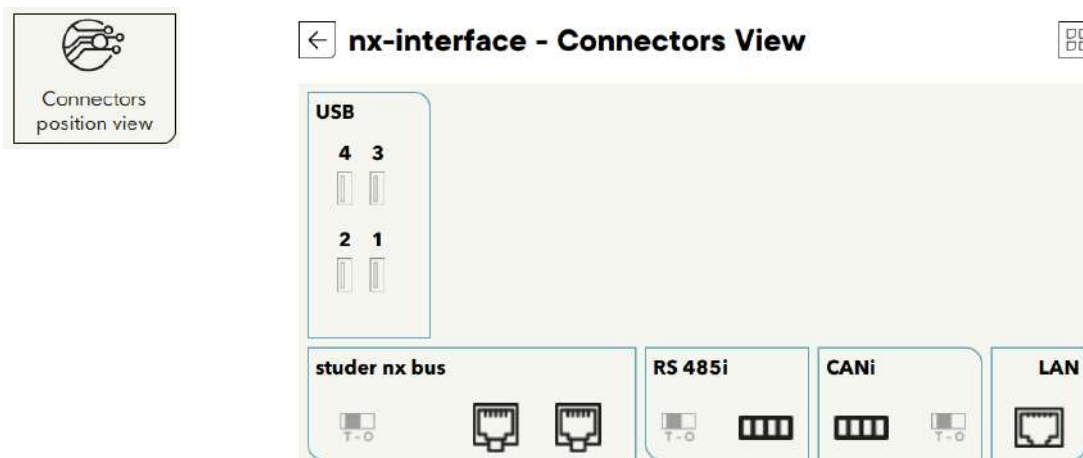

3.3.1.1 USB memory stick management

Hot Plug of USB memory is possible. Always remove the USB using the EJECT button on the nx-interface. The eject button is available in different menus and has the same effect.

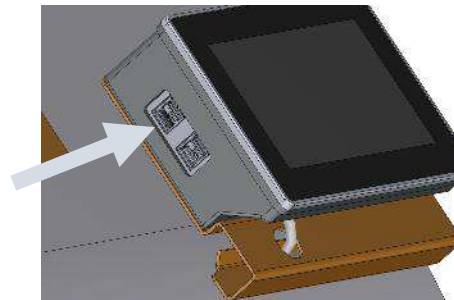
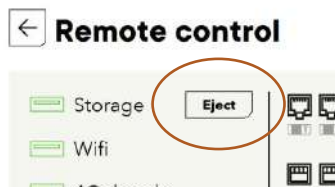

The USB-stick is also used for

- Datalogging backup
 - Procedure: see the monitoring section
- Update of the systems.
 - Procedure: see the update section
- Manual savings of the configuration and files (to come)
 - Procedure: see the configuration section



With the code version 1.3.0 of the nx-interface, only one USB key per system is managed. If a USB is already plugged in and you want to plug another key, remove it first.

3.3.2 Update

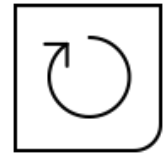

This part describes the update of the next system (inverters, nx interface and accessories) using the nx-interface.

The internet connection and recent versions of the next3/1 allow for an easier update of the system. Systems with old versions or without internet connection require the use of the USB stick. First determine in which case you are:

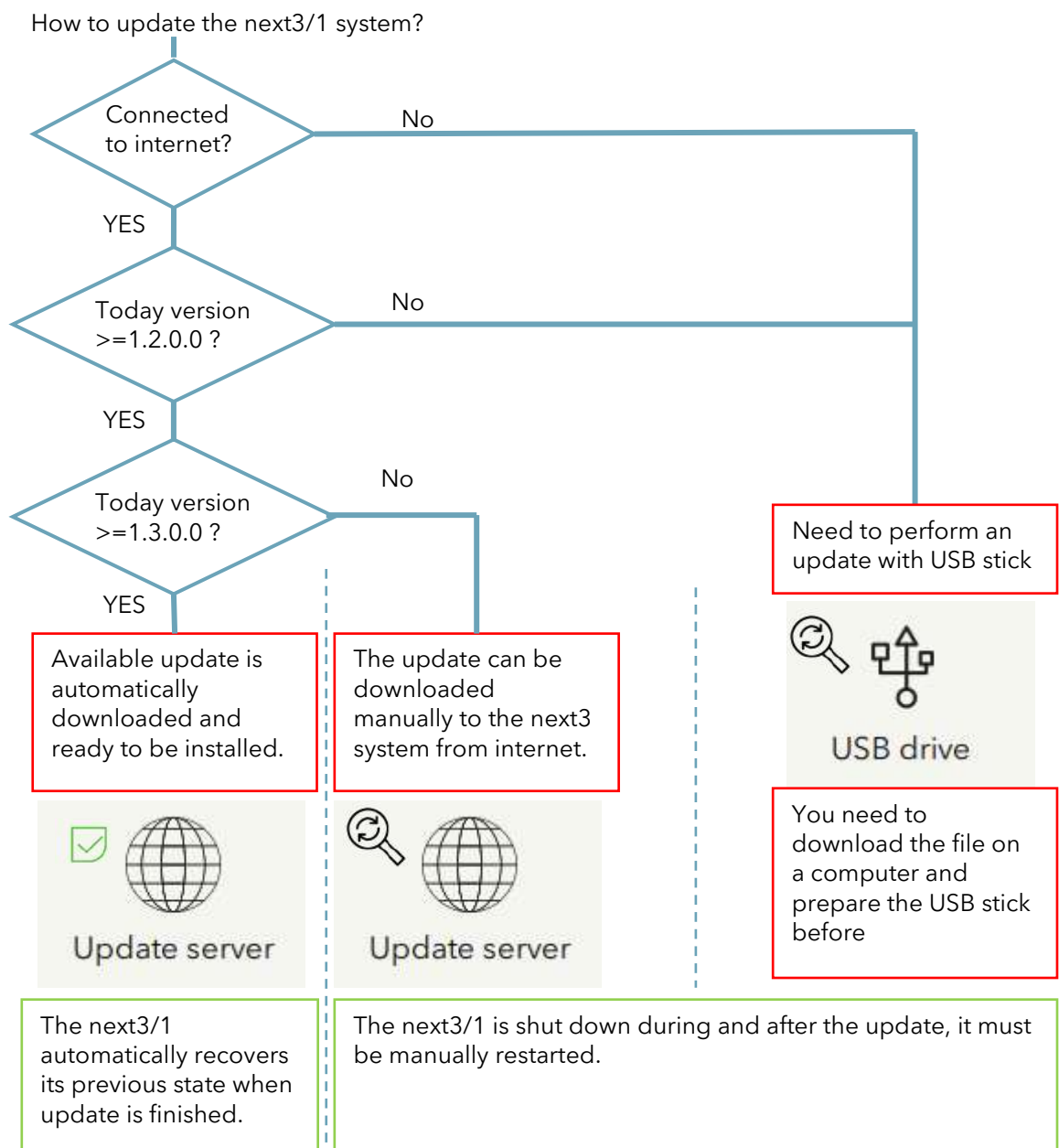

If you need to prepare the USB key in advance:

- Download the latest software version from our website: <https://www.studer-innotec.com/en/downloads/> in the support and download section.
- Unzip and copy the whole folder called "next3-system-update" or "next1-system-update" at the root of the key.
- Make sure that the copy process is finalized before removing the USB from the computer.
- We advise to eject the USB properly to avoid any file corruption issue.

On the update page:



The current version (in black) and the available updates (in green) can be seen on the right side. Information will be displayed in case of software incompatibility.

For the 3 cases described above:

- Automatic update download (from version 1.3.0.0)
If an update is available, simply click the "start update" button.
The check for new update is done once a week. If you are informed that there is a new version available before the automatic search, it is always possible to click the search button to check the update server at that time.
- Non-automatic update download (from version 1.2.0.0)
Click the search update button and then when the update is available, click the, "start update" button.
- USB key update (older versions or without internet)
Insert the USB key in the nx-interface. There must be only one USB stick in the nx-interface. If there was already one, you should eject it before.
If there is no update automatically available, you can click "Search USB" to confirm if the update file is on the USB unit. When an available update appears in green, click the "start update" button.

The USB-key must not be removed until the end of the updating process. If for some reason the updating process is interrupted, restart it to let the process finish.

The USB key presence is mandatory even for the internet update, as the files are copied on the USB key. Always keep the provided USB key on the nx-interface

During and after the update

You will see a message to inform that the system will restart during the update procedure. Please be aware that the next3 will turn off and on during the update process.

In older version, the update is performed in many steps: first the nx-interface is updated and then you must press again on the "start update" button again for the next3 devices. After version 1.1.0.0 all updates are performed automatically one after another.

If you update from version 1.3.0.0 or later to a higher version. The next3 will recover its initial state, that means the inverter will restart automatically if it was ON before launching the update. In any case there is a short interruption of the powersupply to the AC-loads. It will be OFF after update if it was already stopped before the update.

Before version 1.3.0.0, the next3 is always stopped for the update and a manual start with the front button (2 seconds), or the "ON/OFF" button in the next interface.

Note: The usb key must not be removed until the end of the updating process. If for some reason the updating process is interrupted, please restart it, and make sure to let the process finish.



The updating process can take between 3 and 15 minutes. NEVER disconnect the battery during an update. During this process, the installation is stopped, and the AC power supply is interrupted. Choose the proper moment to process an update.



When multiple elements are connected to the nx-interface I and to the next3 by the communication bus, it is possible that the software versions are not compatible. It is highly recommended to update the software of all components in the system to guarantee all functionalities.

Therefore, before starting the setup of the device, download the latest software version from our website: www.studer-innotec.com on an USB key. Follow the instructions in this manual for a successful installation.

3.3.3 Installation Configuration

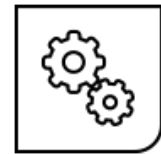

In those pages you can reconfigure the next energy system from the start with the wizard. The configuration pages are available **at expert level only**.

A summary of the system is available on the main screen and a list of all present devices of the system is situated on the left.

+ [Grid Icon]



Installation en fonctionnement

...



Start wizard

Summary

2x next devices
 230V 230V 230V 50Hz
 Grid: Grid code Belgium
 Genset: L1/L2/L3
 2x AC-Flex as FlexLoads
 1x 48V battery
 Country: Angola

Device	Status
nx interface (this device) S/N : NEXT_RC_0001	OK
nx3 16000-48 st S/N : NXT_3PH_012345	OK
nx3 16000-48 st S/N : NXT_3PH_123456	OK

For a factory setting reset, you must run the wizard again. It will reset all the values with the factory values according to your configuration. All the settings previously set are forgotten when running a new wizard.

3.3.3.1 Wizard

The standard configuration of the next3 energy system is done with a configuration wizard. It is possible to modify single settings individually later the pages dedicated to each topic of the converter (AC, battery, solar, ...).

On the first commissioning of the next3, the wizard will be automatically started, and all steps must be followed. To restart with factory settings, you must run the wizard again on an installation.



The wizard is automatically launched on the first commissioning of the next3. At the end of the wizard process, the nx-interface is set back to the basic level. This is necessary to avoid the change of critical settings later by end customer (grid codes).
To access the wizard, you need the expert level code.

The wizard is a list of questions that the installer must answer to configure the energy system itself. The full list of questions and comments are done in a dedicated section of this manual: "Configuration and operation of the next" and then in the "Initial configuration with the Wizard".

If you stopped in the middle of the process or the installation has changed, there will be an error message:

nextOS manual v0.7 | 3B5N

2025 © Studer Innotec SA | 31



Unlock the screen and finish or restart the wizard process in that case.

3.3.4 Monitoring & datalogging



Today, monitoring a renewable energy system is essential. The Studer monitoring provides continuous information (real-time and past behaviour) for a deep understanding of the operation of the system. Having the right information at hand facilitates the follow-up of the performance as well as remote diagnostics and problem anticipation.

There are three kinds of monitoring and control in the Studer environment:

- **Local monitoring and control:** this is done with the nx interface or local webapp. The daily storage of data is done on the USB key as a backup. At any moment all the data can be retrieved on the USB key and analyzed locally on a computer, even in remote area without internet.
- **Remote monitoring and control** via Internet is possible with two options:
 - for professionals and advanced users - Studer Portal is a web site with multiple functionalities (visualization, graphs, email alerts, download of data, ...). Connect your nx-interface to the internet to get all the advantages of the Studer Portal available here: <https://portal.studer-innotec.com>.
 - for end-users - Studer Easy Monitoring App is a simple and intuitive way to see the status of the system and its history. It is available in IOs and Android. The Easy Monitoring APP uses the webportal as backend and accounts must be created on the portal to use the APP.
- **Own monitoring:** the user can develop its own monitoring and control of a next system with the use of MODBUS communication. Modbus RTU and TCP are supported. RTU with RS485 connection and TCP with the Ethernet connections, both situated on the nx-interface or directly available on the next1.

On the nx-interface all settings necessary for the monitoring are managed in the Monitoring menus. On the main screen, the state of the different aspects of monitoring can be checked quickly:

- Is there a USB key and space left for datalogging on it?
 - Eject to take the key away to copy data on a computer
- Is internet connected?
 - View the connection status and setup the Wi-Fi connexion
- Is the studer webportal connected and operational?
 - Set up the pairing with the portal with the GUID number.
- Modbus
 - Enable Modbus communication with TCP or RTU (disabled by default)

Monitoring



Status:

USB key	No drive	Eject
Internet connection	Disconnected	Config
Webportal	Connected	Config
Datalog sync.	Unknown	
Modbus	Off	Config

Save datalog
(last 7 days)

Manage datalog

Web interface
(BETA)

Memory usage
Used/total memory GiB

Internal	USB
[Progress bar]	[Progress bar]



The status of monitoring is also seen with the logos at the bottom of each screen, here with portal connected and no usb key:

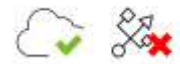

3.3.4.1 Local monitoring: Datalogging in internal memory and on usb-key

A record of all electrical values is done in nx-interface but also in the next3 devices themselves. In all cases, the usb key on nx-interface is the way to take the data out of the system.

The USB memory is used for a periodical backup of monitoring data. A daily .csv files is copied automatically as soon as an USB memory stick is plugged on the nx-interface and has sufficient storage space left. The daily files contain all the data recorded with 1min/1hour/1day/1month rate, and the day notifications.

There is no limit for the USB key capacity, however the USB key must have a valid FAT32 partition where the data will be saved.

For a 32 GB partition on USB key, and same installation as described hereabove, the partition can hold more than 10 years of data. When the USB key is full, a message is shown on the nx-interface.

The internal memory of the next3 is limited and stores the data for a limited timeframe. The quantity of log data that can be stored in a next3 device depends on the type of next3 device (-s, -t, -st, ...). Here is an indication of the data that can be stored in the next3:

- 1min data: at least the last 3.5 days of data (nx3 with full options), up to the last 50 days (nx3 inverter only).
- 1hour data: at least the last 50 days of data, up to the last 3 years
- 1day data: at least the last year of data, up to the last 15 years
- 1month data: at least the last 26 years of data
- List of notifications: 130'000 last notifications (~15 years if 1 notification/hour)

In the nx-interface, the quantity of data that can be stored depends on several factors:

- Installation configuration, number of devices
- Other data saved in nx-interface internal memory, e.g. datalog from previously connected installations.

Here is an indication of the data that can be stored in the nx-interface, assuming there is only one installation datalog in internal memory, and this installation has only one next3 device:

- 1min data: last 200 days of data
- 1hour data: last 6 years of data
- 1day data: at least the last 10 years of data
- 1month data: at least the last 10 years of data
- List of notifications: at least the last 10 years of data

The memory for each type of data is managed with a first-in first-out strategy: when the memory is full, the oldest data are overwritten.

If a new USB key is plugged in the nx-interface, it is possible export the monitoring data recorded internally. This is performed in the "manage datalog" app.

As the transfer can take a long time, the menu allows you to choose what is transferred.

← Datalog data manager



In this page, you can import datalog data from your next Devices to this nx-interface.
Note that only available data will be imported.

Last	0	hours of minutes data	Import minutes (duration ~0 minutes)
Last	0	days of hours data	Import hours (duration ~0 minutes)
Last	0	days of days data	Import days (duration ~0 minutes)
Last	0	months of months data	Import months (duration ~0 minutes)
Last	0	days of Notifications	Import Notifications (duration ~0 minutes)

Monday 1-02-2021 10:43

When removing the USB storage, always wait for the end of the data transfer and use the "eject" button for a proper end of operation.

3.3.4.2 Set up of the internet connection

The connection can be done with

- A connection with an LAN cable as described in the wiring chapter. If Internet is available at your router, there is no special configuration to do.
- An Wi-Fi connection that can be selected in the second page of the internet connection configuration. Scan the available Wi-Fi, select one and enter your password.

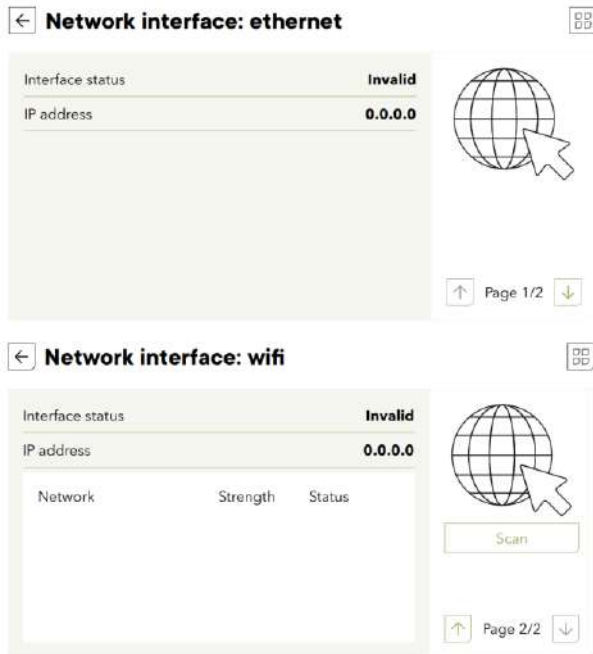

The Wi-Fi connection requires the USB Wi-Fi stick provided by Studer. Don't use any other stick as there are drivers necessary and there is a high probability that it will not work.

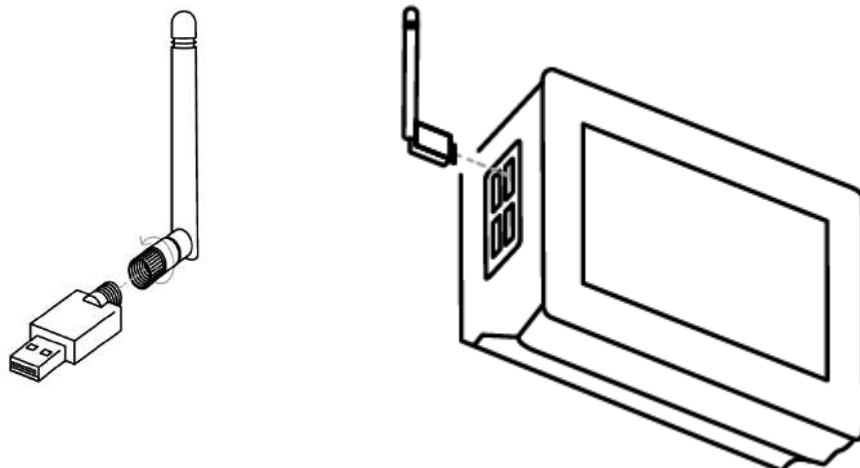

3.3.4.3 Remote Monitoring with Studer Web Portal (Internet)

The remote monitoring is done via the Studer Monitoring Portal: <https://portal.studer-innotec.com>

To connect an installation on the web portal, you'll need a to perform a pairing, which means you have to identify an installation and make the link to your portal account. This is done with a unique identification number called GUID that is entered on both side of the communication channel: in the next3 and in the web portal:

← **Webportal configuration** 



In this page, you can configure the GUID, used to communicate with the Studer Webportal. The current GUID value is :

NAATUCF22E6JMUI2IXJLZ2NYKREMTI4R

Generate new GUID on this nx-interface :

Automatically get new GUID from Webportal :

Manually enter new GUID :

Enter information about the installation

Name

Name

Type d'installation

xtender NeXT

Guid

NAATUCF22E6JMUI2IXJLZ2NYKREMTI4R

Never give the same GUID two times to two different installations. In case of doubt, use the automatic GUID generation

If a proper GUID is entered, the webportal info will be "connected and paired".
When all the csv files are transferred to the webportal, the datalog synch info will be "synchronised".

3.3.4.4 SCADA monitoring: MODBUS

The user can develop its own monitoring and control of a next system with the use of MODBUS communication. Modbus RTU and TCP are supported. RTU with RS485 connection and TCP with the Ethernet connections, both situated on the nx-interface.

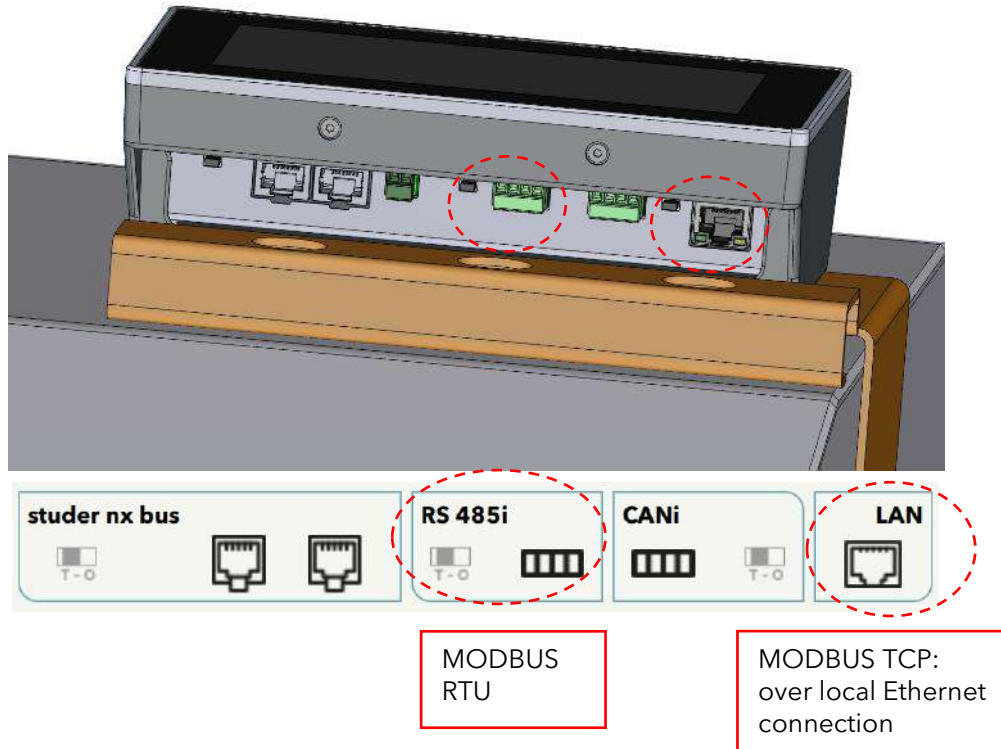

Only one Modbus mode at a time can be used. It is not possible to use RTU and TCP at the same time. This is selected with the "Modbus mode"

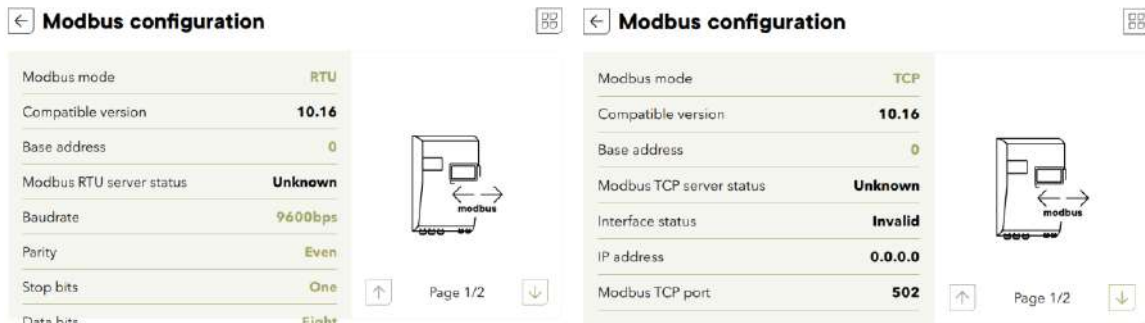

For security reasons, the Modbus is deactivated by default and there is a specific user level for the Modbus communication to limit the access through this channel. Per example use the View only to block all changes and accept only read requests. It is located on the second page of the Modbus menu:

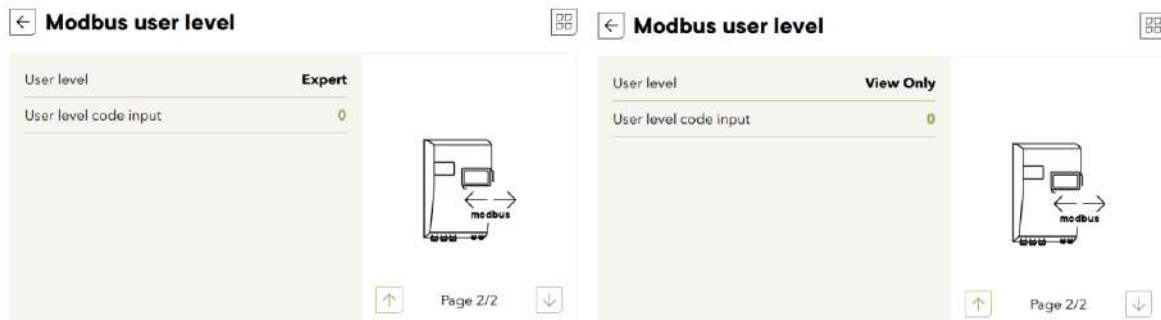

The Modbus specification with the registers list is given in a dedicated document for developers.¹
Code examples is available on Studer GitHub: <https://github.com/studer-innotec/next-modbus>

¹ On Studer website, <https://technext3.studer-innotec.com/modbus-next>

4 HMI: Local web interface via webserver

The functionalities of the nx-interface are reproduced in an embedded webserver. This allows you to display and control the system on a web browser (computer, tablet PC or smartphone). This is the default HMI available for the next1 as the communication board is by default embedded in the device and there is no nx-interface delivered with the product (available as an option).

The design, structure, list of settings of the webinterface is similar to the one on the nx-interface. Please see the chapter about the nx-interface above, for the structure of the menu, navigation, and functionalities.

The webinterface is available on:

- nx-interface
- gateway embedded in nx1

The webserver is available to at the address <https://studer.local> in the local network with different modes: .

- with a direct **Ethernet connection**:
 - Connect the nx-interface or the nx1 with a network cable to your router.
 - If your device (smartphone, PC, ...) is on the same local network, you can access the webinterface in a browser
- **Access Point Wi-Fi** connection:
 - If there is no internet installed, the device itself creates its own Wi-Fi where the user has to connect (what is called an web access point or hotspot). That is the default mode of the next1 (Factory configuration).
 - You must connect your device (smartphone, PC, ...) to this wifi access point, then you can access the webinterface in a browser
- Through a configured the Wi-Fi connection (**Wi-Fi client** mode) :
 - Once you have configured your gateway's internet connection (on the nx interface touchscreen or with webinterface in access point) you can connect to your private Wi-Fi network. If your device (smartphone, PC, ...) is on the same local network, you can access the webinterface in a browser.

If you want to use the Wi-Fi connection, the nx WIFI dongle accessory must be plugged, with antenna mounted:

- nx3+nx-interface : nx WIFI dongle USB stick with antenna must be plugged in a USB port
- nx1: nx WIFI dongle is embedded in device. The antenna must be screwed on the nx1 after the wall mounting to avoid damaging it.

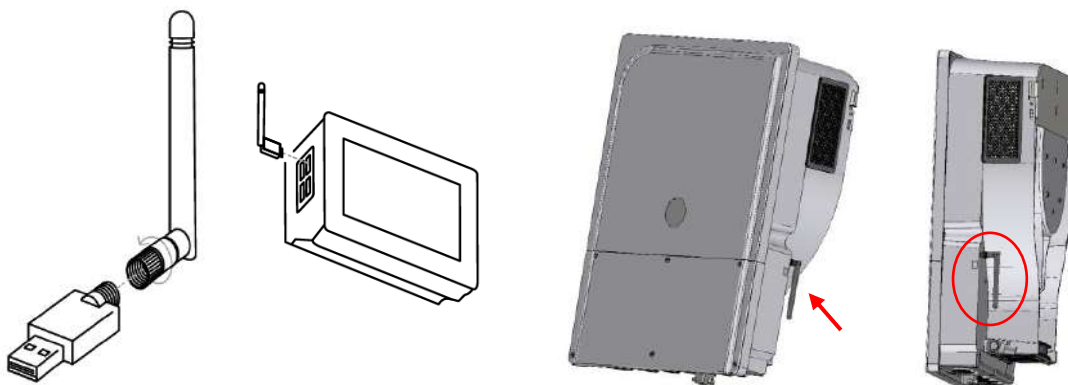

4.1 First commissioning with web access point (nx1)

As the nx1 is delivered without nx-interface (available in option), its default mode is to have the Wi-Fi in hotspot and the first commissioning is done with web interface. The commissioning of nx3 is performed with the nx-interface.

The general commissioning process is:

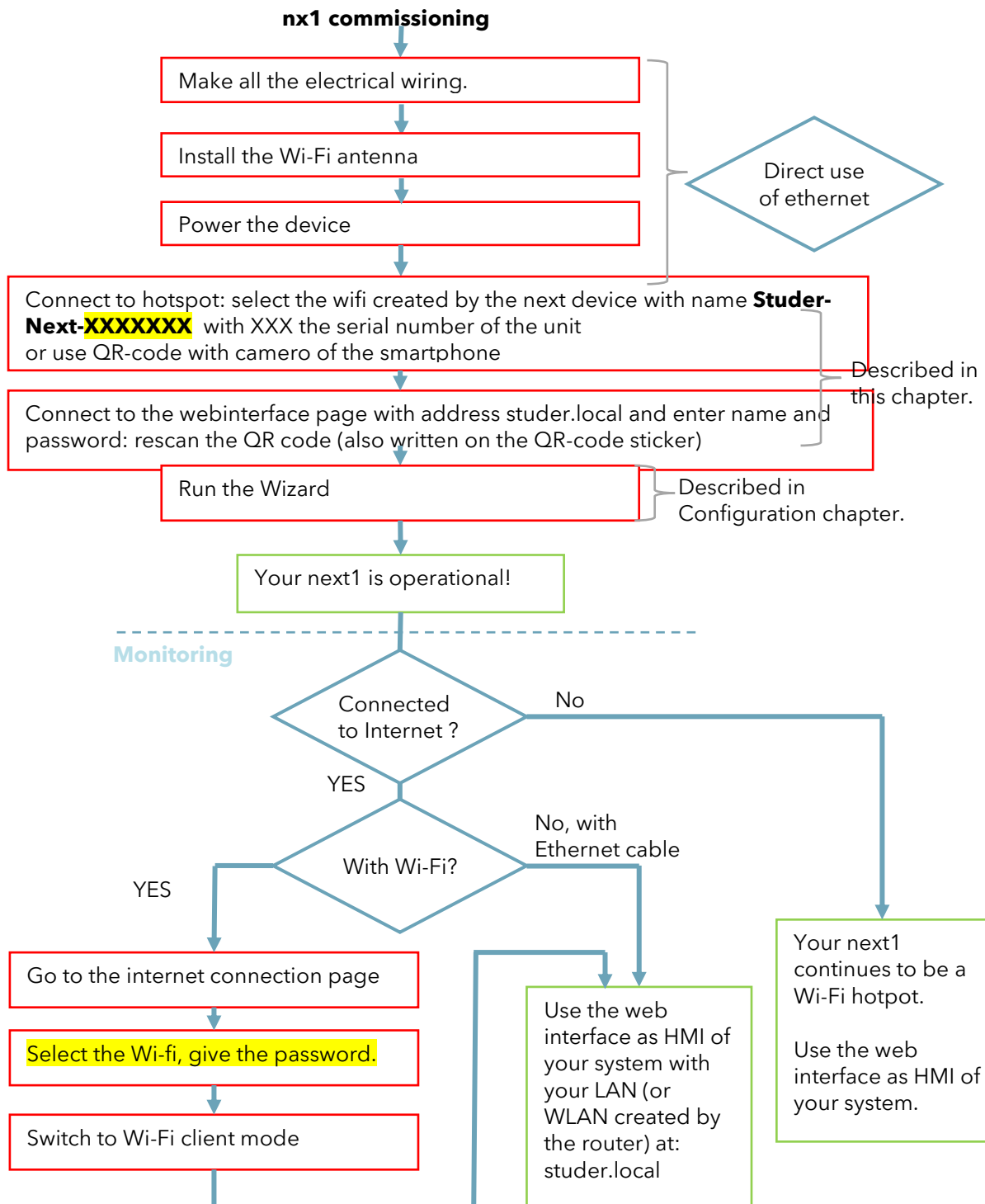

How to connect with the nx1 hotspot:

1. **Check that the Wi-Fi antenna is in place and the device powered.**
2. **Look for the proper Wi-Fi on your computer or your smartphone:**
 - a. **The Wi-Fi is named **Studer-Next-XXXXXX** with serial number of the device.**
3. **Once the connection is established, open a browser and type the address <https://studer.local> or the **IP address 192.168.1.100 (default in webaccess point)****
4. **If nothing comes in, please check the DNS troubleshooting section below.**
- 5.

Option with QR code

1. **Check that the Wi-Fi antenna is in place and the device powered.**
2. **Look for the QR code sticker on the side of the nx1**
3. **Scan the QR code using your smartphone's camera or a QR code reader app.**
4. **If your smartphone has this feature, you will be prompted to connect to the Wi-Fi hotspot. Once the connection is established, open a browser and type the address <https://studer.local>**
5. **If nothing comes in, please check the DNS troubleshooting section below.**

Once the connection is established.

For the nx1, if you lost your credential for connection, you can always reset the system with a physical button to turn back to the hotspot mode.

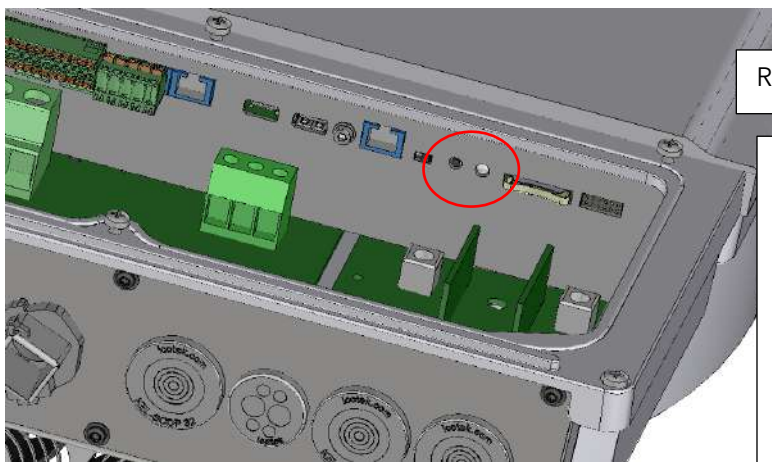

Reset button: **3 seconds push**

Info LED:

- **Blue:**
 - **blinks in hotspot mode?**
 - **Permanent light if connected on an wi-Fi as client**
- **Blink 2x ...**
- **Red:**
- **Green:**



AC ELECTRICITY INSIDE THE DEVICE: DANGER OF DEATH

When the next1 is under operation, it generates voltages that can be potentially lethal. Stop the AC of the unit before opening the cover. Battery voltage must be present to power the electronic.

4.2 Access with the nx-interface

The use of this functionality with the nx-interface is simple as the nx-interface screen allows to display information. The management of the webserver interface is done in the monitoring menu:

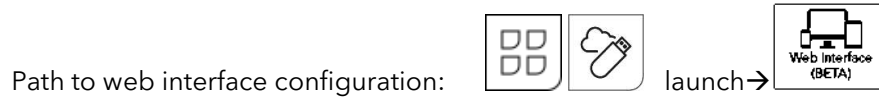

The username and password are available on the dedicated nx-interface screen. The direct IP address is available and this can be used directly if the alias URL studer.local is not handled properly by the router:

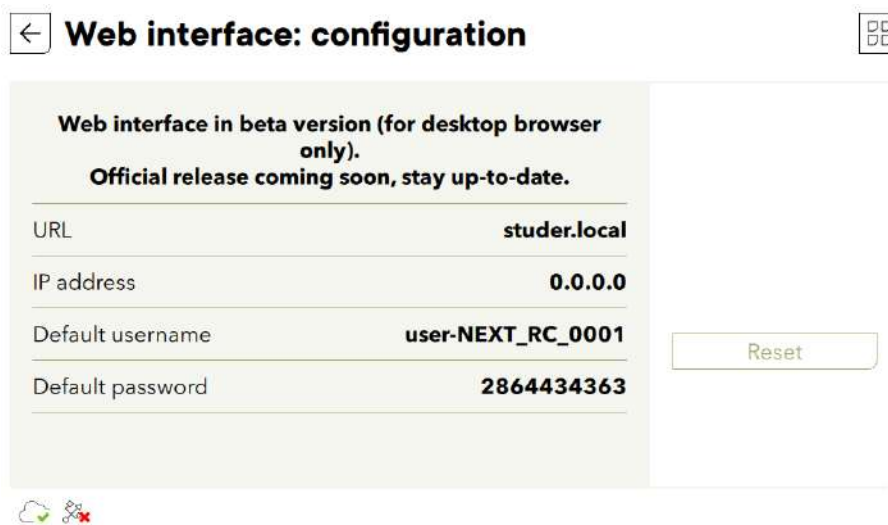

The default configuration of the nx-interface is:

- Wi-Fi is in client mode
- Webinterface is activated. **(note: possible de désactiver? Par défaut ? → NON pas possible, protégé par pwd qui est pas générique)**

To turn the nx-interface to a Wi-Fi access point, you can use the reset button on the webinterface page. This is similar to the physical reset button in the nx1. It allows to restart in hotspot:

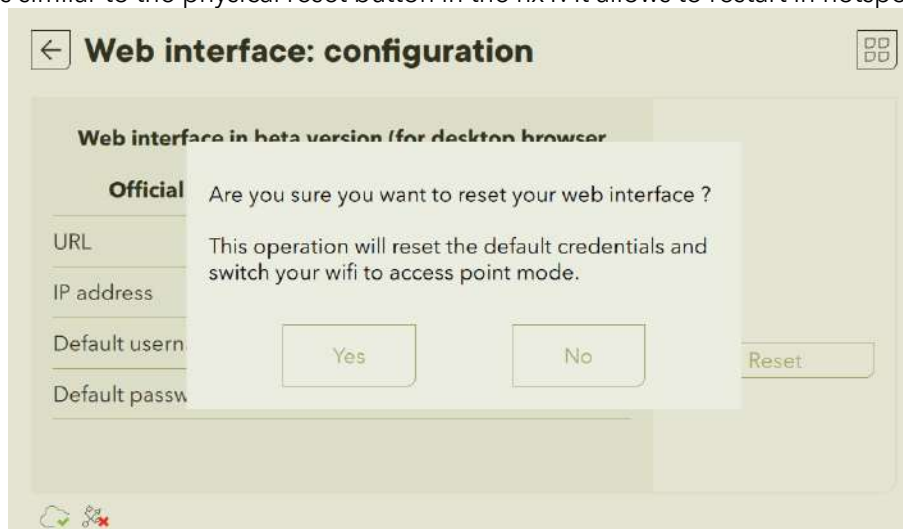

Or in the internet connection, Wi-Fi page:

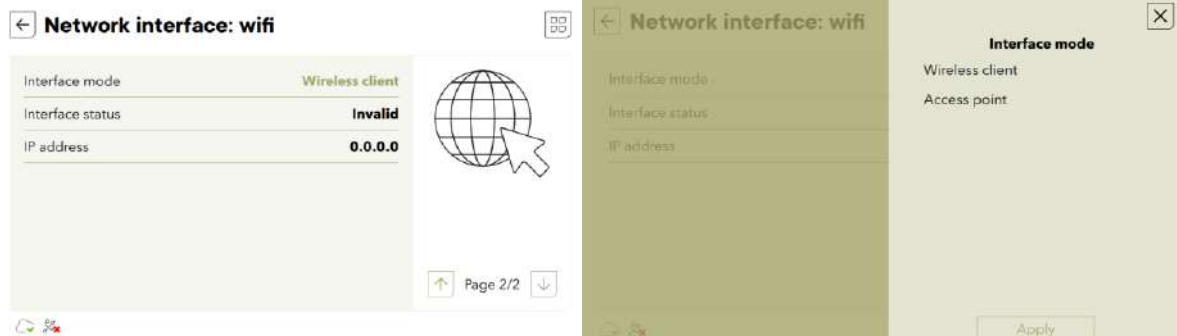

Note that you'll lose your standard Internet connection and portal monitoring if you are in hotspot mode.

4.3 Use of the web interface

the web interface is available at address <https://studer.local/> when the user is situated in the same LAN or WLAN as the next3/1 system.

A login is necessary to access the device for cybersecurity reasons.



For the next1 the default user is written on the label on the side of the unit.

- Username: **user-XXXXXX with XXXXX the serial number**
- Default password: **TODO**

Please change the default user password after the first connection for security reasons.

The username and password are available on the dedicated nx-interface screen when using the web interface through this way:

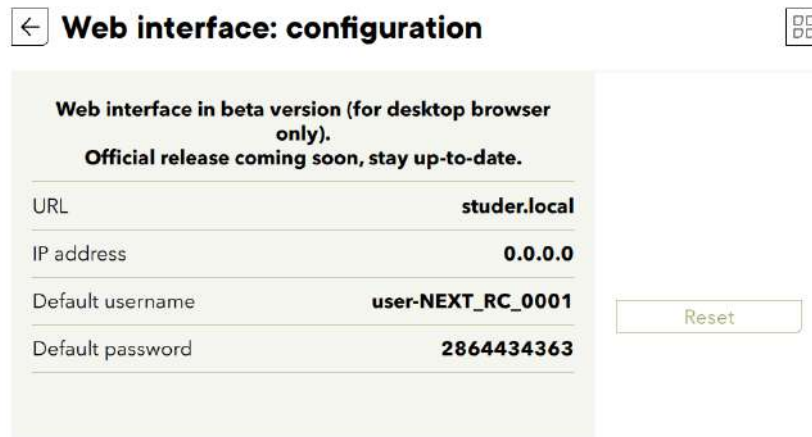

The design and structure of this way to interact with the next1/3 is like the one on the nx-interface, please see the chapter about the nx-interface above, for the structure of the menu and functionalities.

4.4 DNS troubleshooting: “page not found”

Some internet routers do not accept the alias URL address `https://studer.local` to communicate with a local device². The real IP address should be used instead. To find it on the nx-interface is easy with the screen.

For the nx1 the following steps can be tried to solve the problem:

- If the problem is encountered on the hotspot/access point Wifi network, use the default IP address: 192.168.100.1
- Find the direct address on the portal: if the installation could connect to internet with an LAN connection or Wi-Fi , then there is a way to read the information of the IP address on the monitoring portal with the properties accessible in the control page:
 - ID 20.1.18.4 for ethernet IP
 - ID 20.1.19.4 for Wi-Fi IP
- Try multiple times, some devices only try once.
- Use an IP scanner tool
- Verify that the DHCP server settings on the router are correctly configured. This information is usually available in the router's web interface. Ensure that the DNS server addresses are accurate and reachable. Find the next1 IP address there.

For the nx3, it is possible to see on the nx-interface with the screen:

² mDNS is used to replace the IP with a fixed and easier address given as an alias in letters. This is a widely used practice and most routers or computers are compatible. But that cannot be guaranteed.

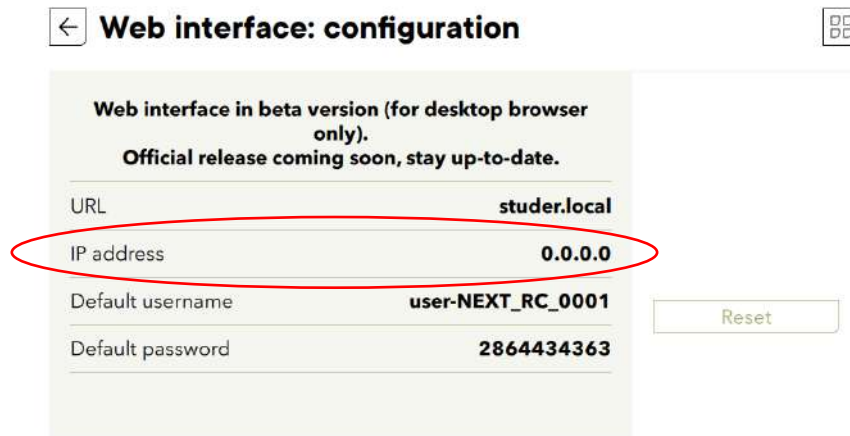

4.5 Limitations of the embedded webserver

At the **software version 1.3.2.0** the embedded webserver is not fully equal to a nx-interface with screen:

- Are different:
 - The screens of the details of each element (level 2) and settings of each elements(level 3) are not available.
 - The access to all properties is done with simplified version (similar to the one on the portal).

More features will come progressively with future updates...

4.6 Use of webinterface as private remote monitoring

It is possible to use the webinterface as a private secure remote monitoring with a VPN channel.

5 Configuration and operation of the energy system

This chapter of the manual explains how to configure and operate the next3/1 with the nx-interface for each functionality of the next3/1 inverter. See the chapter about the nx-interface for its general use.

5.1 Essentials to know about a next3 and next1 systems

The next3 is a hybrid inverter-charger with 2 solar MPPTs. It can work in a stand-alone (offgrid) mode or connected to an external AC source, being a grid or a generator.

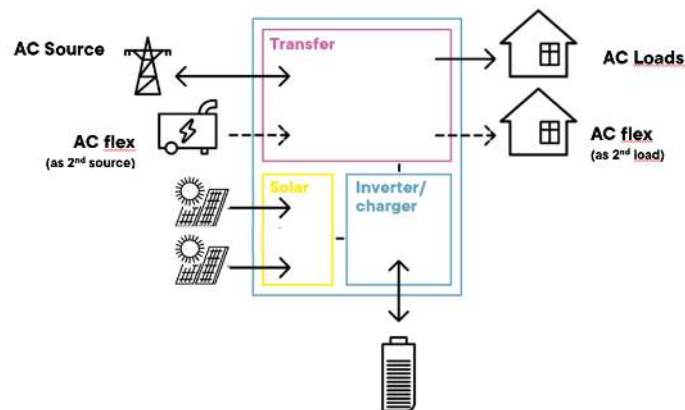

The next1 is an inverter-charger that can work on and offgrid. Except the solar part, it has the same functionality as the next3. When it is combined with a compatible external solar charger (Variotrack/Variostring), the management of solar is done the same way as in the nx3.

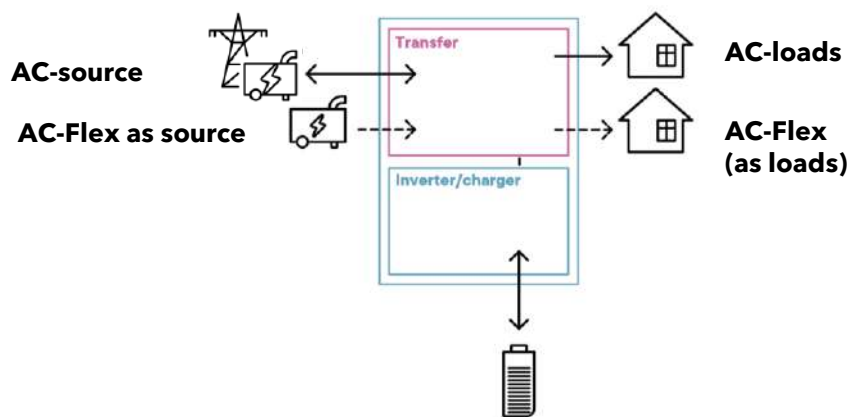

A few concepts must be understood to use and configure the next3/1 systems properly:

- The next3 and next1 have a connection named **"AC-Source"** where comes the main AC source: the grid or a generator.
 - This input has a high security level, with doubled security relays for disconnection according to new international grid code and safety standards (for example: IEC 62109, VDE-AR-N 4105, EN 50549-1, ...). In case of connection to a distribution grid, always connect the grid to AC-Source.
 - The choice to use AC-source to connect to the grid or to a genset is done during the first configuration of the system. It cannot be change 'live', while the system is working, and would need a complete reset of the system if you want to change it. The behaviour of the nx is different with a grid or with a genset.
 - The grid code choice must be set properly by the qualified installer during

commissioning according to the local requirements of the DSO (Distribution System Operator). This is done during the wizard process. It can only be changed with a complete reset of the system and restart of the wizard process. The access code "Expert" that enable access to the wizard after the first commissioning is not public for this reason.

- AC-source works with three-phased grid only if a grid code is selected because (all) grid codes ask to have the proper 3 phases for 3-phased systems. Operation on a single phase is not allowed. Operation on a single phase is possible if a genset is selected as source during the wizard.
- There is only one connection to one AC-source in a system even in a multi-unit system when there are physically multiple connections.
 - Transfers are never used in parallel and only one transfer switch will be operated. That means the max transfer current is 80A for next3 even with 3 next3 in parallel.
 - The identification of which AC input is used in multi-system is done during the wizard configuration process.
- The next3/1 is an "offline UPS", that means the AC main is supplied directly to the load with the internal transfer switch (no double conversion). This implicate that the voltage and frequency of the grid is the same on the loads side.
- The maximal current/power taken from the AC-Source can be controlled in order to cope with limited connection (per example max amps of the grid connection). The next3/1 can compensate with battery power with the Smart-Boost function.
- On the other side, it has a connection named "**AC-Loads**" where the load/consumption is connected, that are supplied by the batteries/solar when there is no grid or genset.
 - There is only one AC-load in a system: in multi-units all the AC-loads output must be electrically connected. All next3/1 work together to create a single voltage (distribution panel).
- The choice to operate "**AC-FLEX**" as a connection for an second voltage source, like a genset as source, or for controllable loads is done at first configuration and cannot be changed during operation (like for the AC Source).
 - Similar to the AC-source, there can only be one AC-Flex as source used in a system.
 - In case it is used as source, the priority can be chosen with a system setting: first one valid that comes in, AC-source or AC-flex.
 - In multi-unit systems the AC-flex connections must not be wired in parallel. The programming of the AC-flex as load are independent for each next3/1 (slide left and right on the screen to access each individually). The programming is done for each phase L1, L2 and L3 independently. That means for a multi-unit system with 3 next3, there can be up to 9 single phase controllable loads used.

5.1.1 Understand the General Energy Strategy

The next3 and next1 are renewable energy friendly converters and always try to optimize the solar in the system. The energy management between all the converters and components of the energy system is done by the *Power Flow Dispatcher* algorithm. This is at the core of the next system.

Studer simplified the use of its product to be transparent to most of the end-user. Four standard energy strategies are available and can be selected during the configuration process in the wizard with only two questions to answer:

- is grid feeding allowed? This question is asked only if you have selected "grid" as connection to AC-source. If you selected "genset", the grid feeding is forbidden.
- Is battery used for solar self-consumption optimization? That means the battery is used daily as an energy buffer. Solar energy recharges the battery and is used during the night.

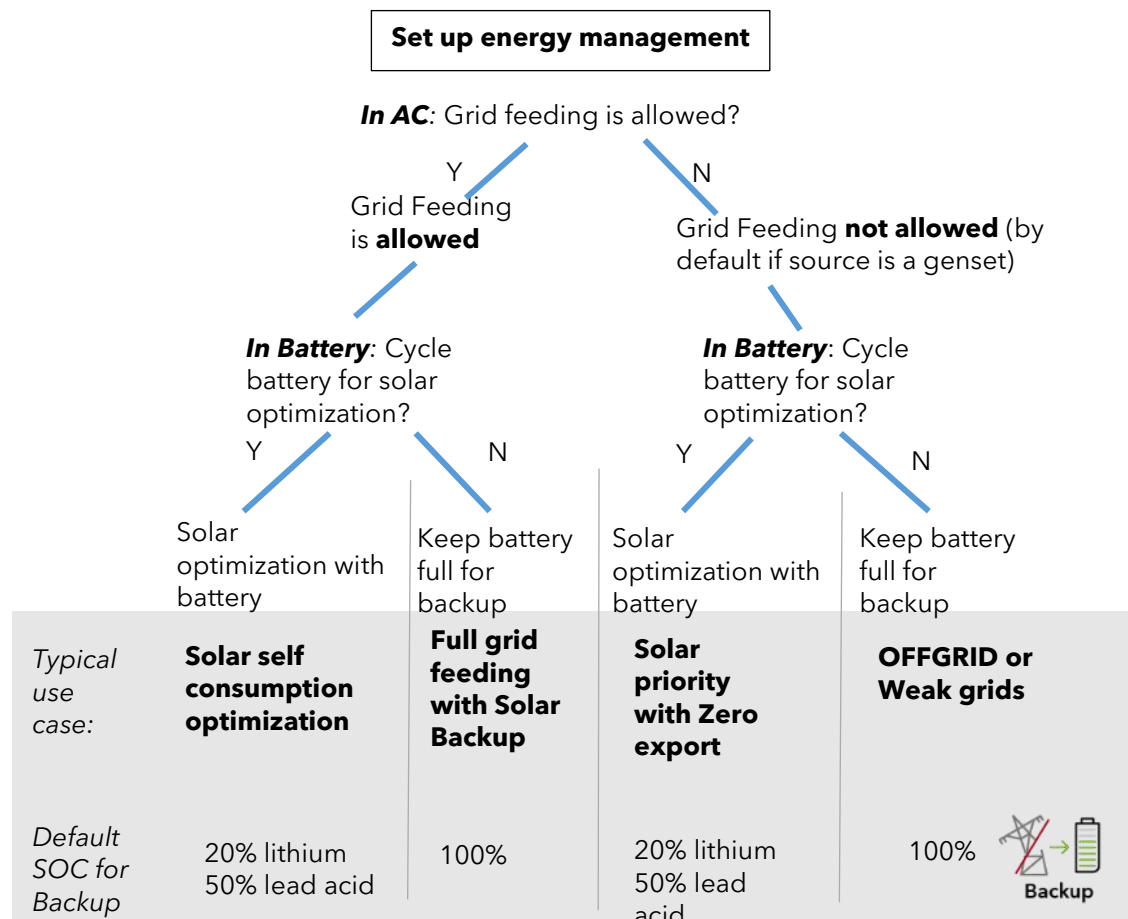
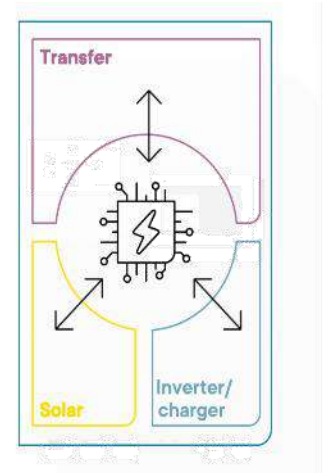

The 4 cases description, defined by those two questions are:

- Use of battery for **solar self-consumption optimization** until a state of charge (SOC) for Back-Up. During the night, the battery is discharged until the given SOC. Under the defined SOC level, a reserve is left in case of blackout. The default level is 20% to use 80% of the battery as buffer for lithium batteries and 50% for lead acid batteries. During the day, when

the solar power is produced, that energy is used to supply the AC loads, charge the battery³ and inject the excess energy to the grid.

- **Full grid feeding:** In this situation, the battery is kept full to be ready in case of blackout. The SOC for back-up is 100%. All the solar power produced supply the loads and the excess is injected to the grid.
- **Solar priority with zero export.** The solar power is used to charge the battery and to supply the loads but is never sent back to the AC-source. In that mode the grid-feeding is not allowed. The battery is used as buffer. When there is more solar than loads, the excess will charge the battery. When the loads are higher than the production, the energy is taken first from the battery. Only when it is at the lower threshold (SOC for Backup) the grid will be used. Like that, there is still some energy left in the battery to run some loads when a blackout happens. When the battery is full and the load is small, the MPPTs will reduce the production, causing some solar energy to be lost.
- **Offgrid or Weak grid:** AC-source is a genset or a grid where the injection is forbidden. The battery is charged to the maximum as soon as the AC source is present ensuring to have energy available in the next blackout event.

All the settings about this general behavior are set during the “Wizard” process. During the commissioning there are more information points to give such as amps rating, battery size and so on, but the general concepts of the types of systems are summarized with those 4 cases. See details in the section “Initial configuration with the Wizard” below where you’ll find the step by step description of the wizard with comments.

SOC for backup use is described with the picture below:

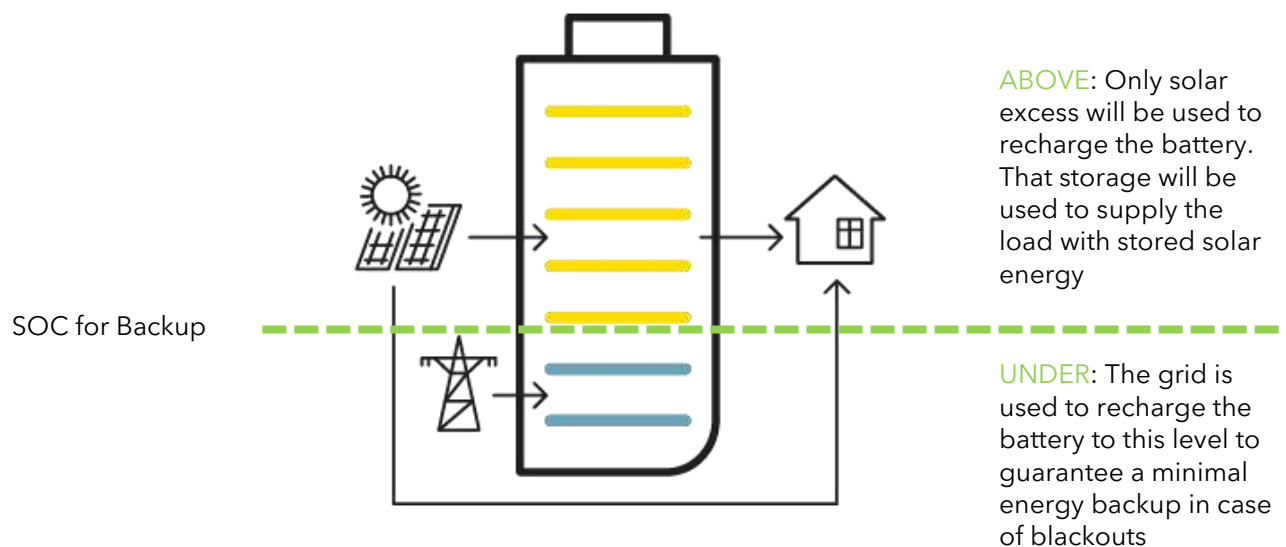

Note: it is possible to change the value of the “SOC for backup” setting from the default 20% in the battery menu. Per example to keep more reserve at some period of the year when blackout can occur more frequently (typically winter in Europe).

³ Battery is loaded up to the SOC for grid feeding level. SOC for grid feeding is 100% by default but it can be modified in advanced mode.

5.1.2 Standard use cases

Illustrations are provided below for the 4 basic use cases of the next3 or next1 with solar (either in DC or AC coupling).

Grid connected installation with grid feeding allowed and use of battery for self-consumption optimization:

Typical answers in the Wizard:

- Grid: YES with grid feeding
- Genset: NO
- Cycle battery: Yes

Default behaviour:

- Optimisation with battery use between 100% (SOC for grid feeding) and 20% (SOC for backup)
- If the grid is connected, the battery is charged only up to 20% with grid energy. Above that level, only the solar is used to fill the battery.
- Solar is used for the loads during the day as soon as SOC is above 30%.
- When the battery is full, excess is fed to the grid.

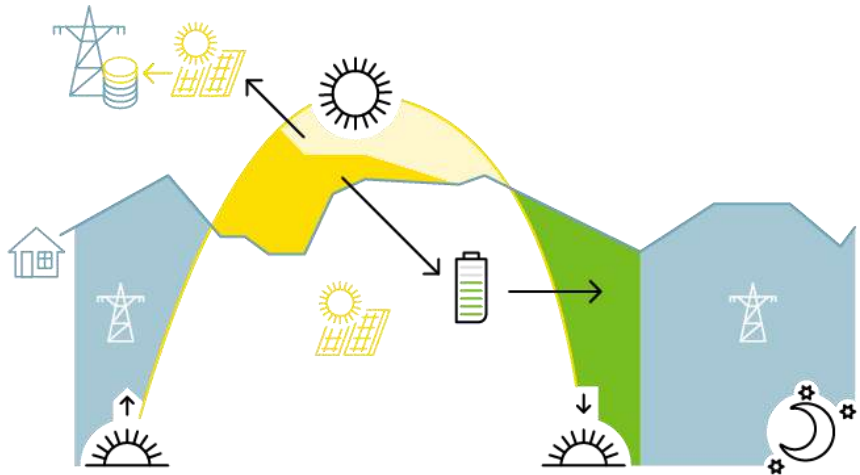

Grid connected installation with full grid feeding; the battery for **backup** (is not cycled):

Answers in the Wizard:

- Grid: YES with grid feeding
- Genset: NO
- Cycle battery: NO

Default behaviour:

- If the grid is connected, the battery is fully charged to 100% to be ready for a blackout.
- Solar is used for the loads during the day and excess is fed to the grid.
- Next3 is like a grid-inverter when the grid is always on.

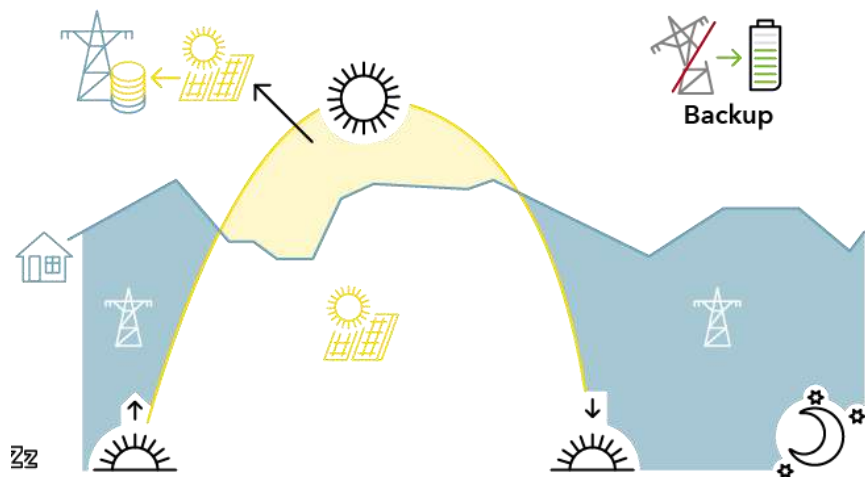

This is the configuration of UPS or backup use, with or without solar.

Solar priority without grid feeding: **zero export solar backup**

Answers in the Wizard:

- Grid: YES without grid feeding
- Genset: NO
- Cycle battery: NO

Default behaviour:

- Energy is never sent back to the grid.
- Solar is used for the loads during the day and to fill the battery, and excess is lost

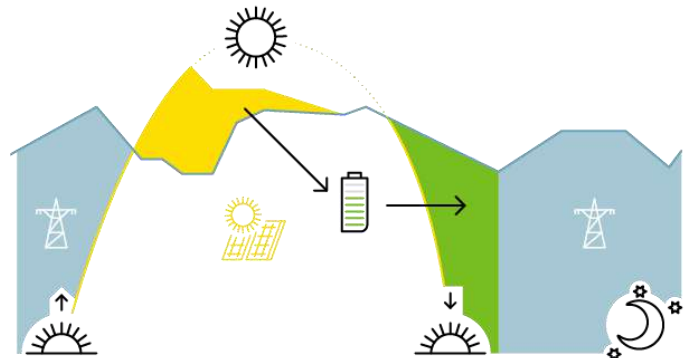

OFFGRID installation (back feeding on genset is forbidden!):

Answers in the Wizard:

- Grid: NO
- Genset: YES, on AC-source
- Cycle battery: NO

Default behaviour:

- Energy is never sent back to the genset.
- As soon as the genset is ON, the batteries are charged.
- Solar is used in priority for the loads during the day

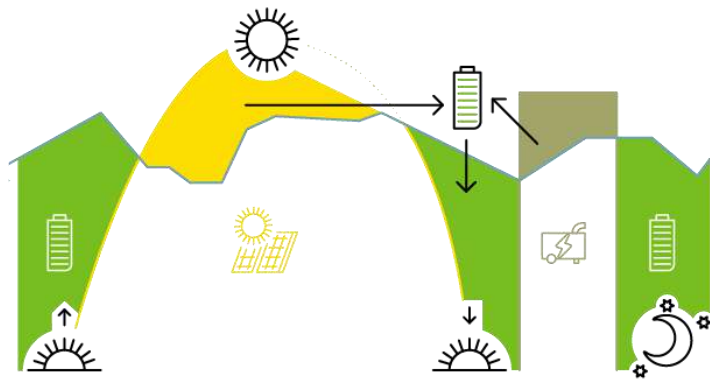



During operation, all the limits and constraints are automatically managed by the nx3/nx1. Power production and storage is optimally dispatched in the system due to the OPFD technology (Optimal Power Flow Dispatcher).

5.2 Configuration / Commissioning

The next3/1 has a configuration assistant called the "Configuration Wizard". With a set of questions, the user is invited to configure the unit according to the system specification. Very specific settings can always be accessed later in each component's menu. The settings are secured against inadvertent or unauthorized changes by the user level. The change of the user level is protected by password and must not be communicated to unauthorized personnel.

The next3/1 cannot operate until a first configuration with the wizard has been realized. The configuration wizard shall be done by an authorized person. If the initial configuration is not finished, the inverter does not start and the red light of the front panel blinks. That means without a proper selection/activation of the regional configuration (grid code) the inverter doesn't start and doesn't connect to the grid.

	The wizard is mandatory for the first commissioning. That means an nx-interface or possibility to run the webserver app (smartphone, laptop) are mandatory for the commissioning of an system.
---	--

	During the wizard process, the installation is stopped, and the AC power supply is stopped. Choose the proper moment to perform a configuration wizard.
---	---

Modification of the system, like adding new devices in the system, requires running the Wizard again with all elements connected. That is per example the case when a new inverter is added in parallel of the existing one.

At the first commissioning of the next3/1 has the "Configuration Wizard" will be automatically displayed. It is also possible to run it later by going to the nx-interface menu "Installation Configuration" (available at Expert level).

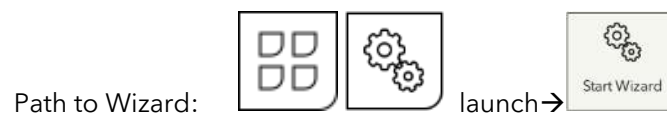

Run a wizard will reset all the settings with the factory values according to your configuration/answers to questions. Old configurations are completely erased with the wizard process.

5.2.1 Configuration storage in memory

The nx-interface operates as a terminal and is not mandatory in a system. It can be plugged into the system and removed. When an inverter/converter setting is modified using the nx-interface, or the webserver, or the portal, it is sent to the next3/1 and stored in the device permanently. If the nx-interface is removed from the system, this parameter continues to be used by the next3/1 with this modified value.

If the next3/1 is de-energized and then energized again, the settings can be retrieved from the non-volatile memory. This allows for example to pre-program a next3 at the workshop and to supply it to a customer, ready for his specific application.

5.2.2 Before first commissioning

The configuration Wizard is a list of questions asked one after another about the system. Simply follow the instructions. All points are fully described below.

The basic elements you must know about your system before commissioning are:

AC-grid

What is your grid connection?

- What is the capacity of the electrical source, typically given by the breaker size, per example 16A/25A/32/40A on each phase is common in houses.
- What is the grid-code to use? Generally, it is a single choice per country, but it may be many (per example there is Australia A, B or C)

AC-genset

- Do you have a genset in the system? If Yes
 - Is it single phase or three phased?
 - What is the rated current per phase going to the next1 inverter.
 - Per example an 18kVA three phased genset that can give 15kW:
 $15000/3/230=21.74$ A rounded down to 21A
 - It is often given by the breaker size going to the inverter and limiting the current.

Batteries

- What batteries do you have?
 - Type: lithium, lead acid?
 - Communicating? With which protocol? Be sure it is compatible before commissioning (and buying)
 - Number of battery modules and Capacity of one battery module and in Ah (per example an 5kWh battery at with 50V is $5000/50=100$ Ah)

Use this as a minimal checklist!

5.2.3 The Wizard explained step by step

In the first steps of the process, the wizard asks the language that will be used for the configuration and later.

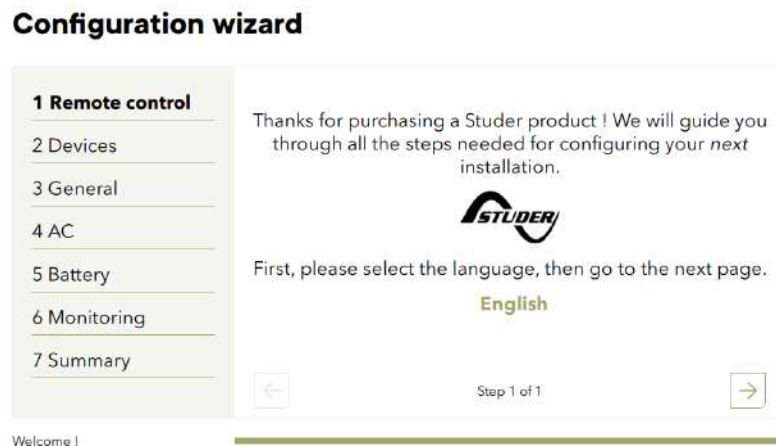

A scan of the devices present on the communication bus is performed:

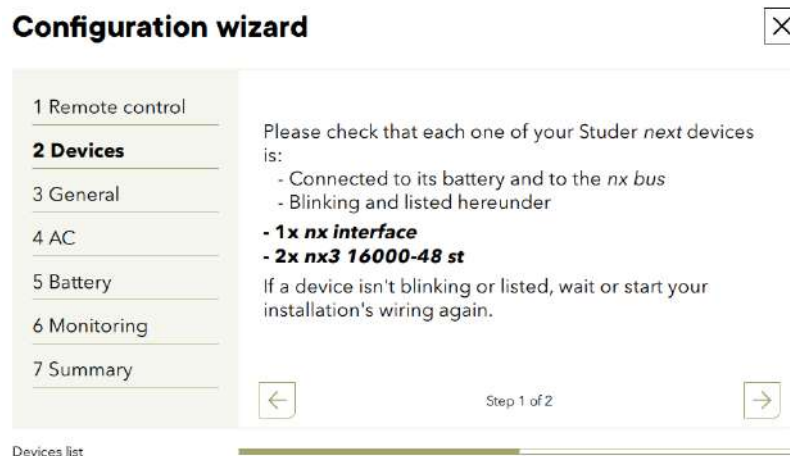

Check that all the elements you want in the system are connected. LEDs of front panel of the next are all blinking during this process. If not, that means the communication cannot be established. Check the communication cabling (presence of cable and termination switch) and that all the units are powered on (energized from a battery).

On a CAN bus, impedances are connected at the two ends of the communication line to "terminate" the line. Without those terminations as pull down resistors, the communication doesn't work at all. If the system doesn't see any nx3 in the system, check the nx bus termination switch on each device. It has to be on 'T' at the end of the line (when there is only one communication cable to the device) and on 'O' in between (when there are 2 communication cables to the device). In the next step, the system checks that 2 impedances are activated:

The termination switch is at the bottom of the next3: set T for terminated and O for open

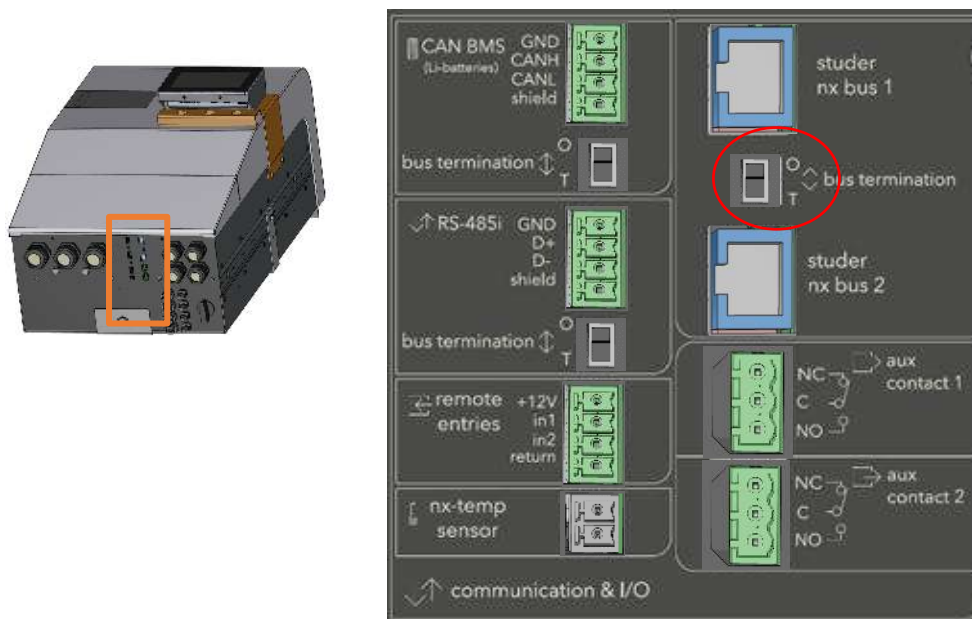

On the nx interface:

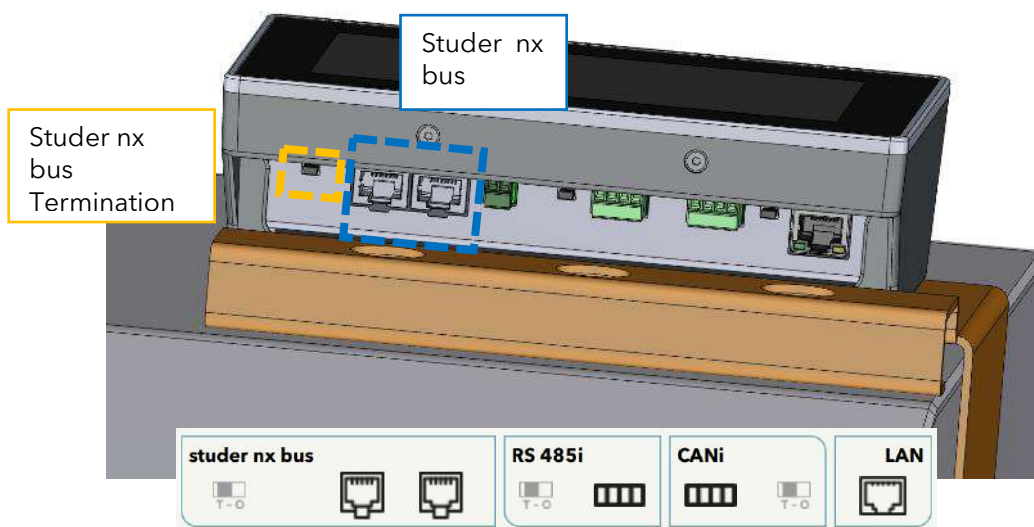

Inside of the nx1:

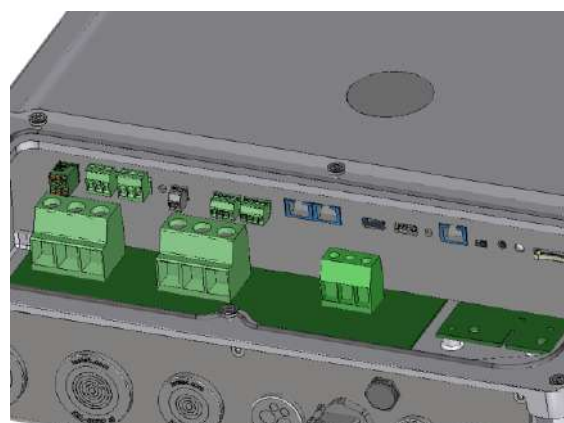

Once all devices are connected and detected by the nx-interface you can go forward. The country and time zone are set in the point 3: **general**:

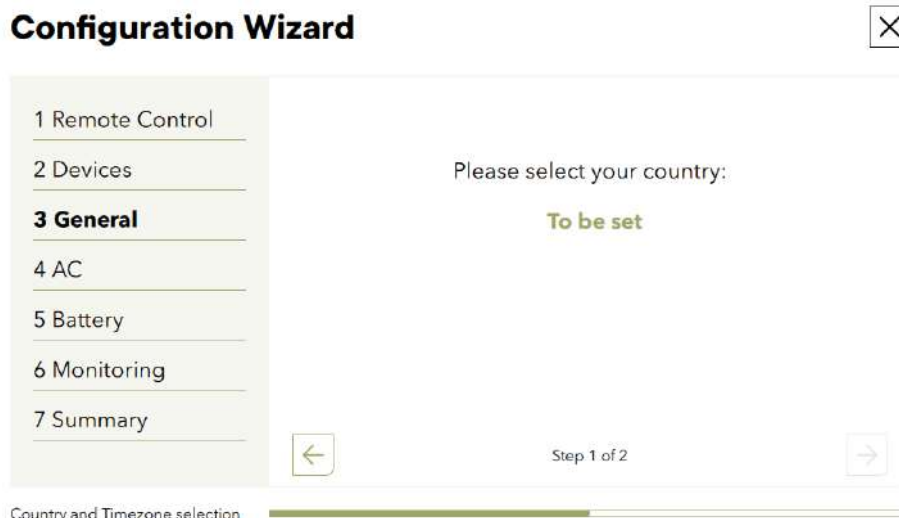

Country and Timezone selection

The country selection doesn't influence the grid code choice that is set with the AC configuration (to cope with different local rules in the same country):

Next step contains the question about the **AC** (sources and loads)

First question is to know if there is a grid or not connected to AC-source. The grid is always assigned to the AC-source due to the double security relays.

- If YES the properties of the grid connection are asked:
 - introduction amps (circuit breaker size)?
 - Is grid feeding allowed or not?
 - Which grid code must be used? the grid code must be set according to the DSO requirements.
- Those values cannot be changed later except with a complete reset of the system.
- In a multi-system, you must indicate which device is physically connected to the grid as there is only one device/transfer used per system. The selected device is blinking for a visual check.
- Don't connect a genset on the AC-source programmed for grid as the configuration is very different. If you have a genset, simply say no to this first question and the genset question is on the next page.



Grid configuration

In case of multi-units, the one wired to the grid must be identified:

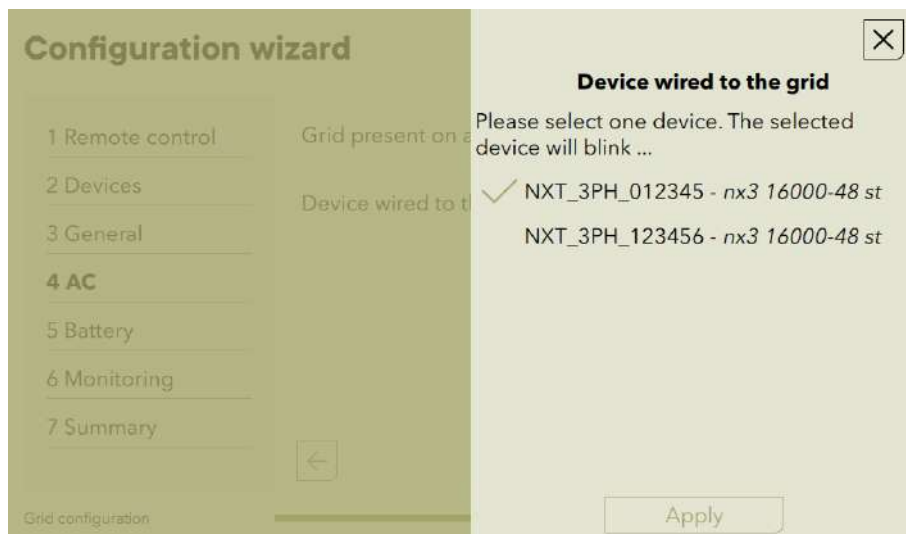

Use of the proper grid code is a legal requirement; you must be sure (as installer) to respect the local regulation. Associated with a general grid code (like the EN-50549), there can be special local settings. In case of doubt contact your local DSO (Distribution System Operator) before selecting the grid code in the country list:

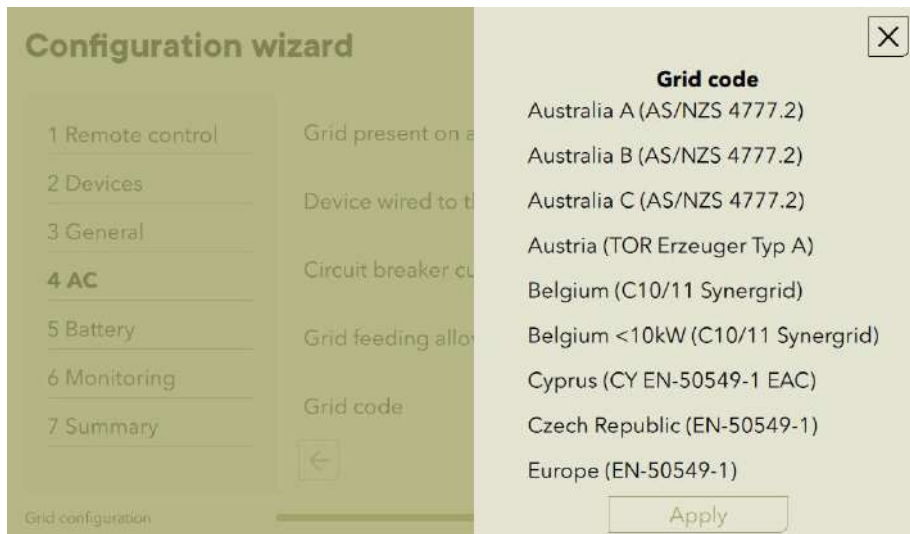

Then comes the genset questions, first to know if there's one in the system:

- If there is a genset, the user must indicate to which connection it comes. A genset can be connected to the AC-source or the AC-flex connection.
 - In a single device system, if the AC-source connection is used by the grid, only the AC-flex is left. If there is no grid (OFFGRID), the user has the choice to use AC-source or AC-flex. It makes more sense to use AC-source as it leaves the AC-flex for loads.
 - In multi-units system, if there is a genset, the connection could be done on any of the free AC-source or AC-flex and this must be indicated. It is better to use an AC-source connection if possible and let the AC-flex free for loads.
- The maximal power taken from the genset will be the lowest of the power given and the current limit.
 - When a genset is three-phase the power is divided by 3, and the power limited by the current of the circuit breaker expects a 230Vac.
- All AC-flex that are not explicitly given as AC inputs will be configured as loads, even if there is no specific question asking for it.

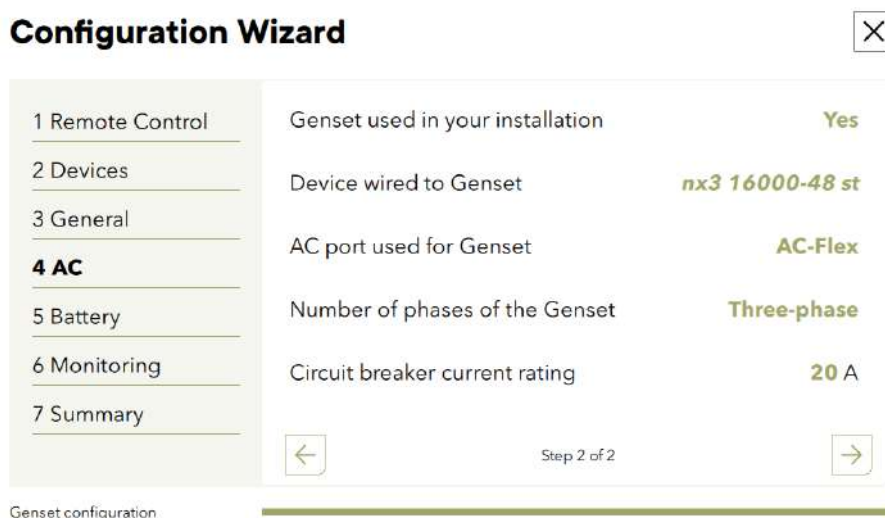

Per example without genset all AC-Flex are used for flex loads:

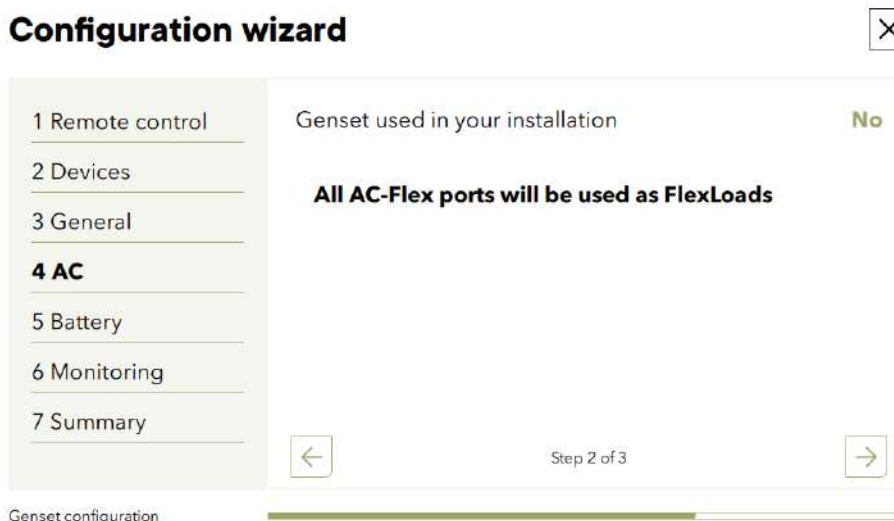
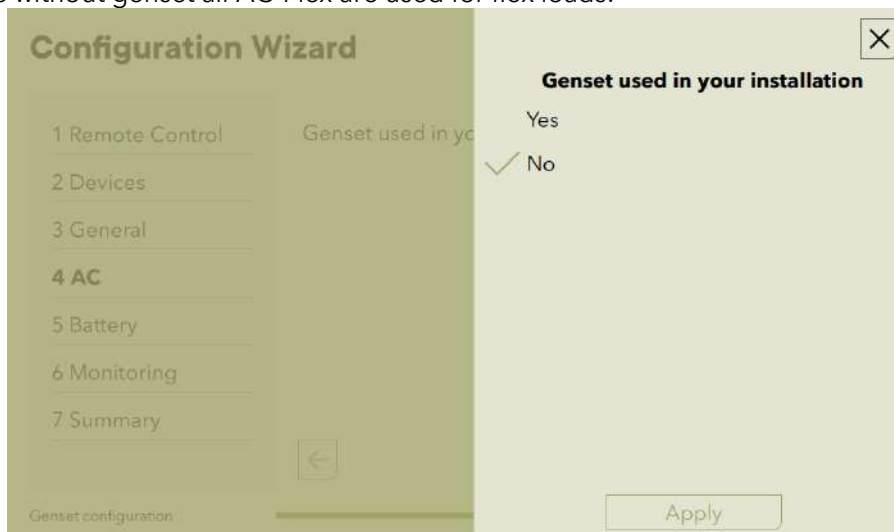

Last point for the AC is the question for the AC-coupling. If the grid inverter is connected to the AC-FLEX connection, you should make the proper settings for the AC-flex relays. See the AC-coupling chapter at the end of this manual for details.

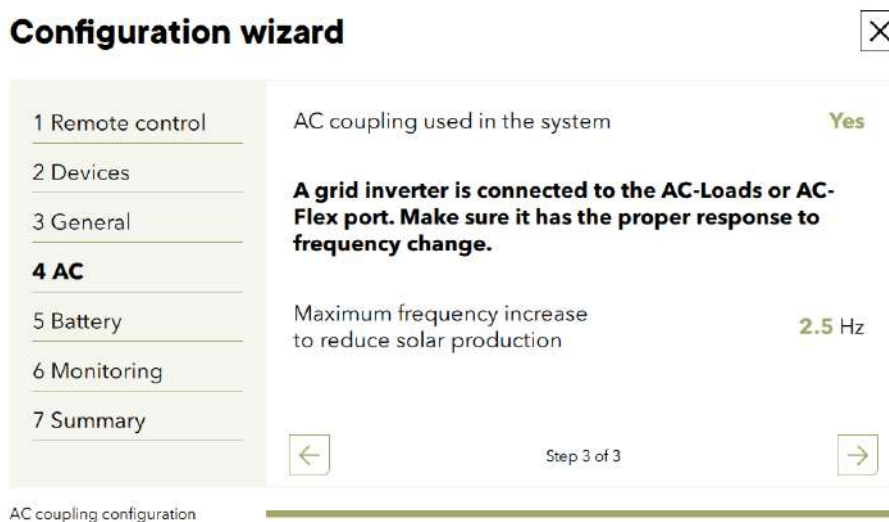

Then come the **battery** questions with, first, the choice if the battery is communicating or not is done. If not (simple lead acid batteries for example), then you must enter the type and the capacity in Ah.

Configuration Wizard X

1 Remote Control	Devices connected to battery 1	Devices 2, 3
2 Devices	Communicating battery	No
3 General	Technology	Gel
4 AC	Nominal capacity	500 Ah
5 Battery	Cycle battery for solar use optimization	No
6 Monitoring		
7 Summary		

←
Step 2 of 2
→

Battery bank 1 of 1 Specification

The capacity is asked in Ah, if this is not given directly by the manufacturer this is obtained with the formula: kWh / voltage x 1000

The non-communicating batteries are generally lead batteries. Choose the appropriate type in the proposed list. In case of doubt select AGM batteries: it has the less risky levels (lowest voltages) for any types of batteries, even if the charging would not be optimal for other cases:

Battery type	Floating voltage	Absorption voltage/period	Equalization	Charge current
Flooded Lead Acid (without equalization)	54.4V	57.6V / 2h	No	C/5
Flooded Lead Acid (with periodic equalization)	54.4V	57.6V / 2h	63.2 V during 30min- every 30 days	C/5
GEL	55.2V	56.8 / 2h	No	C/10
AGM	53.6V	57.2V / 2h	No	C/3

There is no reduced floating phase or periodic absorption phase for any of those choices by default.

If you are not satisfied with one of those pre-sets, you can go to the battery menu later and adjust the levels as you want.

The battery capacity is generally given in Ah for lead batterie and other special types. For a battery bank composed of many cells, the arrangement gives the total capacity. To calculate the capacity, only one cell capacity must be considered in a series and not the sum. If the battery bank is composed of several series/strings in parallel, the total capacity is the sum of the capacities in parallel.

Per example a with 24 units of a 200Ah/2V cell in series, the total battery bank is 200Ah 48V. With 72 cells arranged in 3 strings of 24 units, the bank is 600Ah 48V.

To determine the charging current, the most frequently used value is of one fifth of the battery capacity. Ex. for 500Ah: 500/5 = 100A. See manufacturer indication for details.

If the battery has a communication BMS (typically for lithium battery), you'll have to choose the manufacturer in the list for the next3 to use the proper communication protocol. Verify that the manufacturer is in the compatible list (before buying the batteries!).

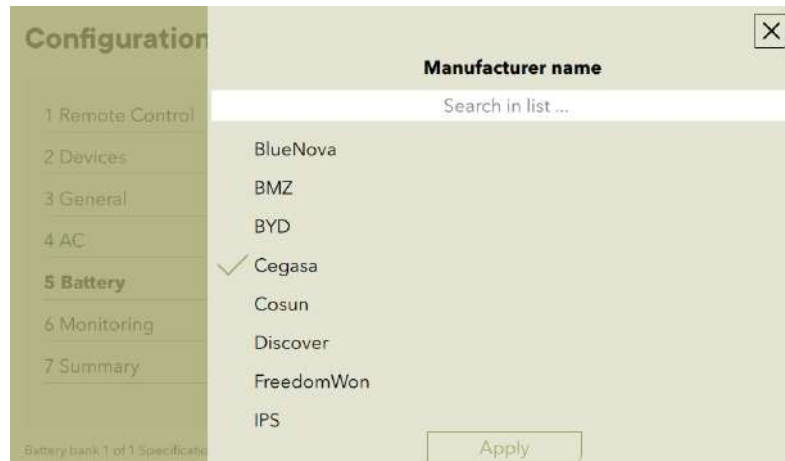

Then enter the capacity of the battery. Very often the lithium battery has a capacity given in kWh and not in Ah. Convert with the following formula:

$$\text{Capacity in kWh} * 1000 / \text{Battery voltage} = \text{Capacity in Ah}$$

For example, a 14kWh at 50V battery has 280Ah.

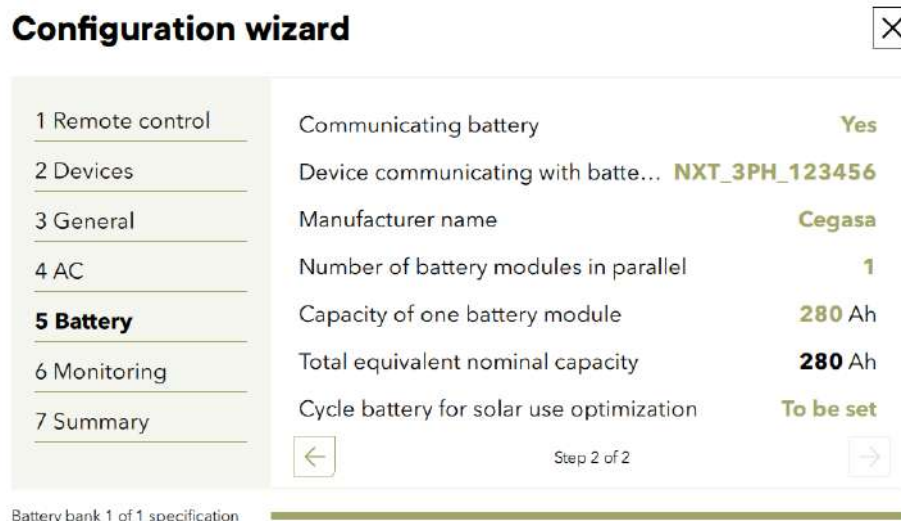

At the end is the second important question for the energy strategy:



If the battery cycling is wanted (charge-discharge frequently), the SOC for backup will be set to 20% (for lithium and 50% for lead acid). If not, it will be set to 100%.

In case of multi-unit system, the number batteries is asked first

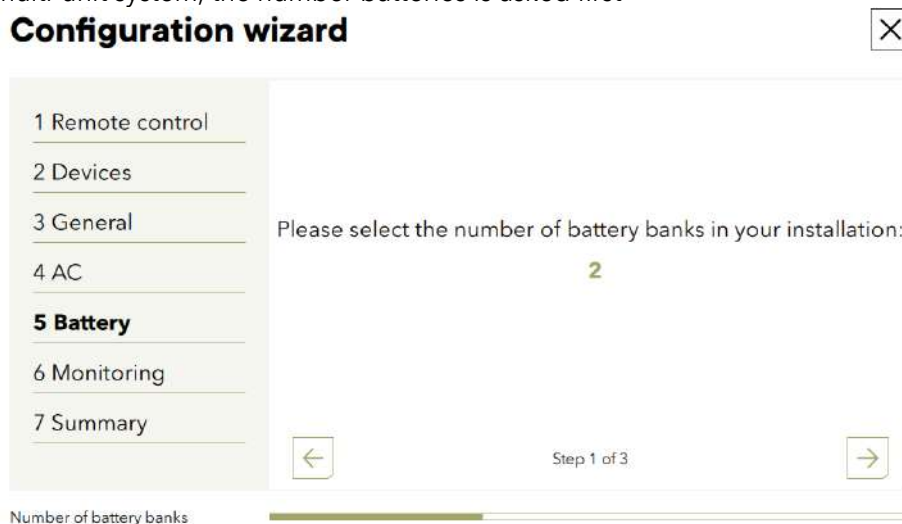

And then each battery must be associated with its next3 correctly (with the blinking of LEDs identification and serial number is displayed).



For a single battery in a system with multiple next3, it is necessary to say which next3 is physically connected with the CAN communication cable as only one device communicates to the BMS.

Configuration wizard



1 Remote control	Devices connected to battery 1	NXT_3PH_012345
2 Devices	Communicating battery	To be set
3 General		
4 AC		
5 Battery		
6 Monitoring		
7 Summary		

Step 2 of 3

Battery bank 1 of 2 specification

If your next3 is connected to internet and to the Studer web portal (www.portal.studer-innotec.com) you must make the pairing with your account. This is done with the unique number called GUID. Copy exactly this number on both side for pairing. A GUID can be generated by the nx-interface, or by the web portal. This number can also be found at the bottom the .csv datalog file stored daily in the USB key.

Configuration Wizard



1 Remote Control	The GUID is used to communicate with the Studer Webportal.
2 Devices	The current GUID value is :
3 General	NAATWCBTIG36W7UXILJZ5GXU6TIBVB3K
4 AC	Generate new GUID on this nx-interface : <input type="button" value="Start"/>
5 Battery	<small>A new GUID has been generated and saved. Now, please make sure this new GUID is set in the Studer Webportal, in your account's Installations parameters.</small>
6 Monitoring	Automatically get new GUID from Webportal : <input type="button" value="Start"/>
7 Summary	Manually enter new GUID : <input type="button" value="Start"/>

Step 1 of 1

Generation of the GUID

This GUID must be copied on the webportal in the GUID field when creating a new installation:

Enter information about the installation

Name

Type of installation

Guid

Cancel Save

The remote monitoring can be restricted to “view only” access. This option is checked by default (security by default). Uncheck it if you want to be able to remotely change settings after the commissioning. This can be very useful for the installer to avoid travelling physically to the site for some adjustments. The communication infrastructure of Studer-Innotec is up to date and secure but some customers want a restriction of this functionality:

Configuration wizard

1 Remote control

2 Devices

3 General

4 AC

5 Battery

6 Monitoring

7 Summary

Webportal control as read-only

Enabling this setting will lock the remote write operation, and prevent remote controlling of your installation from the Webportal, web services and mobile application.

Step 2 of 3

Security configuration

Finally, the terms and conditions of the webportal must be accepted for privacy reasons. The load curves are personal data and the end user must give its agreement that the data are sent to Studer-Innotec. Else the next3 will work normally but will not connect to the portal.

Final check: a summary of the installation is given and the configuration process is finished. Press “Start using the system!”

Configuration Wizard

Please check that your installation is correctly configured, then go to the next page to start writing the new configuration to your installation.

Select a Device in the list to make it blink.

Blink	Device description	Battery num	Phases
<input type="checkbox"/>	no interface	-	-
<input type="checkbox"/>	nb3 15000-48 V	1	1-1A2A3
<input checked="" type="checkbox"/>	nb3 15000-48 V	1	1-1A2A3

Step 1 of 2

Installation Verification

Configuration Wizard

Congratulations!

You configured your *next* installation successfully!

Start using the system!

Step 2 of 2

Configuring Installation ...

After the first configuration with the wizard, the next3 is ready to be used.

5.3 AC-Source

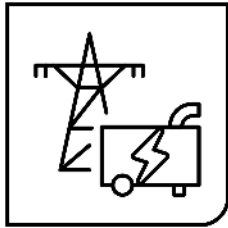

5.3.1 General information

The next3 is a hybrid inverter charger, that can work in a stand-alone (offgrid) mode or connected to an external AC source, being a grid or a generator.

The next3 has a connection named "**AC-Source**" where the main AC source is connected: the grid or a generator.

This input:

- is limited to 80Aac and is designed for 3 phases system 400Vac with neutral.
- has a high security level with double security relays for disconnection according to VDE-AR-N 4105, EN 50549-1, IEC/EN 62109-1 and other standards. In case of connection to a distribution grid, always connect the grid to AC-Source. The proper opening of the relay is checked with measurements.
- is unique in a system. Only one AC-Source is physically connected in a system even with multiple next3 devices.

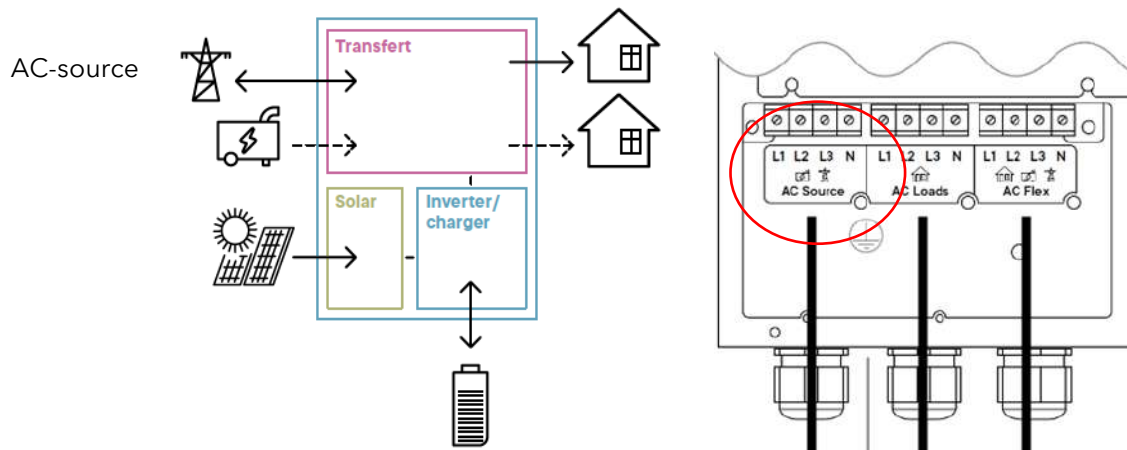

- The maximum accepted voltages at the input are by default (for grid connection, VDE values):
 - 125% of nominal voltage for 10ms (for fault ride thought: $230 \times 1.25 = 287.5V$)
 - 120% for 5 second: $230 \times 1.2 = 276V$
 - 115% for 60sec means: $230 \times 1.15 = 264V$

5.3.2 AC-source Information

Detailed information about the grid is available by clicking on the AC-source picture of the synoptic screen (see screens map for an overview of navigation).

There are dedicated screens for AC-source information (see the screen map). On the L1-L2-L3 screen, the sum of all phases is displayed as well as the composed voltage (phase to phase).

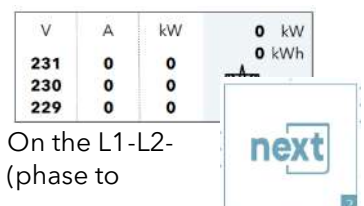

The scale for the max power is given with the current given by the maximal power introduced during the wizard process.

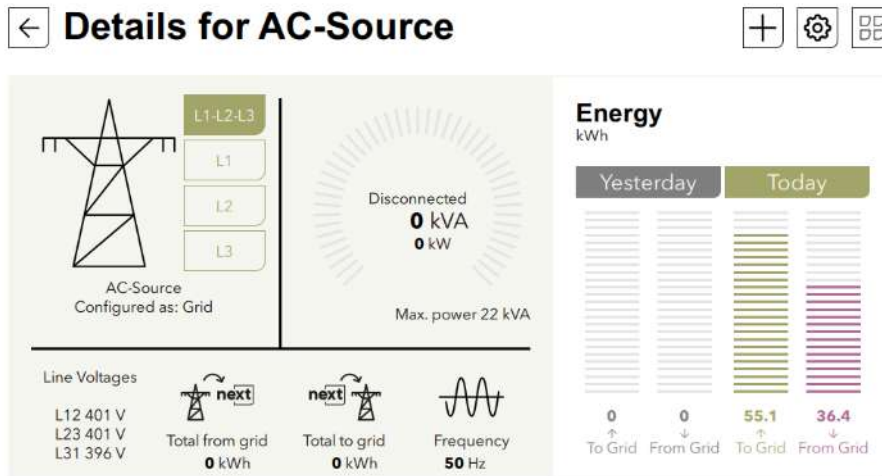

The detailed information about all voltages and currents for each phase is available with a click on the phase number:

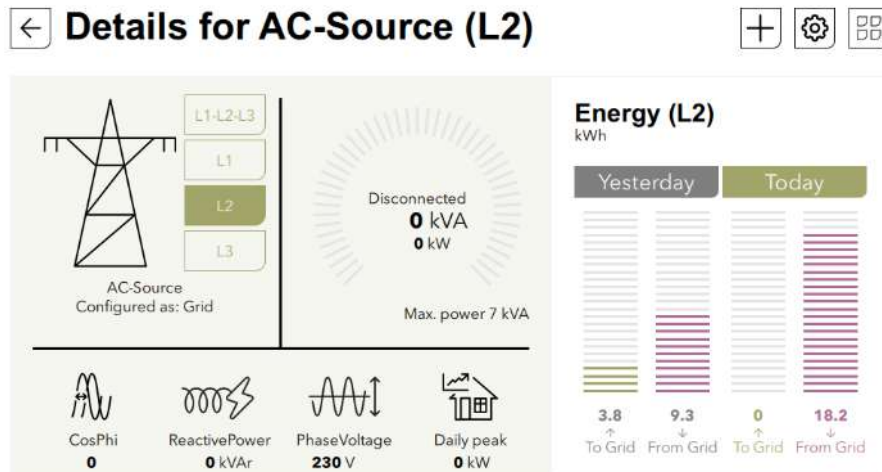

Similar view is given if a genset was configured for the AC-source:

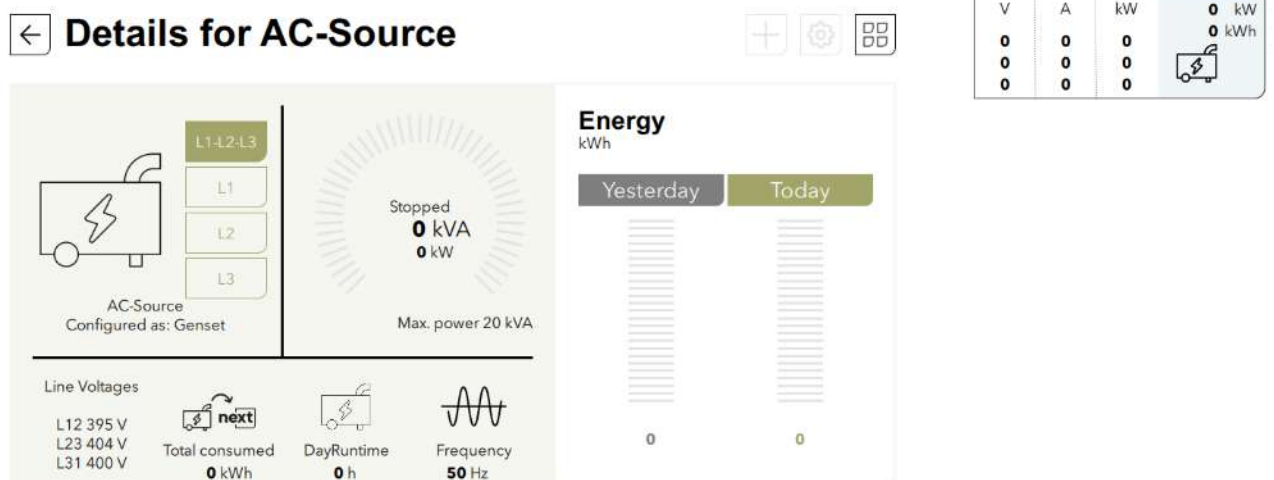

 The full list of available information is accessible with the '+' and is described in the appendix. Unique identification numbers are used to clearly identify each information value.

 **AC-Source : Information list**



PreviousDayPeakActivePower	0 W	ID 2.1.1.37
2.1.2 - L1		
Frequency	50 Hz	ID 2.1.2.0
PhaseVoltage	231 V	ID 2.1.2.4
Current	0 A	ID 2.1.2.8
ActivePower	0 W	ID 2.1.2.12
ReactivePower	0 VAR	ID 2.1.2.16

5.3.3 AC-source Settings for Grid

The wizard is mandatory for a proper setting of AC-source as many points are configured during commissioning and cannot be changed later. Carefully read the questions to avoid mistakes in your answers.

One example is the grid code setting that must be set according to the DSO requirement by the qualified installer and cannot be changed later by the end-user. The end-user has no access to this parameter as it is protected by the EXPERT code.

At BASIC level only the following settings are accessible:

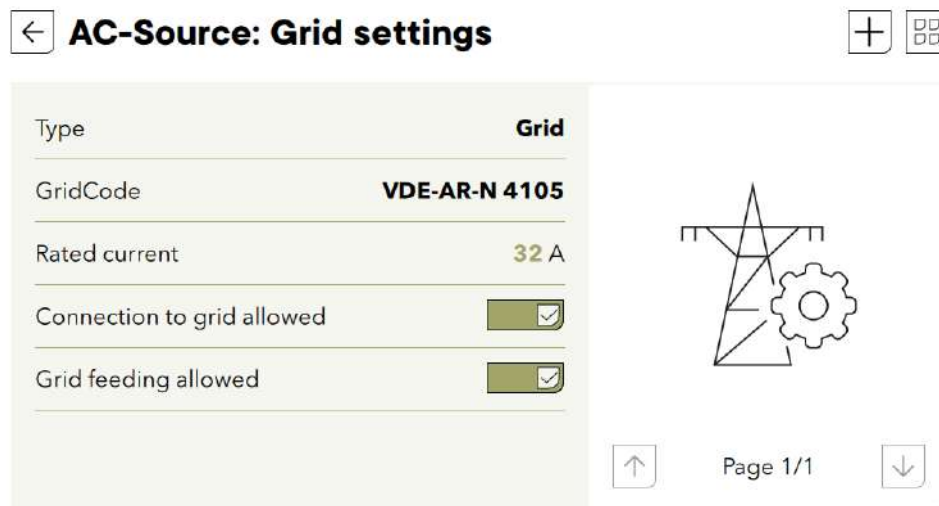

Concerning the grid code, the anti-islanding function implemented is based on the power variation method (called also "vector shift" method in EN and VDE). The reactive power management with functions Q fix, Q(U), $\cos\phi$ fix and $\cos\phi$ (P) can be configured, if necessary, after the wizard. The general control function (section 6 of AS-NZS 4777.2) is not implemented. The multiple inverter combination (section 5 of AS-NZS 4777.2) does not apply as the next3 is an all-in-one three phase inverter.

5.3.3.1 Reactive power management

Power injection in networks has the effect of increasing the voltage due to the impedance of the line. This is the opposite effect of the voltage drop with consumers. To compensate for local voltage increases in the network due to distributed generators, the DSO can require that the distributed devices produce reactive power.

It is possible to activate various operating modes managing the reactive power in the next3:

- Generate at a certain $\cos(\phi)$:
 - Fixed
 - Depending on the active power produced
- Generate reactive power depending on the voltage
- Produce reactive power directly.

The injection of reactive power, in addition to the production of energy with active power, makes it possible to correct the effect of the active power. This is highly dependent on the impedance (Z) of the line/cable, if it is more resistive (R) or reactive (X).

Do not activate these functions without the approval of the DSO. They must be calculated by him according to the properties of the lines. The production of reactive power generates losses in the next3 device and in the lines and is not necessary in most cases.

These settings are accessible in EXPERT(=Professional) mode. They are located in the network section of the nx-interface. Use the "+" button to access the list of advanced settings:



The choice of the type of reactive power production is made with parameter 2.1.5.50.

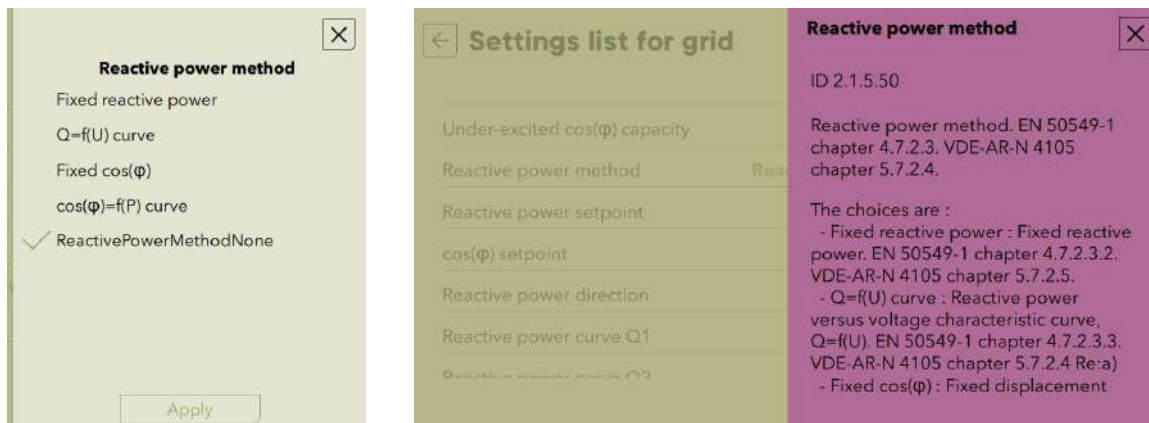

The maximum reactive production range required by the standards is a $\cos(\phi)$ of ± 0.9 . Beyond this, the inverter is not obliged to supply reactive power and this limit is respected in all operating modes.

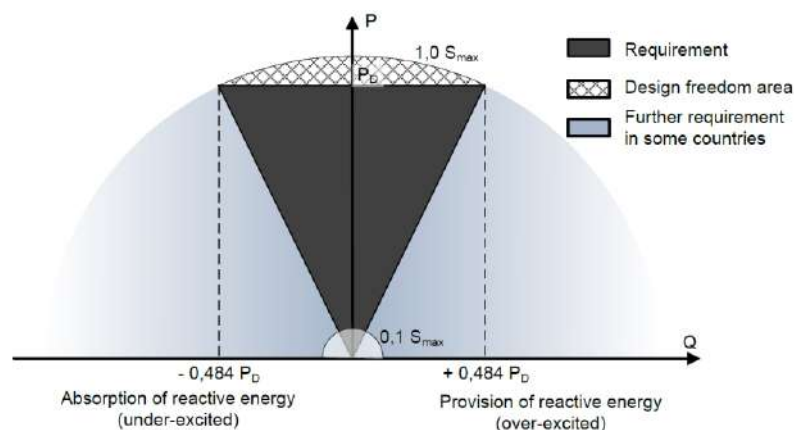

The sign convention used in the settings is identical to the figure above. The reactive load of the inverter (= as an inductive load that reduces the voltage) has a negative sign.

The details for each of the operating modes are:

- For fixed $\cos(\phi)$:

- Set the desired $\cos(\phi)$, typically 0.96
- Use underexcited, i.e. as an inductive load so that the effect is a voltage drop on an inductive line.

$\cos(\phi)$ setpoint	1	ID 2.1.5.52
Reactive power direction	Under-excited	ID 2.1.5.53

- For $\cos(\phi)$ versus power: it is possible to define the point at which the reactive power is produced. Indeed, when the production is low, the voltage increases are small and do not require countermeasures. The signs of the reactive power produced are explained with the titles :
 - OE=Over-Excited
 - UE=Under-Excited

React. pow. curve $\cos(\phi)$ OE1	1	ID 2.1.5.66
React. pow. curve $\cos(\phi)$ OE2	1	ID 2.1.5.67
React. pow. curve $\cos(\phi)$ UE3	1	ID 2.1.5.68
React. pow. curve $\cos(\phi)$ UE4	0.9	ID 2.1.5.69
Reactive poewr curve P1	0 %	ID 2.1.5.70
Reactive poewr curve P2	10 %	ID 2.1.5.71
Reactive poewr curve P3	50 %	ID 2.1.5.72
Reactive poewr curve P4	100 %	ID 2.1.5.73

The general curve is given below:

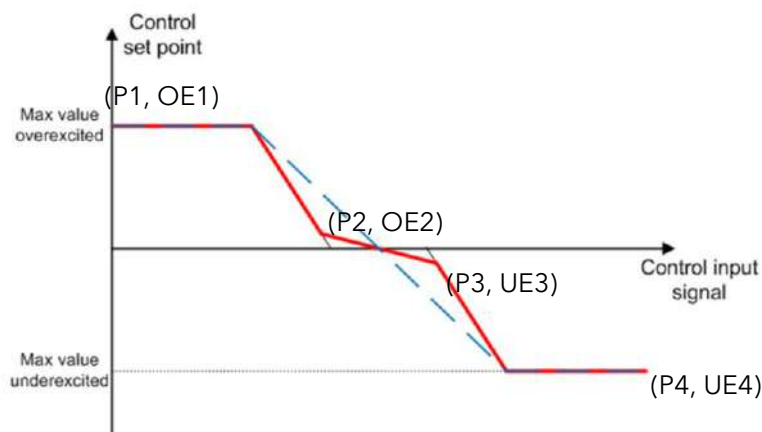

And its typical use is:

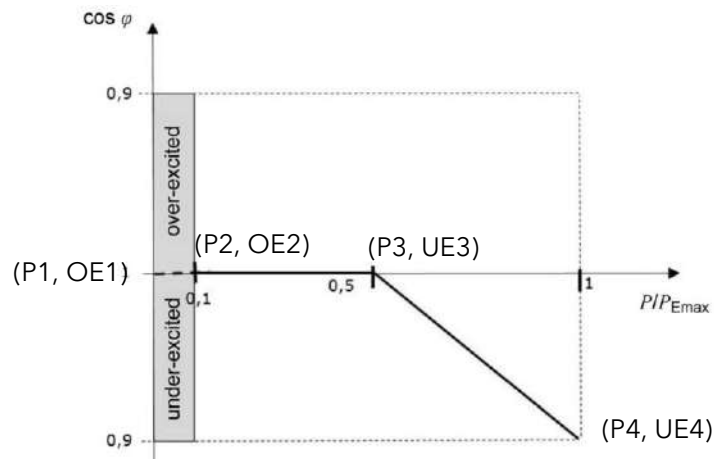

- For $\cos(\phi)$ versus voltage: in this case, reactive power is produced only if the voltage increases (or decreases) according to certain thresholds. The maximum reactive power (100%) corresponds to a minimum $\cos(\phi)$ of 0.9.

Reactive power curve Q1	100 %	ID 2.1.5.54
Reactive power curve Q2	0 %	ID 2.1.5.55
Reactive power curve Q3	0 %	ID 2.1.5.56
Reactive power curve Q4	-100 %	ID 2.1.5.57
Reactive power curve U1	93 %	ID 2.1.5.58
Reactive power curve U2	97 %	ID 2.1.5.59
Reactive power curve U3	103 %	ID 2.1.5.60
Reactive power curve U4	107 %	ID 2.1.5.61

The control signal is the voltage and the controlled variable is the reactive power:

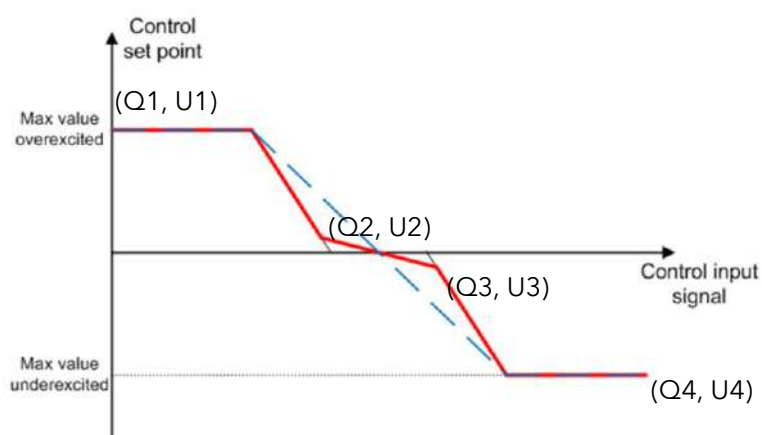

The typical use of this function is given below:

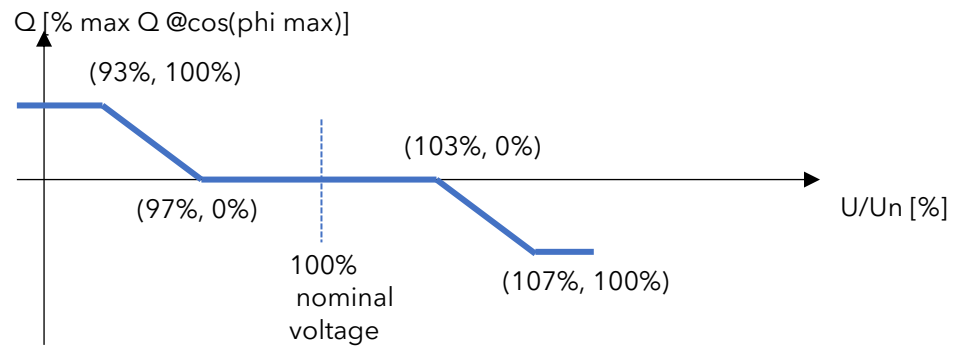

- For fixed reactive production: use setting ID 2.1.5.51 in % of nominal power. It is useful for a system where an external controller dynamically manages the reactive power by sending instructions via Modbus. The reactive power is limited by the $\cos(\phi)$ min which is 0.9 by default.

Note: In case of stability problems, the reaction speed (PT1 filtering) can be adjusted with ID 2.1.5.62. Details can be found in the VDE and EN standards mentioned as reference.

Reactive power setpoint ✕

ID 2.1.5.51
Unit [%]

Produced reactive power setpoint, percentage of rated active power. Negative value for a consumed reactive power. EN 50549-1 chapter 4.7.2.3.2. VDE-AR-N 4105 chapter 5.7.2.5

5.3.4 AC-source Settings for Genset

The wizard is mandatory for a proper setting of AC-source as many points are configured during commissioning and cannot be changed later. Carefully read the questions to avoid mistakes in your answers.

If the source is a genset, the available settings are given on 2 screens:

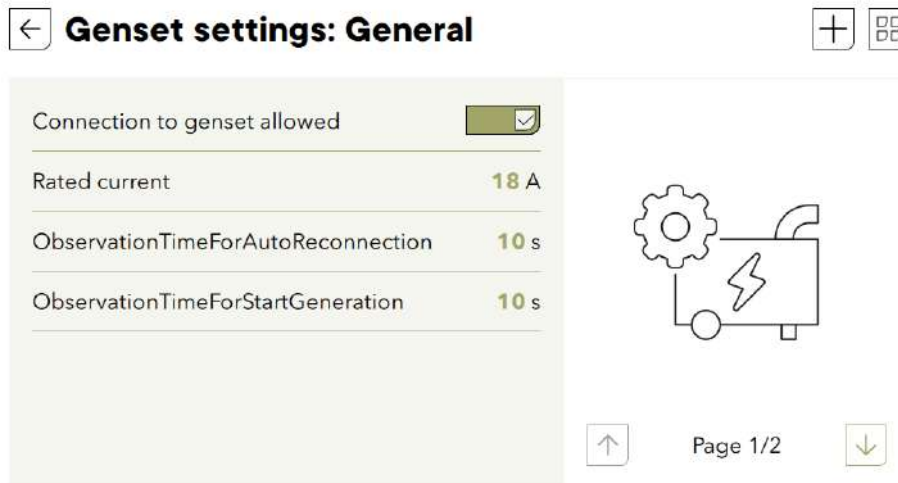

The rated current taken on each phase can be changed on the fly when the generator is running to adapt to its real ability.

The *Observation Time* can be understood as a delay for the genset to warmup.

The tolerances on the voltage fluctuations of the genset can be adapted:

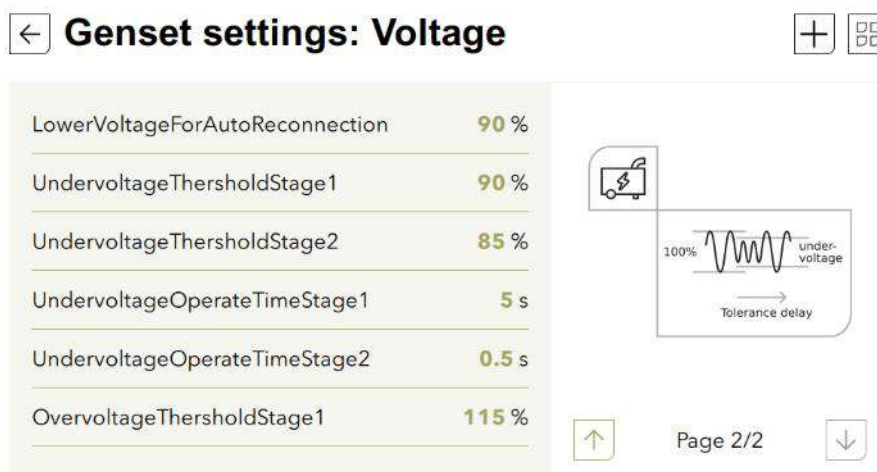

5.4 Solar PV (for next3)

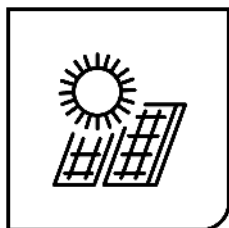

This chapter applies to the next3 device only as there are no solar entries on the next1.

Two strings of solar photovoltaic modules can be connected to the next3 with two independent MPPTs. Indications about the connection and dimensioning of the PV array is given in the “Wiring” chapter **Erreur ! Source du renvoi introuvable.** Be careful to meet the electrical specifications and never exceed the maximal values to avoid damaging the unit.

This section explains the operation of the solar MPPTs. All information and settings are accessible via the nx-interface.

5.4.1 General information

The next3 is a renewable energy friendly converter and always try to optimize the solar part in the system. For a standard user, there is nothing/little to modify for the solar converter: as soon as there is solar energy, the next tries to use it first.

All the settings about this general behaviour are set during the “Wizard settings” process. During operation, all the limits and constraints are automatically managed by the NX3. Power production and storage is optimally dispatched in the system thanks to the OPFD technology (Optimal Power Flow Dispatcher®).

The solar grid feeding can be authorized or disabled depending on the AC Source type: grid or genset. There are dedicated screens in the AC-source settings on the wizard where you chose if grid feeding is allowed or not.

The PV production depends on the irradiance on the PV modules of course, but also on other constraints in the system:

- If it is an off-grid system, the solar energy will directly supply the loads and charge the batteries. However, if the battery is full and the loads are small, the solar production will be reduced. That is because the energy can go nowhere, so the excess is lost to avoid overcharging the battery.
- The charging limits are given by the battery settings (see Battery section 5.5). The next3 smart inverter can be connected to lithium batteries with communicating BMS on CAN bus (see compatible list in chapter **Erreur ! Source du renvoi introuvable.**). In that case the manufacturer BMS decides the voltage levels and currents that are optimal for the battery. There are dedicated screens for the battery settings on the wizard.
- During grid feeding, the max power will be limited according to the AC-source breaker amps configured during the wizard.
- The solar production can be limited according to the grid code that requires grid support function, for example the production reduction in function of the grid frequency.

To optimize the solar power use, for example with dump load connection, you can use the AC-Flex connection or the auxiliary contacts. See the section “AC-Flex” (chapter 5.7) and Aux-contacts” (chapter 5.9.3) to adjust their settings for solar maximization.

The proper insulation of the PV+ and PV- is checked at every start-up. An error will be shown on the screen if there is ground fault and the solar part of the inverter doesn't start for security reasons.

5.4.2 Solar Information

The solar MPPT electrical information can be seen on the remote control nx-interface, on the web portal and the APP (if connected) or accessed through communication (MODBUS TCP or RTU). On the nx-interface, the synoptic info screen shows the power fluxes in the system in kW. This view shows the solar power sum of all devices (all solar chargers, all nexts, ...) in the communication bus. Detailed information about all voltages and currents for each MPP entry is available by clicking on the solar picture of the synoptic screen (see screens map for an overview of navigation).

The detailed screen shows the information of only one MPPT channel at a time. Swipe right or left to access the information from the other MPPTs.

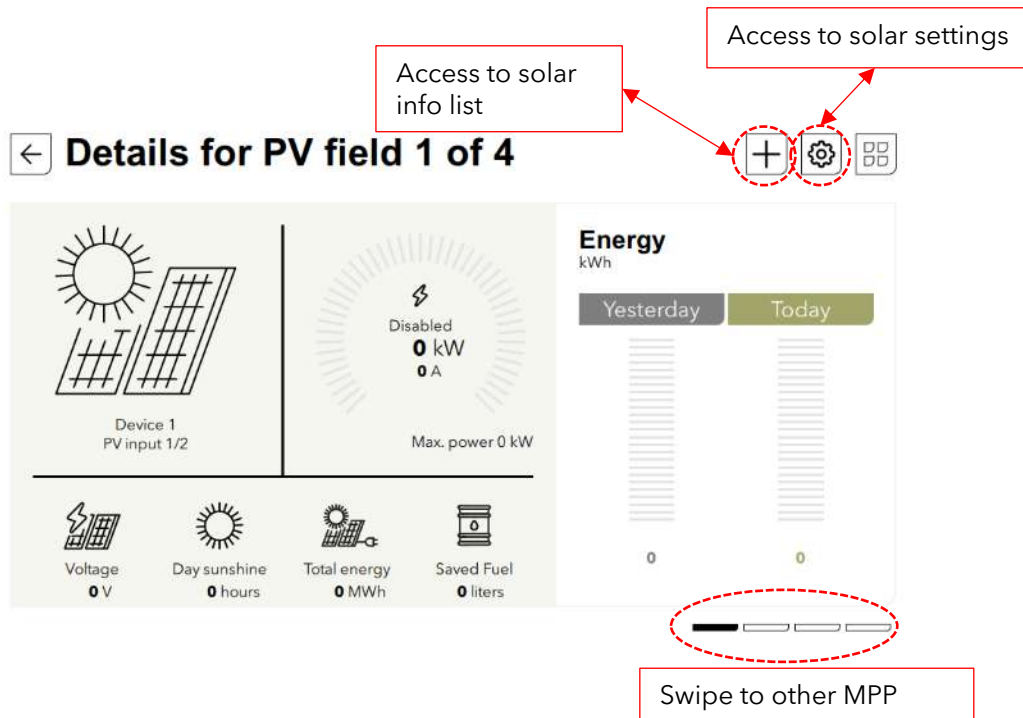
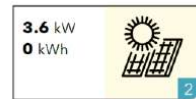

Note: one nx3 device has two (2) PV MPPT inputs and there are therefore two screens. In case of multi-inverter system, you can swipe from one solar charger to the other. The picture above shows the case with 2 nx3 and then 4 MPPTs.

Comments about the information displayed on the nx-interface:

- The power, voltage and current displayed are an average of 1 second
- The charged and discharged energy of the day are calculated from midnight to the actual time. The energy of yesterday is computed from 00:00 to 23:59 the previous day.

The state information are:

- **Production:** The converter is producing normally, without limitations
- **Current Limited:** The converter is producing but limited because the maximum current is reached
- **Temperature Limited:** The converter is producing power but is limited because of the temperature (temperature derating is applied)
- **Solar Excess:** The converter cannot convert all the available energy because there is no way to use it (battery full, no load, no grid feeding, etc.)
- **Night:** The converter is not producing because there is not enough sun to work properly (night)
- **Dawn/Dusk:** there is voltage on solar generator but not enough to start the equipment.
- **Disabled:** The converter is disabled. The equipment is manually turned off by the operator with the main on/OFF button, the nx-control, or communication.
- **Starting:** The converter is starting
- **Error:** Some errors are pending, prohibiting the converter to work properly. See the

messages list for more information.

The total energy is the recorded since the first start of the next
The saved fuel is computed on the base of a standard genset efficiency in hybrid systems (25% efficiency on diesel, which is even quite optimistic, that mean the savings are probably higher than this estimation).

5.4.3 Solar Settings

There is no “wizard screen” for solar part as the next3 is “plug n play” for standard applications. Connect PV modules with proper voltages according to the next3 specifications and as soon as there is sun, the solar charger works automatically.

The default configuration is:

- PV ground fault is checked
- Best algorithm chosen: LSF
- No depolarization during the night
- A global check of the MPP is done once per hour to avoid local maxima (can happen with shading).

From the info screen of the solar, the settings are accessed with the configuration button. 

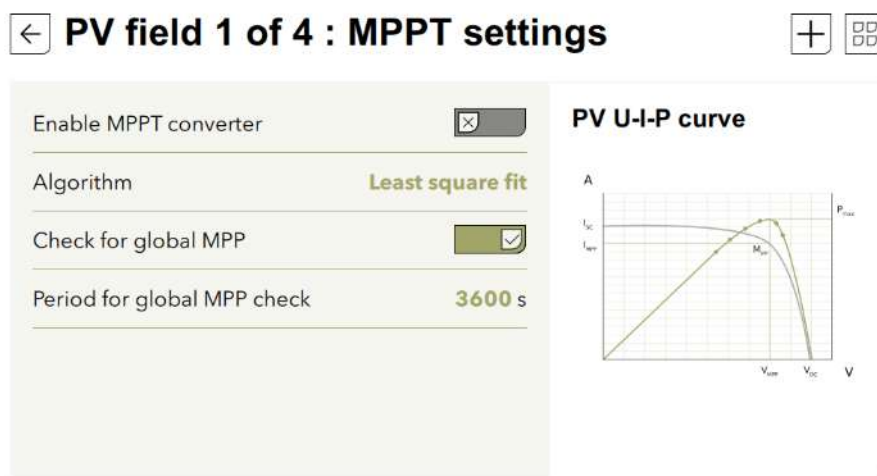

The settings are:

- **Enable MPPT converter:** this stops the operation of the mppt entry. Beware that it is not all the solar but only one entry. If you are on the MPPT2 screen, only the MPPT2 will stop/start. The inverter function is not affected by this setting. If one mppt entry is not used disable it otherwise a warning message will be given after 48h without production.
- **Algorithm Selection:**
 - LSF: A standard Perturb and Observe algorithm, optimised with a least square fit to find the exact voltage of the mpp for best efficiency.
 - Period for global MPP check: interval of time between scan of the full pv curve to detect the max
 - Fixed Voltage set point: this is very useful for special applications like working on a lab voltage source for tests or others.
 - OC voltage ratio: regularly the open circuit voltage is checked and the converter operate at a fixed voltage corresponding to a ratio of this measurement. For example, 500Voc is measured then the converter will operate at 400V with a 0.8 ratio.
- **Check for global MPP:** every hour, a scan of the PV curve is performed to detect local maxima.

PV U-I-P curve

Current

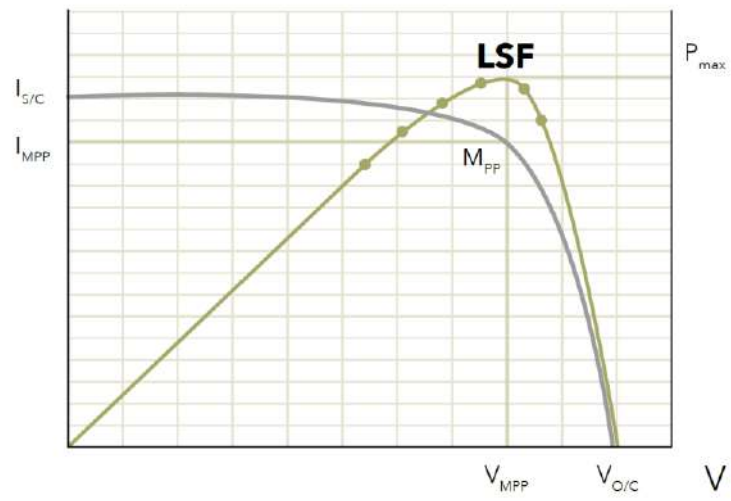

5.5 Battery

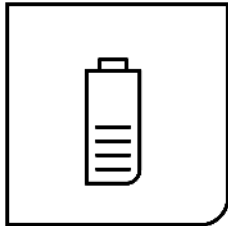

5.5.1 General information

The next3 is a fully automatic charger designed to guarantee an optimum charge for the most used battery types: lead (liquid acid, gel or AGM), and Lithium among others. The next3 charger will use the energy either from solar or from the grid/genset. The choice of the battery type is done during the wizard at commissioning and cannot be changed during operation.

Standard lead batteries with liquid (VLA, VRLA), gelled (GEL) and AGM electrolyte may be used. The next3 can easily be configured to adapt the charging profile (bulk, absorption, equalization, floating) and voltages to the battery type connected. Other battery types as Ni-Cd, NiFe, Vanadium, Aquion, etc. can also be used as the configuration possibilities for voltage levels and currents are very flexible.

The next3 can be connected to lithium Battery Management System (BMS) with CAN bus if the protocols of communication are compatible. In that case the BMS decides the voltage levels and currents that are optimal for the battery and communicates this information to the next3 system. The solar battery charger enters automatically into operation as soon as the solar irradiation is sufficient, and PV modules produce enough voltage (200V start-up voltage). The charging from the grid/genset is performed according to the AC energy management settings. When charging from the grid/genset, the next3 follows the same charging cycle as the solar. The maximum charge current of the battery will limit both the charging with solar and with the grid. The solar has the priority, and the power coming from AC source is decreased first.

The next3 configuration can be modified by the user or the installer to adapt the equipment to the chosen battery in the best possible way. These parameters can be modified by means of the remote control nx-interface.



The use of other battery types like NiFe, Ni-Cd, non-communicating Li-ion or others is possible if the charge profile is properly programmed, in accordance with the specifications of the battery manufacturer, in agreement with the battery manufacturer and under the responsibility of the installer.

5.5.2 Battery Information

Much information can be obtained from the next3 about the battery state and the inverters operation. The information can be seen on the remote control nx-interface, on the web portal and the APP (if connected to internet for monitoring), or with a dedicated communication (MODBUS TCP or RTU).

See chapter "6 HMI: Use of nx-interface" to have the map of all screens.

The information screen seen on the nx-interface for the battery is as below:

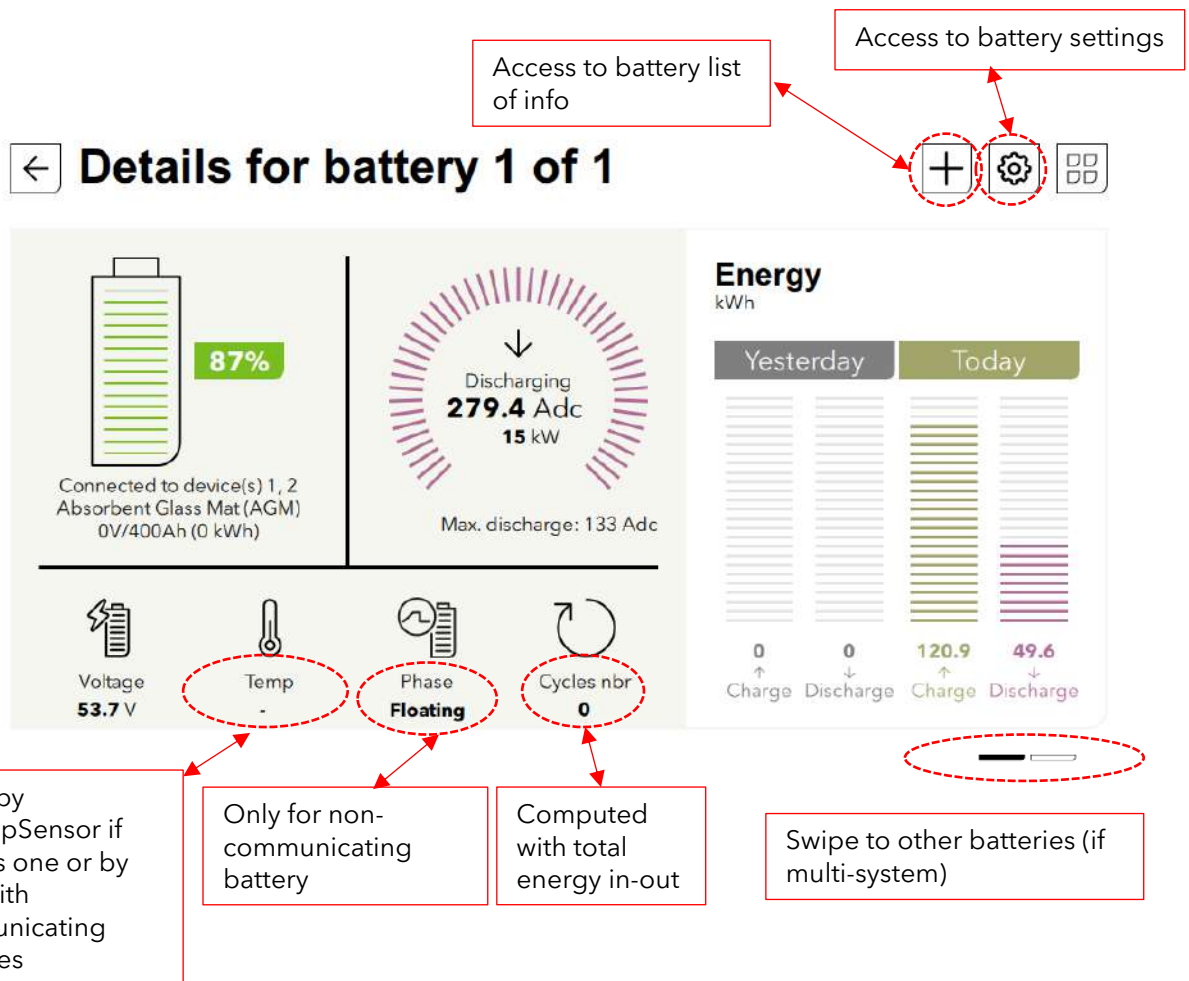

For multiple batteries, each can be seen independently with a left/right swipe.

Comments about the basic information displayed on the nx-interface:

- When connected to a communicating lithium battery BMS, info is given by the BMS.
- The day charged and discharged energy (**Today**) are calculated from midnight to the actual time. The energy of previous day (**Yesterday**) is computed from 00:00 to 24:00 the previous day.
- The **Temperature** is given only if there is a measurement, else "--" is displayed and the temperature compensations are not used. The temperature can come from the nx-tempSensor or send by the battery BMS through communication. When both are available the BMS data is used in priority. However the second sensor measurement is also logged and can be found in datalogs.
- The power and current shown in this display is correct only if there are only next3 compatible devices in the system.
- The % **SOC** can only be accurate with exclusively next3 inverters connected to the battery in case of non-communicating battery. If other chargers or loads are directly connected to the battery, their energy consumption/production cannot be measured, so the current measurement will not be correct.

5.5.3 Battery Settings

The basic configuration is done with the wizard during commissioning. On the dedicated screens, the settings are organised with topics:

- **Battery General Setting:** type of battery (if it was a communicating battery, it cannot be changed on the fly), max charging current
- **Battery Cycle:** Parameters defining the charging profile (when it is not a communicating battery).
- **Battery Protection:** Parameters that defines how the battery is protected: for example, when to stop the inverter (when it is not a communicating battery).

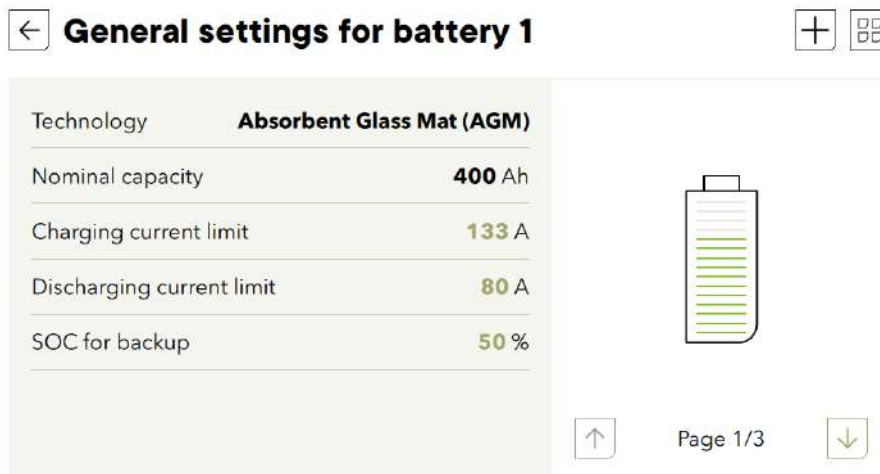

For the lithium batteries with BMS, this first screen is a little bit different, as the charge/discharge current limits are given by the BMS. Then if the user wants to have other current limits, he must activate the manual limits. Notes that the maximal currents given by the BMS are always respected first.

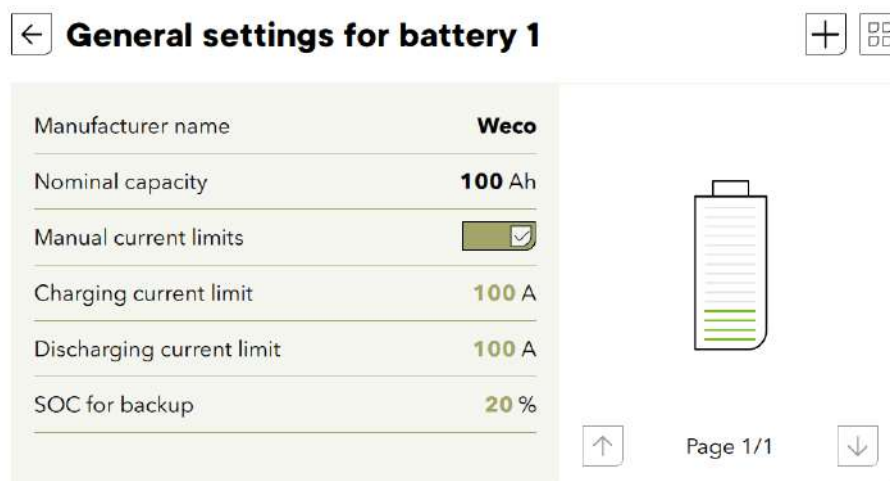

The battery cycle settings are useful and shown only for non-communicating batteries.

← **Cycle settings for battery 1** +

Floating voltage	53.6 V
Absorption	<input checked="" type="checkbox"/>
Absorption voltage	57.2 V
Equalization	<input checked="" type="checkbox"/>
Equalization voltage	63.2 V

Voltage
V

Time

Page 2/3

Advanced settings (durations, intervals, reduced floating, ...) can be accessed with the + sign.

← **Under/over-voltage settings for battery 1** +

Undervoltage at rest	46.32 V
Undervoltage duration before error	3 min
BLO reset voltage	52.8 V
BLO	<input checked="" type="checkbox"/>
Overvoltage	67.92 V

Page 3/3

The B.L.O (Battery Life Optimizer) is a special algorithm that saves the lead-acid battery life. A battery permanently operating at low state of charge sees its lifetime drastically reduced. To force the user to recharge the battery, the undervoltage threshold is increased with each disconnection, and returns to its original value if the battery has been recharged up to a certain voltage. For this reason, the user will not be able to constantly discharge the battery without at least having recharged it.



A similar system is available for communicating batterie: the adaptative SOC.

5.5.4 Battery: additional explanations

5.5.4.1 Energy management of the battery

The energy management of the battery is performed with the "SOC for backup" mainly. In the advanced setting the "SOC for gridfeeding" is also available.

The default values are 100% for SOC for gridfeeding, 20% for SOC for backup with lithium and 50% soc for backup with lead acid batteries.

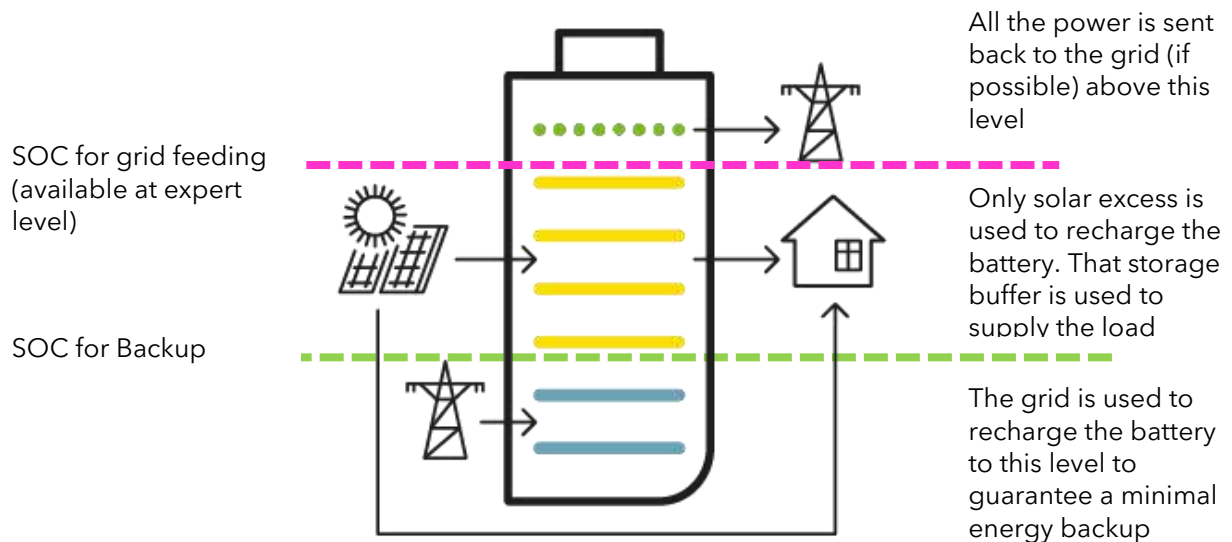

5.5.4.2 Comments about the State Of Charge (SOC) for backup

If the SOC for backup is set to 100%, the battery will be fully charged with the AC-source (when available) with a target voltage following the cycle (for lead acid: absorption, floating, ...) or with the voltage given by the BMS.

If the next3/1 is in Smart-Boost due to a max current limit on the AC-source, the battery can be discharged below the SOC for backup and down to the SOC for end of discharge.

If the SOC for backup is lower than 100% the charging may stop before reaching the target voltage of the cycle (for lead acid). Voltage limits of the battery cycles are always used as boundaries in any case.

SOC for backup is modified in the battery configuration menu and is available to basic user. It is possible to change it at any time.

5.5.4.3 Comments about the State Of Charge (SOC) for grid feeding

The principle of the SOC for grid feeding is that if the SOC is higher than this threshold, the battery is discharged in the grid (if grid available and grid feeding allowed). After some time, the SOC will be at the setting value and there will be no grid feeding from the battery anymore.

The SOC for grid feeding can be used for

Buffering peak solar production when grid feeding power is limited.

Discharging the battery voluntarily for tests by a manual change of the parameter.

Keep the battery at a lower SOC than 100% without losing the energy production

If the SOC for grid feeding is 100%, the battery voltage is maintained at the target voltage of the cycle (for example absorption voltage).

When discharging the battery, the low boundary for voltage will be limited to undervoltage level +2% higher. That means the battery will go down to the SOC you adjusted but keeping that minimum voltage to reduce the discharging current.

The SOC for grid feeding must be set higher than the SOC for backup.

5.5.4.4 Battery Cycle for lead acid battery

The next3 is a fully automatic solar and grid charger designed to guarantee an optimum charge for most type of batteries: lead/liquid acid, lead/gel, AGM batteries or Lithium. The battery charger enters automatically into operation as soon as the irradiation is sufficient, and the photovoltaic panel voltage is sufficient.

The charging from the grid/genset is performed according to the AC energy management settings.

When charging from the grid/genset, the next3 follows the same charging cycle as the solar.

The batteries can be fully charged by the successive phases 1 to 4 described hereunder:

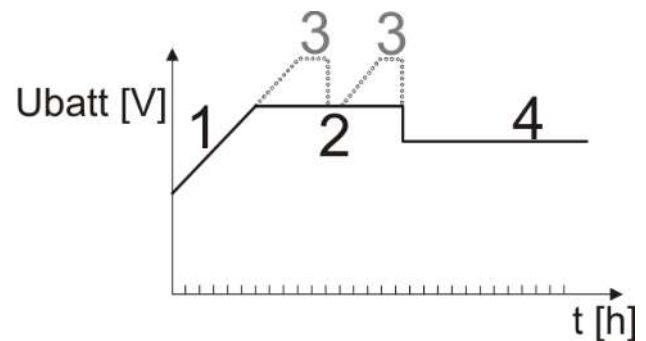

Bulk phase

The bulk phase is the stage where the next3 applies the maximum charging current (if there is enough energy available on solar and/or AC source) to charge the battery. This will lead to an increase of the battery voltage up to the next phase voltage limit; absorption, equalisation or floating, depending on the charging profile adjusted.

The bulk phase will allow a quick charge thanks to the high current. For lead batteries, this phase will charge them up to 90% SOC.

It is important that the maximum battery charge current is set according to the battery specifications to prevent damaging them. This current can be limited with the setting "Charging current limit". The maximum charging current might not be reached due to diverse conditions like the solar irradiation is not enough in an off-grid system, or the available power from AC source is too low, or the ambient temperature is creating a derating on the power electronic, etc...

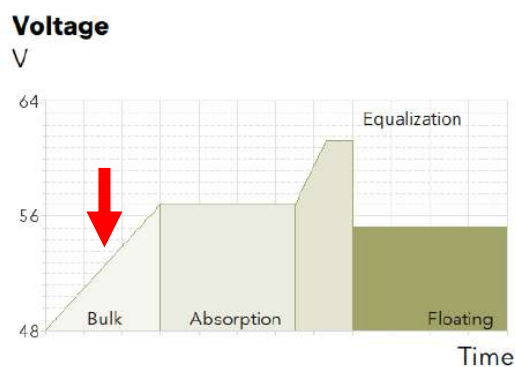

Absorption phase

This constant voltage phase, mainly used in lead batteries, allow to charge the last percents of the batteries. Because of keeping the voltage stable and the battery accepting less and less energy, the charging current will diminish progressively.

It can be ended by time (if there is enough energy to keep the phase for longer periods) or by current (if the battery ends his charge before the adjusted time)

Be aware that due to the current reduction during the phase, the power required to charge the battery will also be reduced. This can cause a reduction of the PV production if the excess energy is not used for other purposes than for charging the battery.

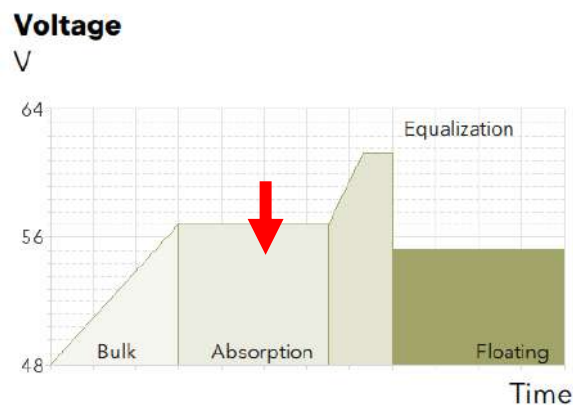

Floating phase

When the battery is charged, a constant voltage is applied to the battery to keep it full and compensate his self-discharge.

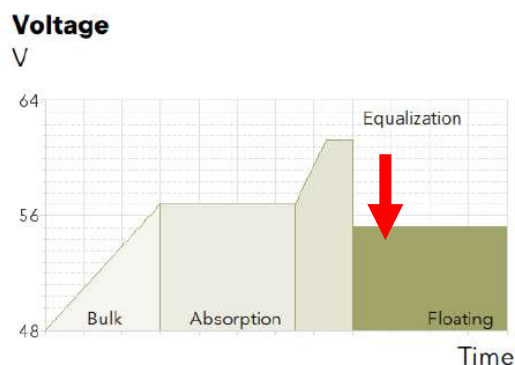

Equalization phase

Some types of battery need equalization in order to avoid the stratification of the water and acid they contain.

This phase is allowed only for flooded/wet batteries with liquid electrolyte. During this phase, the charging voltage target is temporarily higher. It allows, on one hand, to equalize the electrolyte density (stratification control) and, on the other hand, to equalize the voltage among the cells in series/parallel of the battery bank. During this process, the charging current can be limited by parameter "equalization current".

By default, the equalization phase is forbidden because it is incompatible with gel and AGM

batteries and these are the most used batteries in the field. It can be activated/deactivated by the dedicated parameter in the battery cycle settings.

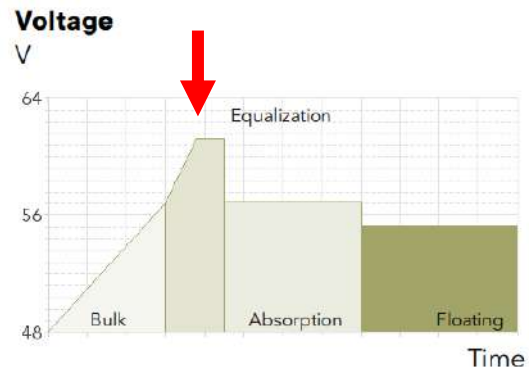
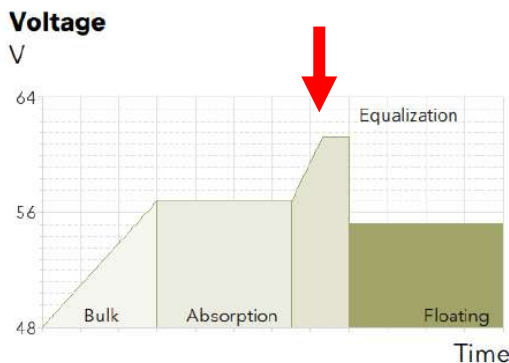

In a general manner, lead batteries charging profile consist of 3 to 4 phases while the lithium only need 2; bulk and floating.

When connected to a communicating lithium battery BMS, the charging profile is given by the BMS and cannot be adjusted in the next settings.

For more information, contact your battery supplier who will inform you on the values to be applied for his products.

	<p>Caution: the equalization of open liquid electrolyte batteries (vented) produces highly explosive and corrosive gas (hydrogen/oxygen). The battery room and/or compartment must be adequately ventilated.</p> <p>Be careful: this charging phase may bring the batteries to voltage levels that can damage sensitive loads connected to the battery DC bus. Check that the connected loads are compatible with the highest voltage levels possible taking into account any compensation of the temperature sensor.</p> <p>A too long or frequent equalization phase can lead to an excessive consumption of electrolyte, a premature ageing or destruction of the battery. Follow scrupulously the instructions and recommendations of your battery supplier.</p>
---	---

	<p>Caution: incorrect values which do not comply with the manufacturer's instructions can lead to a premature ageing and even the destruction of the batteries.</p>
---	---

5.5.4.5 Temperature compensation

For non-communicating battery (no BMS) with a nx-tempSensor, the voltage adjustment levels for charging the battery (absorption, equalization, floating...) are automatically corrected in real time according to the battery temperature.

The value of this compensation is given in V/°C for a reference temperature of 25°C by a parameter. Default value corresponds to -3mV/°C/cell which is -0.072V/°C for a 48V battery. For example at a temperature of 30°C, the voltage compensation is: $(30-25)*(-0.072) = -0.36V$. For a floating voltage value set to 54.4V, the effective floating voltage (compensated) will be 54.04V at 30°C.

Another example with 5°C, the compensation will be $(5-25)*(-0.072) = +1.44V$, so a floating voltage that goes from 54.4V to 55.84V.

5.5.4.6 SOC for end of discharge

To prevent a stop/disconnection of the battery by the BMS that would require a manual reset or that would definitely block the system, a SOC for end of discharged can be chosen. That way, the next3 stops to discharge the battery before the signal of the BMS and before the opening of the BMS contactors that would completely unpower the whole system. The next day, or when the grid/genset or the sun are back, it is possible to recharge the battery and recover.

An error is set if the SOC is lower than this value. The discharge of the battery is prohibited when the error is set but the charge is still allowed. The error is reset if the SOC is greater than or equal to the SOC for backup or if the bit "SOC for end of discharge" in the property: "Conditions for energy management" is not set.

By default, the function is deactivated for non-communicating batteries and activated with an initial value of 15% for communicating batteries.

5.5.4.7 Adaptive SOC for backup

The goal of this function is to prevent the battery to stay at a low state of charge during a long period of time and to avoid that the inverters are disabled due to an unwanted undervoltage. The lithium batteries are managed by the SOC given by the BMS of the battery manufacturer. One point recurrently observed in practice is that the SOC is not always accurate. It can drift and recalibrations are often done at 100% SOC when the BMS is sure that the battery is full. In practice, there are undervoltage problems when batteries are cycled at low SOC without reaching 100% regularly. That may be the case per example in self-consumption systems during the winter when the solar production is low.

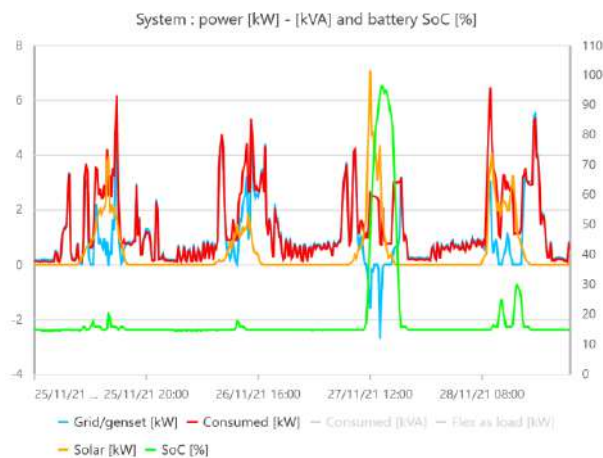

To cope with this problematic situation, an advanced adaptive algorithm has been developed.

The adaptive SOC function is enabled/disable in the advanced battery menu with « Adaptive SOC for backup » (Y/N). If the function is enabled, the adaptive SOC for backup is:

- increased every day if the SOC has been < «SOC to increase adaptive SOC for backup » during the day. The increase step is set via the value: « Adaptive SOC for backup slope ». The slope is given in %/day; per example 5% per day is the default value.
- reset to its initial value: « SOC for backup » if the SOC is reaching more than « SOC to reset adaptive SOC for backup » for more than « Time before resetting adaptive SOC for backup ». This value is used to set a minimum waiting time with a fully charged battery before resetting the adaptive SOC for backup. Typically, 5minutes (300 seconds) at 99%.
- The adaptive SOC for backup pushes the « SOC for gridfeeding » and the « SOC for end of charge » upward for proper operation when it gets to the same level.
- The adaptive SOC is increased by a value « Adaptive SOC for backup undervoltage

increment» if a warning or an undervoltage error has been detected. This prevents to turn off the inverters due to a low battery voltage only because SOC calculation drifted.

The following graph illustrates the behaviour:

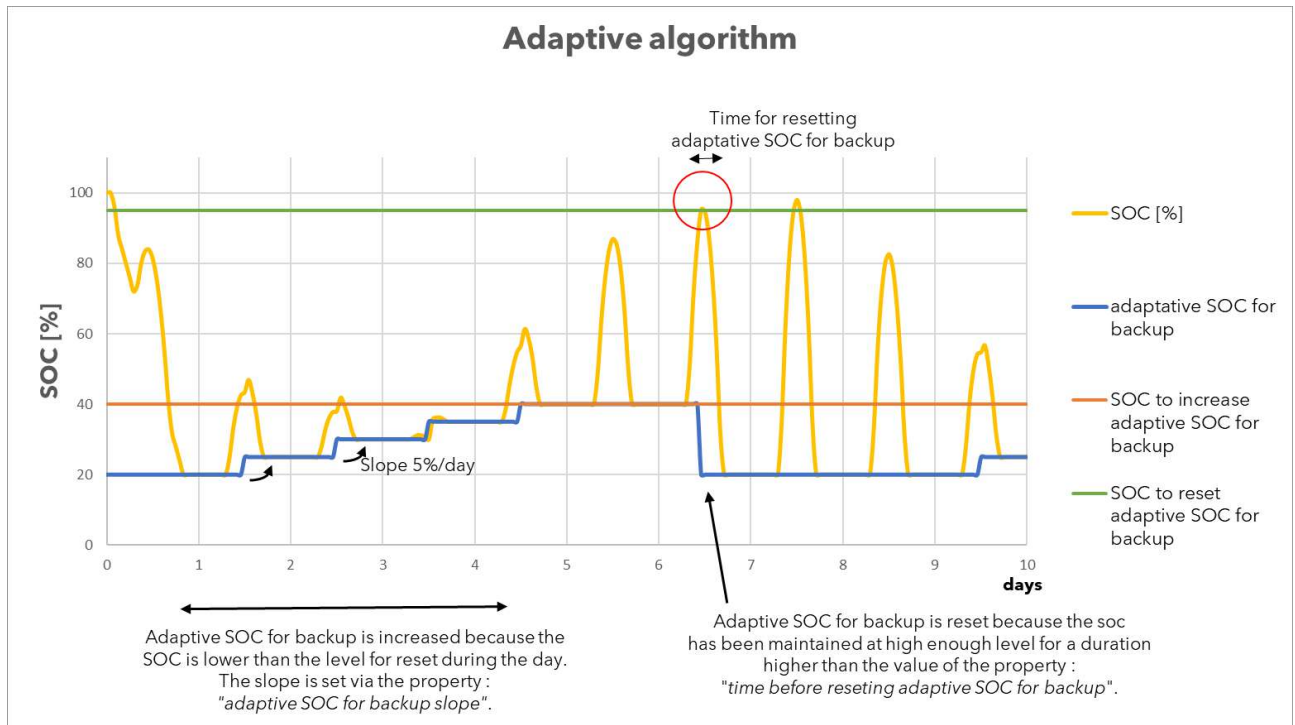

In those cases, with low solar production, the battery is anyway not getting full. There is then almost no loss of capacity for storage. It only optimizes the use and life of the battery by cycling it at a higher mean SOC.

The default values are:

- This function is implemented and activated by default.
- The adaptive SOC for backup starts at the same level as SOC for backup, it is 20% by default for lithium batteries and 50% for lead-acid.
- The SOC to increase adaptive SOC for backup is at 99% for non-communicating batteries and 98% for communicating batteries: that mean it can really force the battery to be fully recharged by default (and allows recalibration of the battery by the BMS).
- The SOC to reset adaptive SOC is at 99.9% for non-communicating batteries and 98.9% for communicating batteries. If you modify this parameter, take care that some BMS stay at 99% for a long time.
- The time before resetting adaptative SOC for backup is 5 minutes (300 seconds).
- The slope of increase is 5% per day.
- The SOC for grid-feeding is at 100%, if it is lower than the SOC to reset adaptive SOC, this one can never be reached and the adaptive SOC for backup increases all the way.
- The last 2% charge of adaptative SOC is done with solar only, to be sure the sun is back.

	<p>The default values were chosen to fit in most situations with the different brands of batteries tested.</p> <p>Be careful not to mix those levels with the SOC for gridfeeding and SOC for end of charge. Improper settings will cause bad behavior of the system.</p> <p>Always respect the following order:</p> <p>SOC for end of charge \geq SOC for gridfeeding \geq SOC to reset adaptive SOC \geq SOC to increase adaptive SOC for backup.</p>
---	--

5.5.4.8 Periodical recharge and discharge

There are possibilities to perform regularly full recharge or discharge of the battery to improve its life.

For batteries that have a limited end of charge level (per example 90%) there is always the risk that the calibration of 100% SOC is not performed properly by the battery BMS. In that case a periodical recharge to 100% is a good option.

Some batteries that are always in floating mode should be sometimes cycled. In that case a periodical discharge is a good option.

A setting « *Periodical charge and discharge* » can be activated deactivated and associated settings adjusted:

- *Periodical charge and discharge* (used to enable or disable the function): true by default.
- Delay before periodical charge: set to 7days by default.
- Delay before periodical discharge: set to 3months by default.
- Time before resetting periodical charge or discharge: set to 10min by default.
- Periodical charge SOC: set to 100% by default. If the user reduces the soc for grid feeding value, periodical charge will be automatically enabled.
- Periodical discharge SOC: set to 100% by default. 100% ensures that no periodical discharge will be done automatically.
- Use AC source during periodical charge or discharge: default value: yes for backup application and no for standard application. This ensures a fast periodical discharge following by a fast charge in backup application and ensures a periodical charge with solar power and a discharge in the loads in other applications.

←

Settings list for battery 1 of 1

☰

Periodical charge and discharge	<input checked="" type="checkbox"/>	ID 1.1.2.72
Delay before periodical charge	604800 s	ID 1.1.2.73
Delay before periodical discharge	7776000 s	ID 1.1.2.98
Periodical charge SOC	100 %	ID 1.1.2.95
Periodical discharge SOC	100 %	ID 1.1.2.96
Time before resetting periodical (d...	600 s	ID 1.1.2.74
Use AC source during periodical (...)	Show	ID 1.1.2.97

Note that it's also possible to combine both functions. For example, a backup application could have a soc for grid feeding at 80% with a periodical full charge each 7days and a periodical discharge down to 60% each 3months.

Example of periodical charge and discharge in test application:

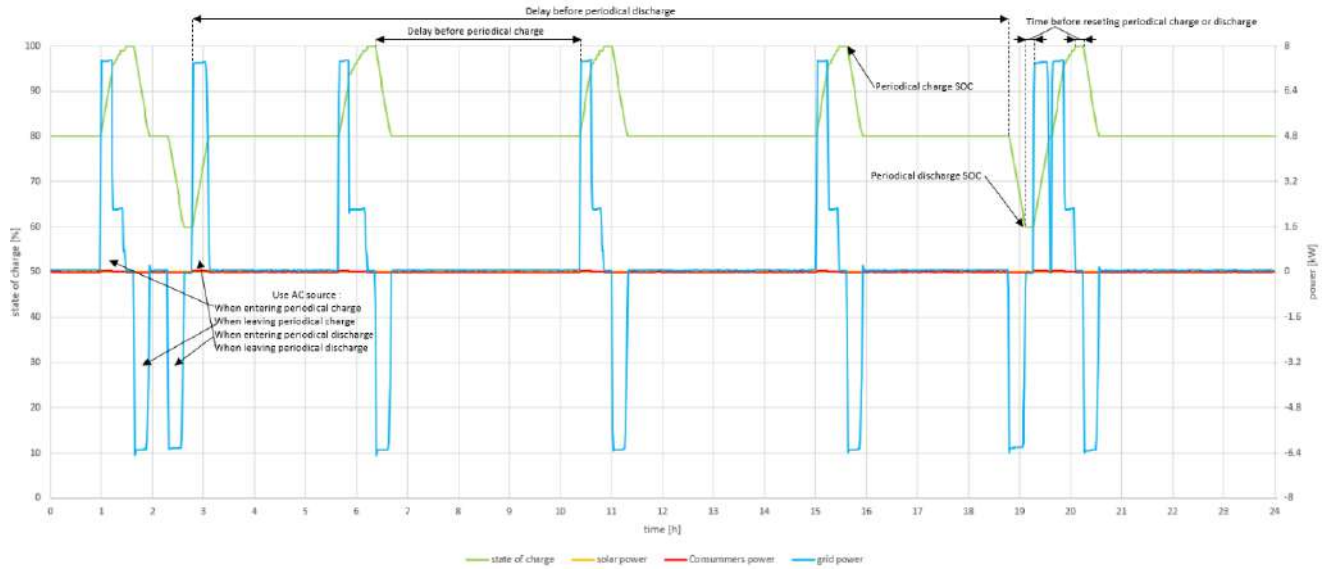

Example of a periodical charge without using the grid when entering and leaving periodical charge on a real house:



In that case the time since the last full charge at 100% is counted. If the time reach « *Waiting Time Between Periodical Full Charge* », then the level of « *SOC for grid feeding* » and a « *SOC for end of charge* » are set temporary to 100%. The forcing is released after « *Time Fully Charged Before Resetting Periodical Full Charge* » spent at 100%.

5.5.4.9 Maximal current with lithium batteries

The BMS sends the maximal current limits accepted by the battery. In practice, Studer observed that the reaction of the BMS when going to the limits differs from one BMS to another. Some stops immediately, some have a tolerance to go up to that level and work at that limit. That is why a margin factor of 0.8 is used by default to work in all cases. Per example if the BMS says 200A max charging, then the next3 will go up to $200 \cdot 0.8 = 160A$. This margin factor can be increase up to 1.

Manual current limits	<input type="checkbox"/>	ID 1.1.2.24
Discharging current limit	100 A	ID 1.1.2.25
Charging current limit	100 A	ID 1.1.2.26
Ignore BMS recommended currents	<input type="checkbox"/>	ID 1.1.2.84
Current limits marging factor	0.8	ID 1.1.2.27

Manual current limits can be given. They must be lower than the maximal current of the BMS that is respected in any case.

5.5.4.10 Energy management by voltage

The standard energy management is done with the SOC. In expert mode, it is possible to add voltage limits to manage the battery. This can help with special types of batteries, with non-communicating batteries or are securities for batteries with inaccurate SOC calculation by the BMS.

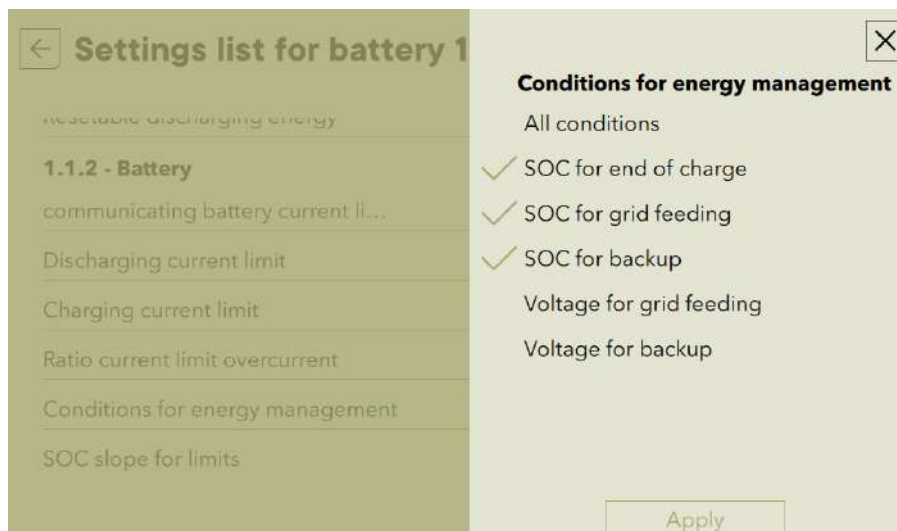

The voltages are given by the settings situated a little bit lower in the list:

Voltage for grid feeding	54 V	ID 1.1.2.39
Voltage for backup	48 V	ID 1.1.2.40

Note that the undervoltage level and max charging voltage level sent by the BMS of the battery or set by setting are always respected.

5.5.4.11 Recover from a low battery

When an undervoltage happens, the inverter stops. In order not to stay blocked in that situation, a button "clear error" will appear on the synoptic screen. When used, it leaves the system to restart temporarily and per example recharge from the grid or from a generator. The "clear error" function is also performed with a short press on the front face button of the next3.

In case of undervoltage, the inverter function is disabled but not the solar. The next morning when the sun comes back the next3 will automatically restart.

5.5.4.12 External management of the battery with external contact

It is possible to modify the behavior of the next to the battery in function of the command entry entry (dry contact input, see chapter 4.7.2)

← Settings list for battery 1 of 1 ☰

Limits level	Limits medium pri...	ID 1.1.2.47
Setpoints level	Setpoints high pri...	ID 1.1.2.48
Command entry index	1	ID 1.1.2.77
Command entry function	Reduce charging c...	ID 1.1.2.103
Value used when command entry ...	0	ID 1.1.2.104
BMS communication loss timeout	5 s	ID 1.1.2.89
Abnormal voltage level	4 V	ID 1.1.2.106
Abnormal temperature level	5 °C	ID 1.1.2.107

The available settings are :

- Select the Command entry index.
- Select the desired Command entry function:
 - Charge current limit reduction
 - Reduce discharge current limit
 - Modification of the SOC for end of charge
 - Modification of the SOC for grid feeding
 - Modification of SOC for grid backup
 - Modification of SOC for end of discharge
 - Modification of voltage for grid feeding
 - Modification of voltage for backup
- Select the value associated with the chosen function (Value used when command entry is activated)

The default values are :

- No command entry is selected (value 0 for Command entry index)
The function is: Load current limit reduction

The associated value is 0A.

Per example to charge the battery to 100% only during the afternoon, have it at 50%, but change it to 100%:

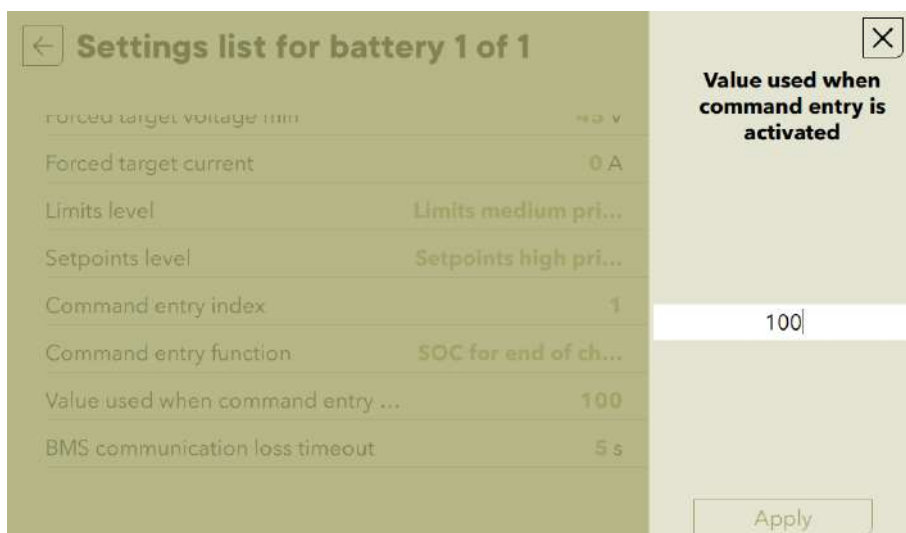
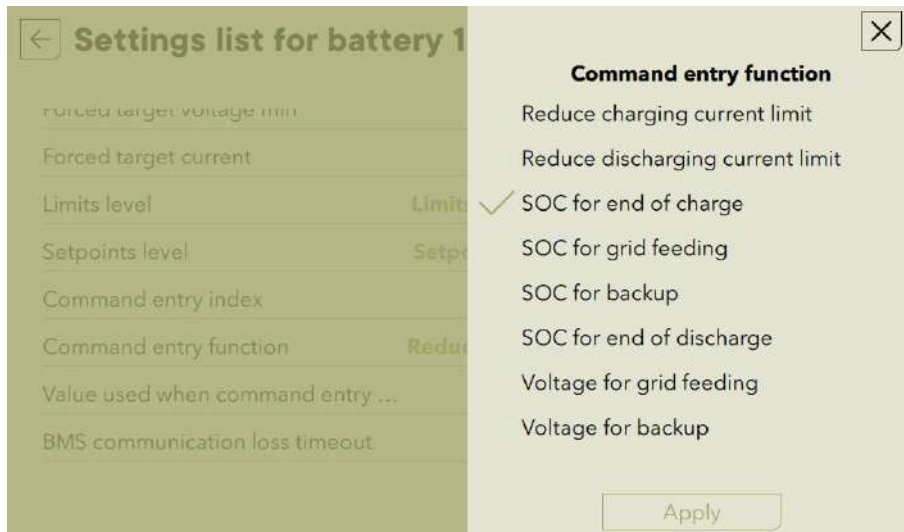

And control the time with the AUX relay connected to the CMD entry.

5.6 AC-Loads



5.6.1 General information

The AC-Loads is where the user electrical consumptions are connected.

The output voltage is 230V phase to neutral and 400V phase to phase in standard three phased configuration (default). The frequency is fixed at the nominal frequency of 50Hz for the NX3 by default.

The AC-loads are monitored and recorded in the datalog.

AC-coupling of grid inverters on the inverter Loads side is only permitted with restrictions. See the special application chapter for details about it.

5.6.2 AC-Loads Information

The general information on output is seen on the synoptic:

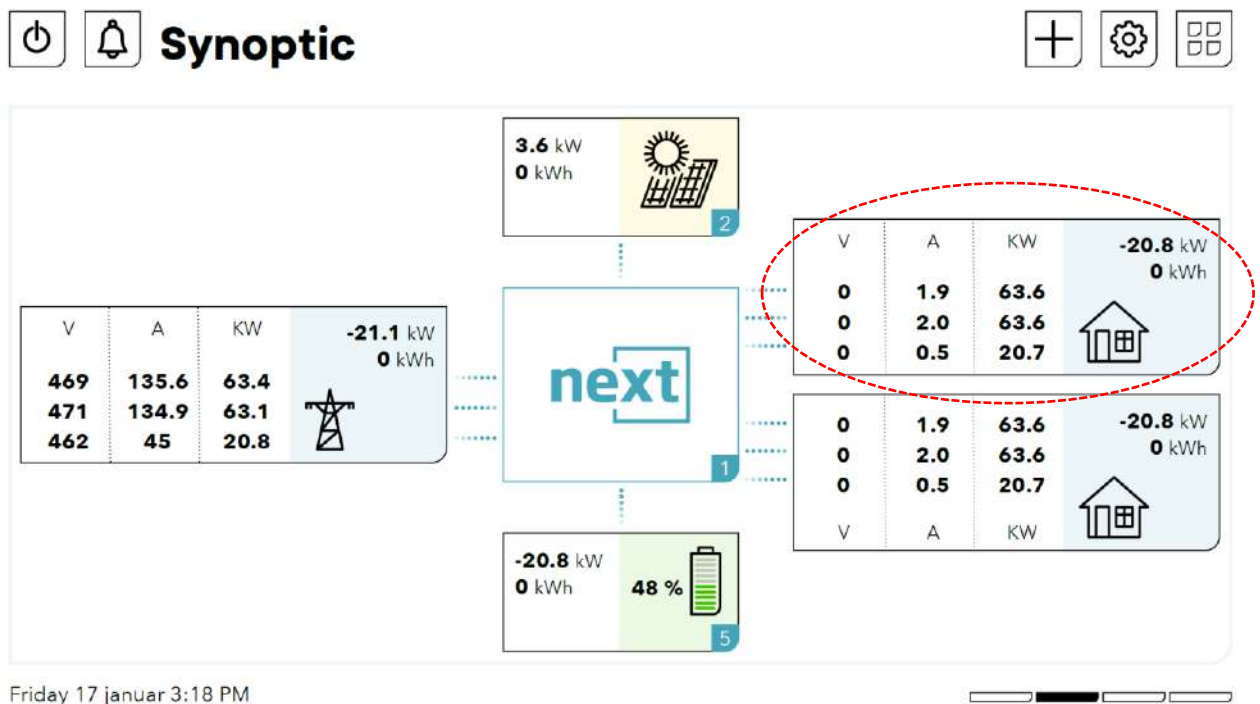

Clicking on the component AC-loads give you access to the level 2 and see the details about AC-loads.

← Details for AC-Loads + ⚙️ 🗃️

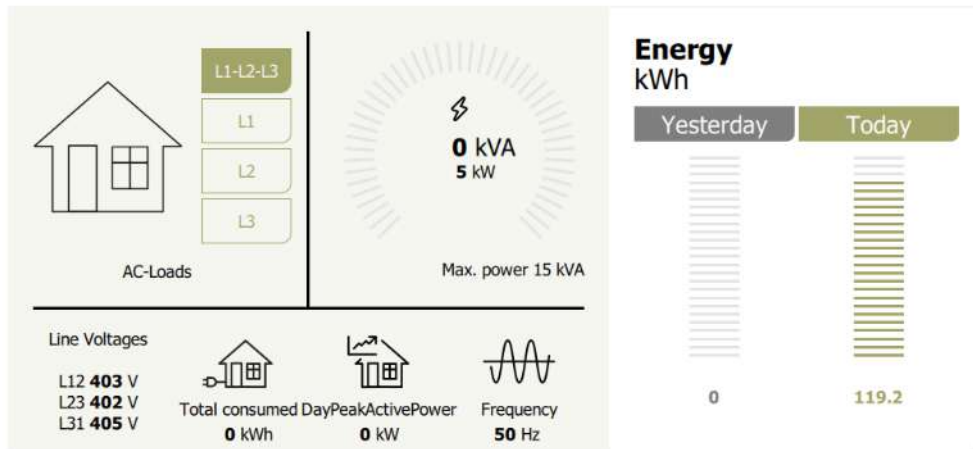

Details of each phase are available by clicking on the phase buttons:

← Details for AC-Loads (L2) + ⚙️ 🗃️

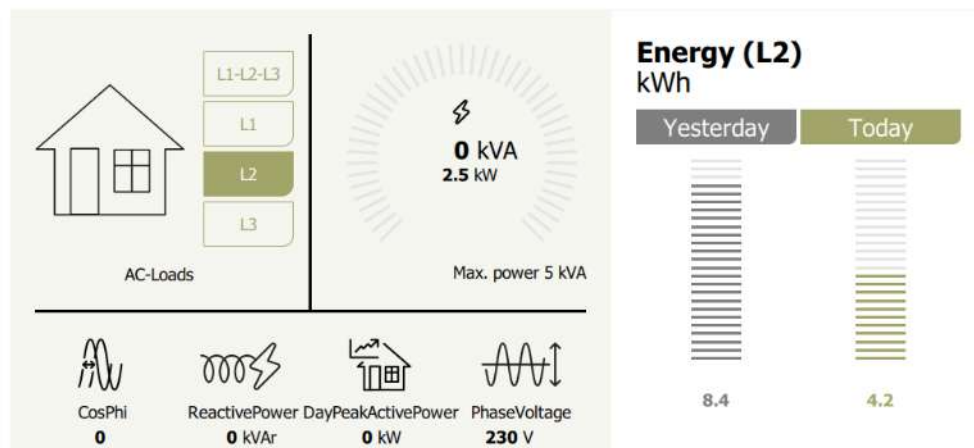

5.6.3 AC-Loads settings

There is nothing to set in the wizard for the AC-loads.

In basic level, the available settings are:

- ON/OFF of the inverter function only. It will deactivate the inverter mode (DC to AC converter) and still allow the solar to work. Use this setting for the wintertime for example, when you want the solar to continue to charge the battery but stop to power supply the loads.
By deactivating this function, all the modes will be switched on/off at the same time.
- Behaviour In overload:
 - Number of restart attempts
- Standby: to spare energy, the inverter will deliver a voltage pulse once per second. This allows to detect if there is a load connected and reactivate the inverter if it is the case. The sensitivity of load detection can be set from 0.1% of the nominal power (15W) up to 1% (150W).

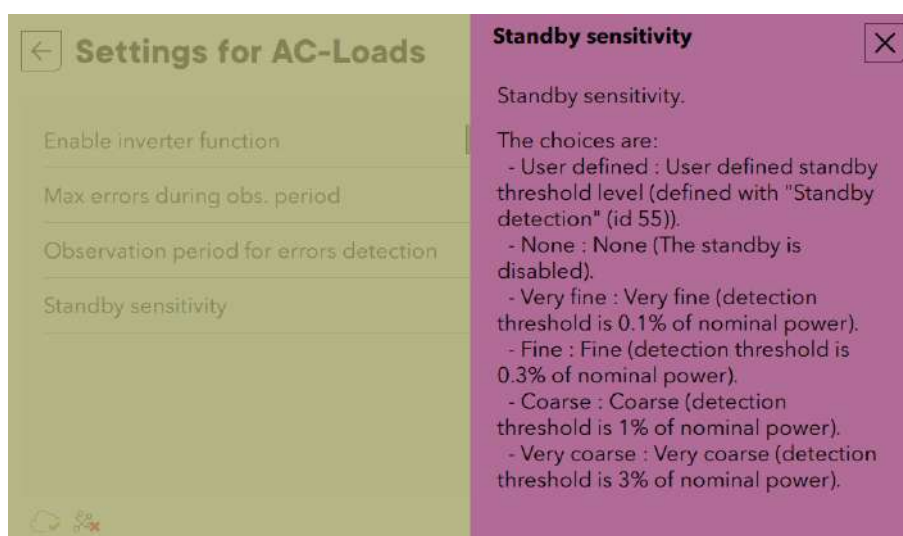
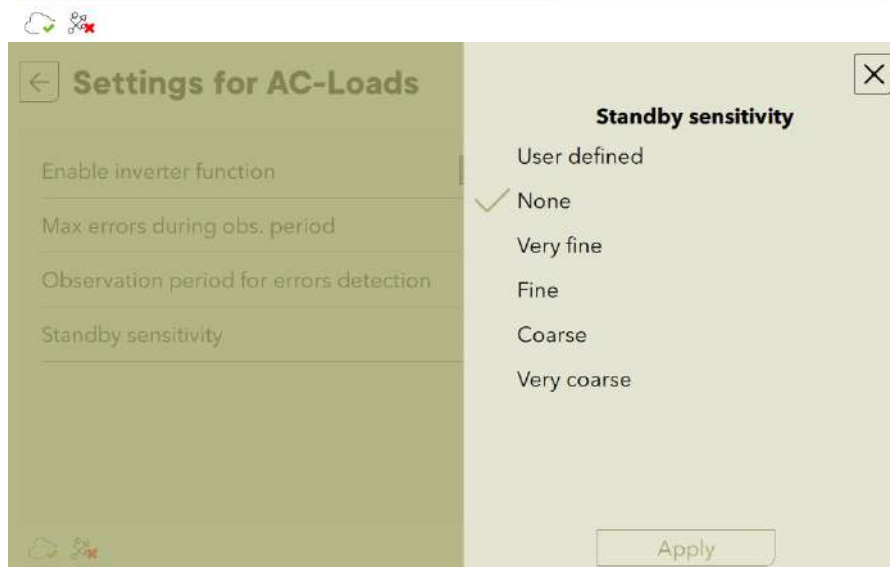
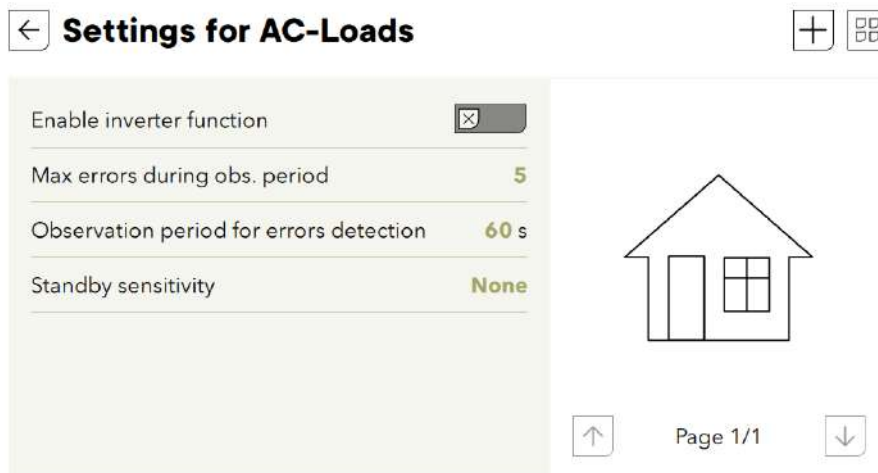

Notable parameter is the one about AC-coupling to accept a backfeeding of power on that port. In case of AC-coupling with standard grid inverter, the best is to program it during the wizard. See the AC-coupling chapter in the Special application section of this manual.

5.7 AC-Flex



5.7.1 General information

The next3 has an AC connection that can be freely programmed as:

- A second AC-Source, for example for
 - Grid /genset in hybrid installations with grid and a generator backup that don't require grid connections securities.
 - Gensets of different sizes for fuel consumption optimisation
 - Shore connection/onboard generator for boats
- A second AC-Loads, for example for
 - load shedding, non-priority loads, dump loads, etc.
 - load monitoring

The choice of configuration is done at the system set up with the configuration wizard. The AC-Flex behaviour is fixed and cannot be changed during operation for security reasons. To change the configuration, you will need the expert access code and to run the wizard again (restart the settings).

5.7.2 AC-Flex as source: information and settings

The information display for the AC-Flex as a source is like the AC-source when you select a genset, as shown below.

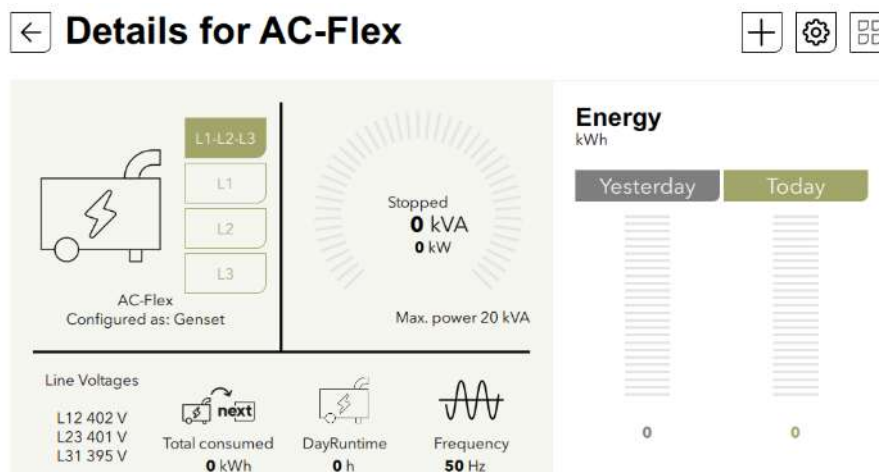

The settings for the AC-flex as a source are the same as for the standard AC Source. It is exactly similar for the genset connected on the AC source, so it is not repeated here (see AC-source settings chapter 5.3.3).

5.7.3 AC-Flex as Loads: information

The information display for the AC Flex as load is like the standard AC-loads, as shown below.

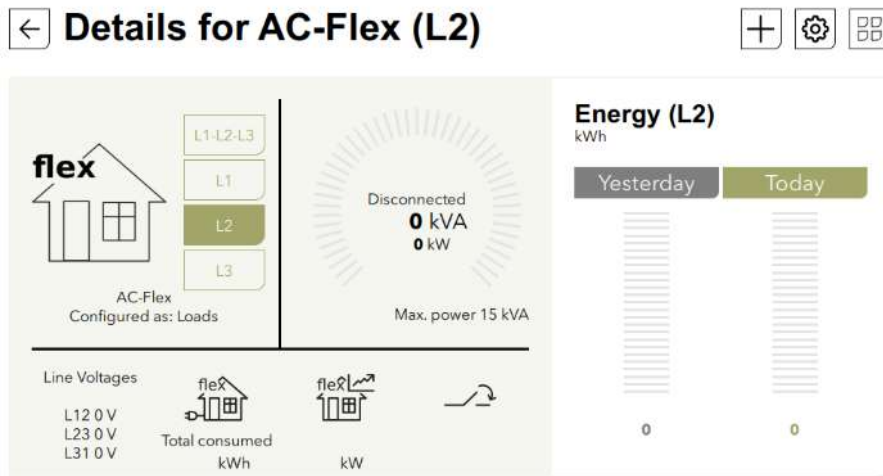

5.7.4 AC-Flex as load: Settings

The main choice for the ac-flex being an AC-source entry or an AC load output is done during the commissioning with the wizard. There is no possibility to change this again live without stopping all the systems.

The 3 AC-Flex load contacts of each phase of one device can be programmed independently to open and close under various conditions. The contact corresponding to the neutral is automatically switched on when at least one phase is activated.

The programming is organised at the level 2 with a simplified menu (level 3) proposing the choice between Modes:

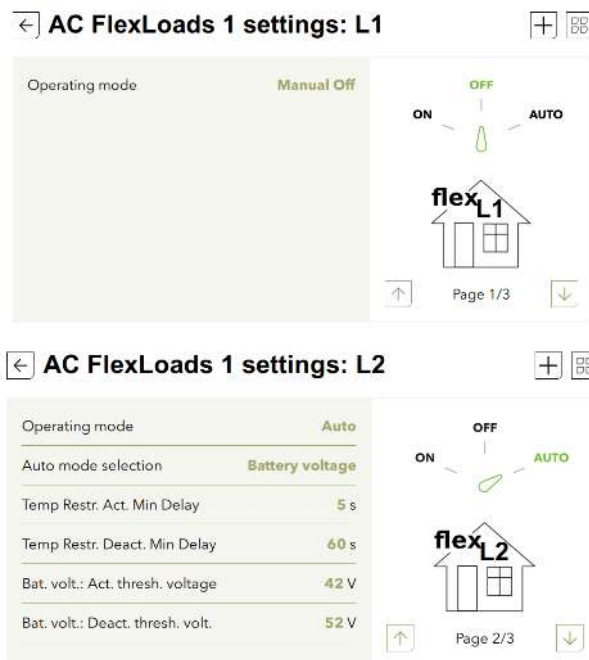

Manual OFF: always deactivated, in position NO. This is also the unpowered state.

Manual ON: always activated, in position NC

AUTO: some activation/deactivations conditions are used. This can be chosen in a list of simple use pre-set cases (one is selectable at a time)

- **Battery voltage:** An hysteresis is used to activate relay when battery voltage reaches threshold activation voltage and deactivate relay when threshold deactivation voltage is reached. Used for example for load shedding when the battery gets empty.
- **Battery SOC :** An hysteresis is used to activate relay when battery SOC reaches threshold activation SOC and deactivate relay when threshold deactivation SOC is reached. Used for example for a genset start on battery state of charge or a load shedding when the battery is empty.
- **Battery temperature:** for example to start a heater when the battery temperature is too low to avoid freezing.
- **Battery charge phase:** for example to run a fan in equalization for open lead acid battery.
- **Power AC :** This is used for load shedding, when there is too much load, the relay is activated

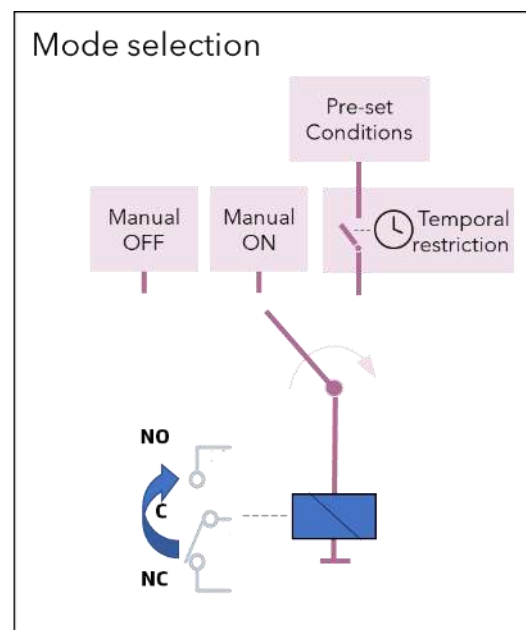

until the power is reduced under another level.

- **Solar excess OnGrid:** activated when power is fed to the grid over a given level. This can be used for example to switch on loads for self-consumption optimisation. The hysteresis and delay allow to optimize the switching the load (avoid turn on and off repeatedly).
- **Solar excess:** activated when at least one solar converter in the system is power limited. the battery is full and there is unused solar. This is used in order to optimize the use of solar in offgrid or grid-feeding not allowed.
- **Scheduled time:** chose a time frame during the day to activate the contact.
- **On-source:** This is used for example to connect some loads when connected to an AC-source if you don't want to have them running on the batteries.
- **Off-source:** relay is activated when inverter is operating offgrid.
- **Cmd entry:** The relay is closed in association with a command entry.
- **Error/Warning:** relay is activated when there is an alarm in the system.

The detailed levels are chosen by default to fit in most situations, we then advice to only activate one function without changing detailed parameters.

Most of the above pre-set signals can be temporally processed using a temporal restriction.

5.7.4.1 Battery voltage

Activation and deactivation of the AC-Flex load contact in function of the battery voltage. The parameters to setup this function are:

Activation threshold voltage [V]	If the battery voltage exceeds this value, the relay is activated.
Deactivation threshold voltage [V]	If the battery voltage exceeds this value, the relay is deactivated.

These 2 values are the boundaries of a hysteresis function.

5.7.4.2 Battery SOC

Activation and deactivation of the AC-Flex load contact in function of the state of charge of the battery connected to the device. The parameters to setup this function are:

Activation threshold SOC [%]	If the battery SOC exceeds this value, the relay is activated.
Deactivation threshold SOC [%]	If the battery SOC exceeds this value, the relay is deactivated.

These 2 values are the boundaries of a hysteresis function.

5.7.4.3 Battery temperature

Activation and deactivation of the AC-Flex load contact in function of the temperature of the battery connected to the device. The parameters to setup this function are:

Activation threshold temperature [°C]	If the battery temperature exceeds this value, the relay is activated.
Deactivation threshold temperature [°C]	If the battery temperature exceeds this value, the relay is deactivated.

These 2 values are the boundaries of a hysteresis function.

5.7.4.4 Battery charging state

AC-Flex load relay is energized when the current battery charging state corresponds to one of the selected states in the following list:

- None
- Bulk

- Reduced Floating
- Floating
- Periodical Absorption
- Absorption
- Equalization

Multiple states can be selected.

5.7.4.5 Power AC

Activation and deactivation of the AC-Flex load contact in function of the active power of a selected AC terminal. The parameters to setup this function are:

Power selection	<p>Selection of the active power in the system used for AC-Flex load relay control:</p> <ul style="list-style-type: none"> • AcSource All • AcSource L1 • AcSource L2 • AcSource L3 • AcFlex Source All • AcFlex Source L1 • AcFlex Source L2 • AcFlex Source L3 • AcFlex Load All • AcFlex Load L1 • AcFlex Load L2 • AcFlex Load L3 • AcLoad All • AcLoad L1 • AcLoad L2 • AcLoad L3
Activation threshold Power [W]	If the measured active power exceeds this value, the relay is activated.
Deactivation threshold Power [W]	If the measured active power exceeds this value, the relay is deactivated.

The 2 threshold values are the boundaries of a hysteresis function.

5.7.4.6 Solar power

Activation and deactivation of the AC-Flex load contact in function of the produced solar power.

5.7.4.7 On-source

Activates the relay when inverter is connected to a source (AC-Source). Typically used when extra loads require to be connected only with external source.

This is used to connect the grid inverter in simplified AC-coupling mode.

5.7.4.8 Off-source

Activates the relay when inverter is on and not connected to a source (off-grid). Typically used to activate specific loads when inverter is operating off-grid.

5.7.4.9 Solar excess on-grid

Activation and deactivation of the AC-Flex load contact in function of the injected power into the grid. The Solar excess on-grid pre-set is typically used for self-consumption. To limit the feed power into the grid, loads are activated using AC-Flex load relays. The parameters to setup this function are:

Activation threshold Power [W]	If the measured total active power injected into the source exceeds this value, the relay is activated.
Deactivation threshold Power [W]	If the measured total active power injected into the source exceeds this value, the relay is deactivated.

These 2 values are the boundaries of a hysteresis function.

5.7.4.10 Solar excess

Activation of the AC-Flex load contact when at least one solar converter in the system is power limited. The Solar excess pre-set is typically used to add loads when there is an excess of solar

production. In order to prevent relay oscillations, it is important to set correctly the activation and deactivation delays.

5.7.4.11 Schedule time

The schedule time pre-set allows to activate and deactivate the AC-Flex load relay in a daily base. Restrictions can also be applied to avoid undesired activations. The parameters to setup this function are:

Starting date [secs from 01.01.1970]	Starting date of the scheduled daily activation-deactivation. Before this date, the relay is disabled.
Starting time [secs from midnight]	Time of the day at which the relay is activated
Ending time [secs from midnight]	Time of the day at which the relay is deactivated
Selected weekday	Allowed weekdays for relay activation.
Recurrence weeks	Allow the relay to be daily activated each given week. For example, with a value of 2 for this parameter, the relay will be disabled every two weeks.
Range of recurrence selection	Selection of the ending of the recurrences:
	<ul style="list-style-type: none"> • No end date: the daily activation-deactivation continue indefinitely. • End after occurrence • End date

5.7.4.12 Cmd-entry

AC-Flex load contact is controlled by a command entry available in the system. This entry is selected by entering its index number (available in CMD-IN settings). Any command entry in the system can be used to activate-deactivate the relay.

5.7.4.13 Errors and warnings

AC-Flex load relay is controlled according to the system alarms. Errors and/or warnings can be used to activate the relay. The following possibilities are available:

- Triggered by Errors
- Triggered by Warnings
- Triggered by errors and Warnings

5.7.4.14 Solar excess on-grid

Activation and deactivation of the AC-Flex load contact in function of the injected power into the grid.

5.7.4.15 AC-coupling

This setting is to connect/disconnect an grid inverter that would be connected to the Load side of the inverter.

The relays open during transition from on-grid to offgrid to immediately stop the grid inverter production. Then the frequency shift can make its job and regulate the solar-AC production.

5.7.4.16 Additional info regarding hysteresis operating mode

The following Pre-sets modes use a hysteresis-based logic to activate and deactivate the relay:

- Battery voltage
- Battery SOC
- Battery temperature
- Solar excess Ongrid
- On AC power

The hysteresis is given by 2 values configurable by the user: Activation threshold and deactivation threshold. According to the numerical values set into the 2 thresholds, the hysteresis can follow 2 distinct behaviours (figure below). Having a value attributed to activation threshold higher than the one attributed to deactivation will invert the hysteresis logic.

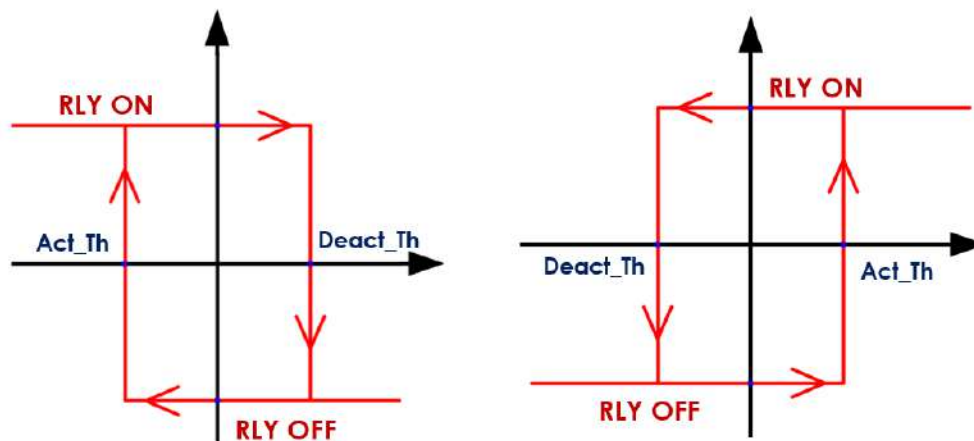

For example, the voltage battery pre-set could be configured with an $Act_Th < Deact_Th$ to activate a generator and charge the battery when the voltage is too low. The generator is then stopped when the voltage corresponding to a charged battery is reached ($Deact_Th$). The inverted hysteresis ($Act_Th > Deact_Th$) could be used for example to connect an additional load when the voltage reaches a level of battery charged (Act_Th). This load is then disconnected if the battery voltage reaches the $Deact_Th$ level.

5.7.4.17 Additional info regarding Temporal Restriction

A temporal restriction can be applied to all the pre-sets mode except "Scheduled time". The temporal restriction can be seen as an intermediate block between the signal of activation and the relay coil. The following parameters can be set:

- **Activation Min Delay [sec]:** Minimum delay before activation. The condition signal must be high during all this period to activate the output.
- **Deactivation Min Delay [sec]:** Minimum delay before deactivation. The condition signal must be low during all this period to deactivate the output.
- **Activation Min Time [sec]:** Minimum time during which the relay remains in activated position.
- **Deactivation Min Time [sec]:** Minimum time during which the relay remains in deactivated position.
- **Activation Max Time [sec]:** Maximum time during which the relay remains in activated position. To disable this parameter, enter the "-1" value.
- **Activation Hour Allowed 1&2 [sec]:** Daily time range during which the relay activation is allowed. The 2 daily hours are given in seconds starting from midnight.
- **Activation Weekdays Allowed:** Weekdays allowing the relay to be activated. The different days are represented in a bitfield format corresponding to:

Bit6	Bit5	Bit4	Bit3	Bit2	Bit1	Bit 0
Monday	Tuesday	Wednesday	Thursday	Friday	Saturday	Sunday

Below an example of temporal restriction applied to a pre-set condition:
Parameters:

Activation Min. Delay	1 [sec]
Deactivation Min. Delay	2 [sec]
Activation Min. Time	4 [sec]
Deactivation Min. Time	4 [sec]
Activation Max. Time	15 [sec]
Activation Hour Allow1	12 :00
Activation Hour Allow2	12 :00
Activation Week Days Allow	All days selected

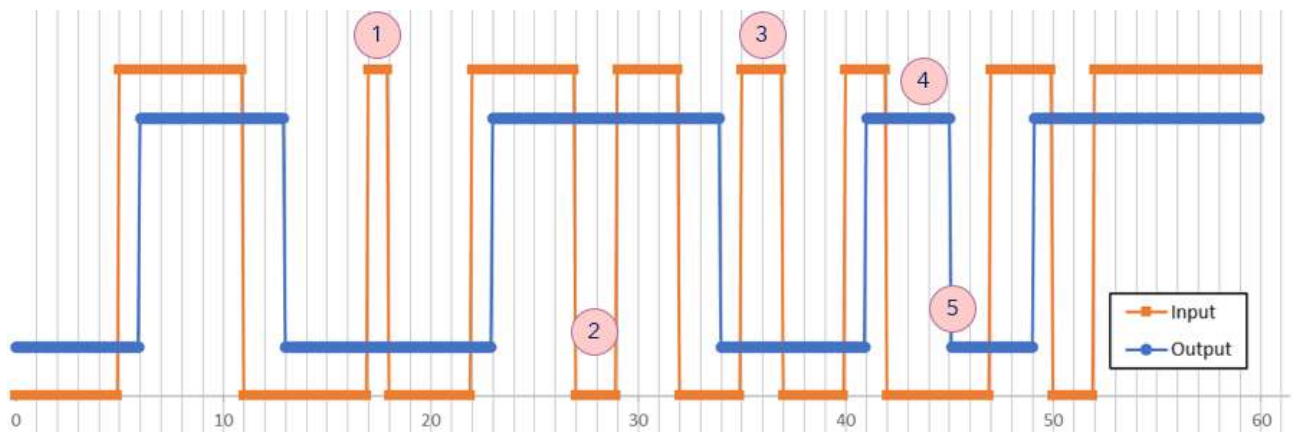

- On time < Activation Min. Delay
- Off time < Deactivation Min. Delay
- Input signal is active during deactivation Min.Time
- Activation Min. Time
- Deactivation Min Time

Example with "Activation Max. time":

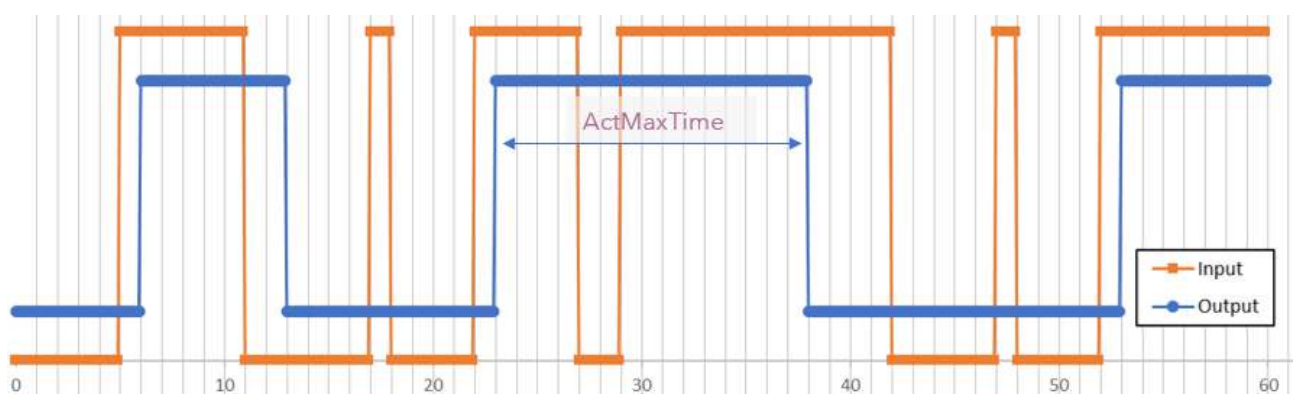

If the activation max. time is reached and the activation condition is still present, the contact will not be reactivated as long as the condition is present. The contact will remain locked in deactivated state until the activation condition disappears or the user switches to manual Off operating mode. Use this parameter with care and only as a security.

5.7.4.18 Detailed AC-FLEX settings list

The full list (expert level) of settings and information with their description are available in appendix of this manual.

5.8 System settings



There are settings related to the whole installation and not only one part or one device. The system information and settings are accessed with the central sign next on the synoptic.

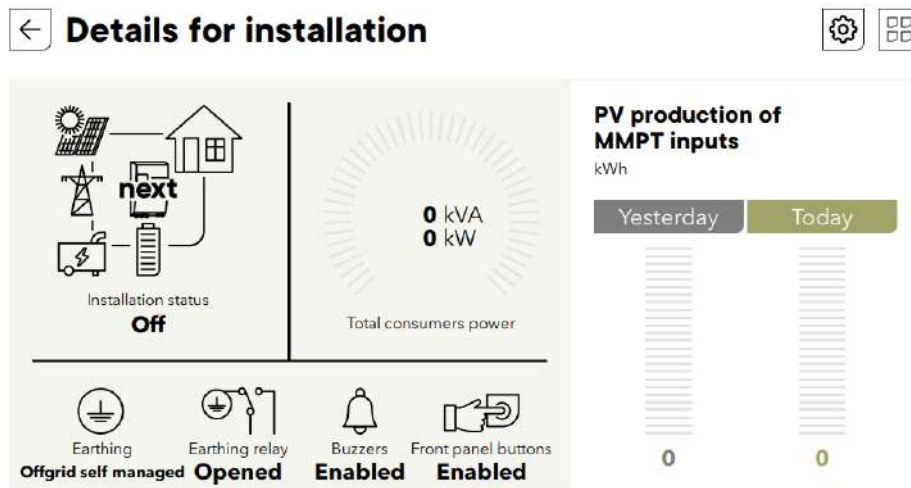
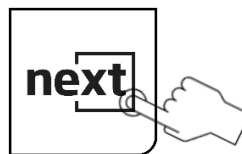

“System” or “installation” means elements concerning many devices at the same time (in multi-units) and that couldn’t be placed in an individual menu. Per example the grounding impacts all the elements at the same time. Similar for the neutral regime, it cannot be programmed individually.

5.8.1 Neutral and earthing relay

The protective earth must be connected in accordance with local standards and regulations in force. To do this, the next3/1 with transfer is equipped with a programmable earthing relay able to bond the Neutral wire (on Load side) to the earth (case of the device).

This relay can be configured in the following mode:

- Offgrid self-managed** (default): With “Offgrid self-managed” selected the system will handle the connection and disconnection of the earthing relay depending on the inverter working mode: Offgrid or Ongrid. This mode can only be selected in a discontinuous neutral wiring configuration.
 Between each Ongrid-Offgrid transition a relay inspection is realized and the grounding path is validated to ensure system safety.

Typical installations where “Offgrid self-managed” should be selected are:

- o Mobile installations.
- o Installations connected to grid/genset via a plug connector.
- o Standard stationary installations.

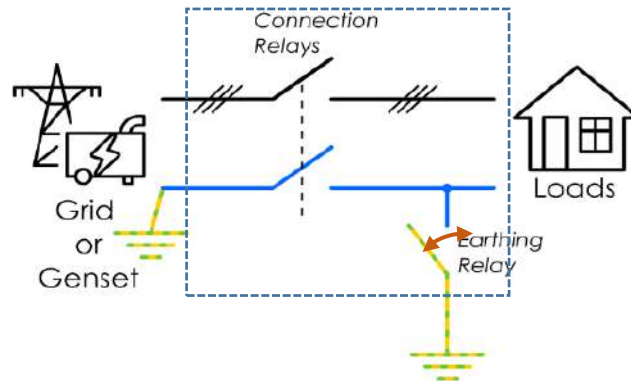

With this mode a permanent check of the neutral voltage is performed. RCD breakers should be placed on the load side.

- **Solid neutral:** This configuration is used when continuous neutral is required. In this case the system will never close the earthing relay since the Neutral to earth bonding should exist downstream. Grounding path is monitored to ensure system safety. An error is raised if grounding is not correct or if neutral continuity is not correct. Typical installations where “Solid neutral” should be selected are stationary installations where local rules specify explicitly continuous neutral wiring.

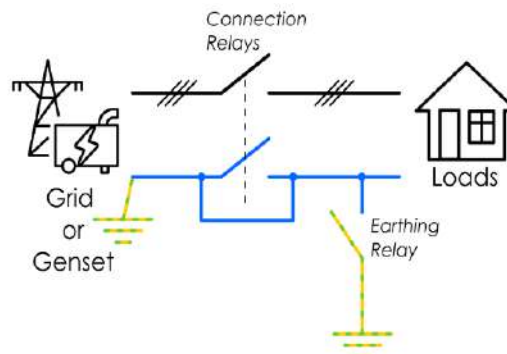

- **Disabled:** Disabled mode keeps earthing relay opened and no earthing path verification is realized. This mode should be used with precaution since user must ensure installation safety in any case. Typical installations where “Disabled” should be selected are installations with IT earthing system. In an IT network there is no grounding connection and safety isolation is ensured by an external impedance check device.

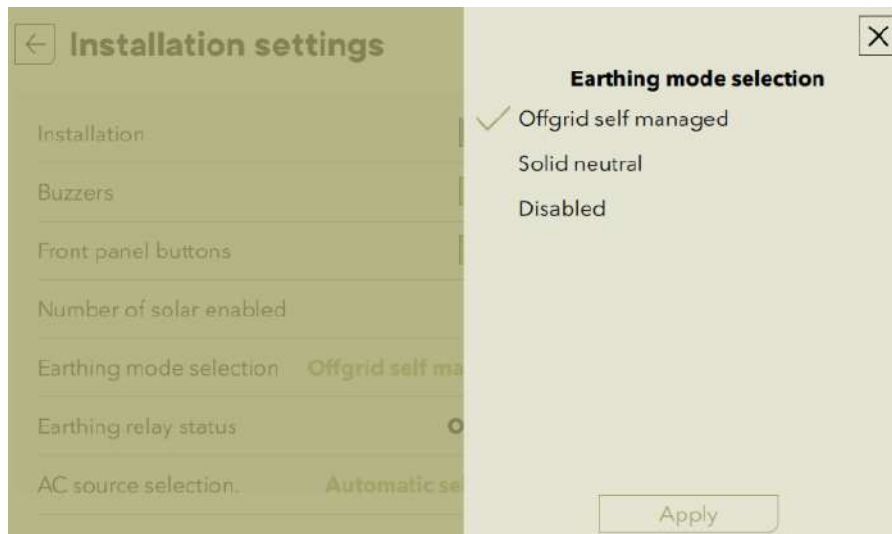

There is a check on the neutral-earth isolation in function of each case except for disabled.

The selection of the operating mode depends on the wiring configuration and the local standards. Refer to chapter about wiring in the manual of your inverter for the earth wiring information.

5.8.2 Source priority

When several AC-sources exists, the one that will be used is determined according to this setting:

- Automatic selection: the first AC source with voltage and frequency in the allowed range is used and kept as long as it is correct.
- Main AC-source or grid: the AC-source connection configured for the grid has priority (in multi-unit system the AC-source of an inverter can be configured as grid and another for genset). If a genset is used and the grid comes in, the next switch to the grid.
- Secondary AC-source or genset: genset AC-port has priority.
- None : all are disabled

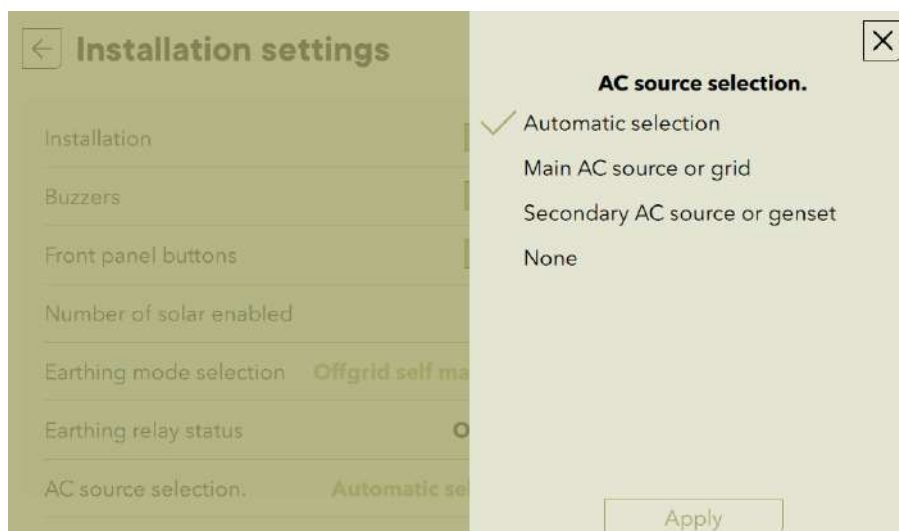

5.9 Device and I/O: Aux contacts, Inputs and communication

This part is for one next unit and the hardware belonging to one unit. The information and settings are accessed by sliding right from the system screen (entered with the central sign next on the synoptic).

There are as many screens as the number of next that can be accessed with the left/right slide:



5.9.1 General points

One next3/1 inverter is equipped with the following interfaces:

- 2 AUX-contacts:
 - The auxiliary contacts are useful for simple automation tasks in energy systems such as load management, automatic start of generator, simple self-consumption optimisation, ...
 - The unpowered state of the relay is a contact between C (common) and NC (normally closed). When the auxiliary relay is activated, the contacts switchover and is between C and NO (normally open).

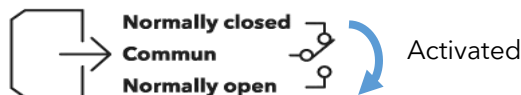

- 2 remote entries:
 - The remote entries IN1 and IN2 are inputs that can be active with a 5 to 60Vdc voltage to the return reference. An +12V supply is available on the connector for the use of dry contacts. Don't use it for other purpose than the activation of input entries.

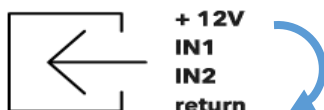

Give a voltage signal between on of the IN and the return.

The +12V can be directly for this

The various possibilities are given with the schematics below

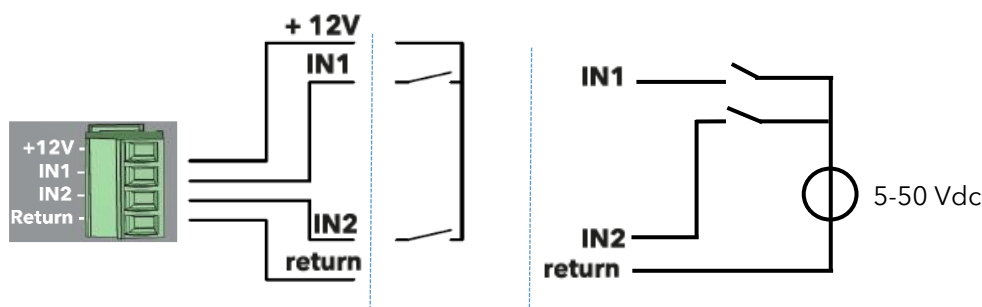

For activation with a dry contact:
Supply voltage with +12V, go to the contact and come back to the wanted

For activation with an external source: a potential of 5Vdc to 60Vdc must be applied between an input and the return

External 12V can be deactivated with settings in the device menu (on nx-interface).

- 1 RS485i for M2M communication. It is not used in first versions of the software and will come with future firmware updates. Control of the next3 system with MODBUS is performed through the nx-interface port and not the physical port situated on the next3 itself.

- 1CANi for lithium BMS communication (setup in the battery menu, see the battery chapter of this manual).

5.9.2 Device Information

On the nx-interface, the information screen for the device and its auxiliaries is shown below:

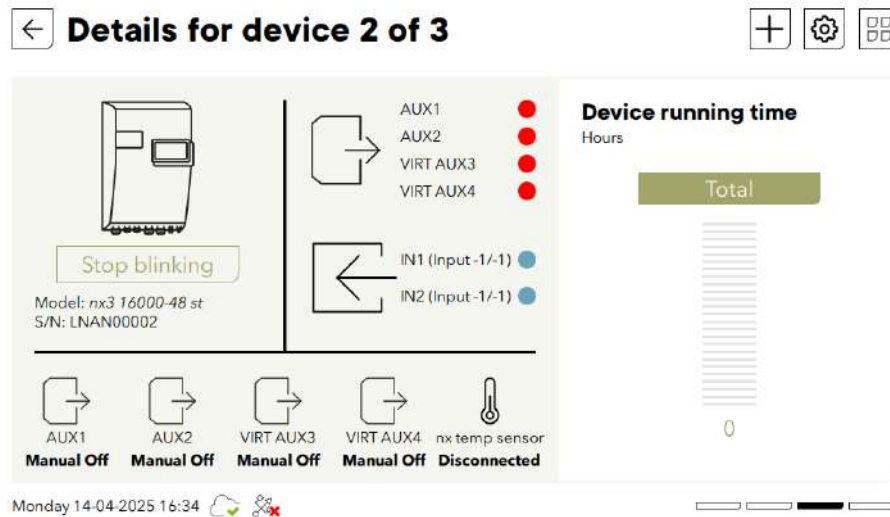

Explanation:

Red point: means the relay/entry is deactivated. For the relay, it means it is in the NC position.
 Green point: means the relay/entry is activated. For the relay, it means it is in the NO position.

A list of all available information can be accessed with the + sign from this screen:



5.9.3 AUX-contacts settings

The auxiliary contacts can be programmed to open and close under various conditions. For the end-user, the most common use of the contact is to start a generator, or to switch on/off a load (up to 16A ac).

The programming is done mainly with a simplified menu (at level 3) proposing the choice between Modes:

- **Manual OFF:** always deactivated, in position NO. This is also the unpowered state.
- **Manual ON:** always activated, in position NC
- **AUTO:** some activation/deactivations conditions are used. This list of possibilities are exactly the same as for the Flex load and will not be repeated below.
 - → **Please see the programming of the FLEX contacts, the list of possibilities is identical**

5.9.3.1 Combination of conditions: Advanced logics

2 independent conditions can be programmed with all the possibilities described above. The two conditions are programmed on “virtual relays” that are called AUX3 and AUX4 and that are accessible in the menu after the real physical relays 1 and 2:



The state of those conditions can be observed on the screen as the VIRT AUX3 and 4:

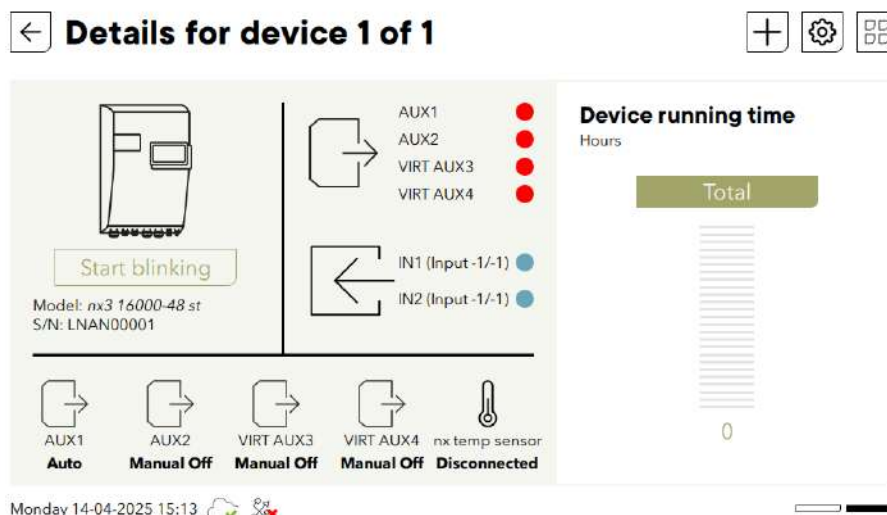

In this mode they can be combined with the following codes:

- Combination **3233857728**: AUX3 and AUX4: logical AND, both conditions must be met.
- Combination **4244438268**: AUX3 or AUX4: logical OR, one of the two must be met

For more complex combinations, please contact Studer-Innotec to get other codes.

← **Device 1 of 1: AUX relay 1 settings**
+
☰

Operating mode	Auto
Auto mode selection	Advanced logics
Temp. restr. act. min delay	1 s
Temp. restr. deact. min delay	1 s
Advanced logics combination	3233857728



Normally closed
Common
Normally open



↑
Page 1/5
↓

Monday 14-04-2025 15:33   

5.9.4 IN-CMD settings

The remote entry is used to give orders to the next system with external contacts. It can be useful to perform simple automation tasks with the next.

	<p>Then command input 1 is used for DRM0 function in the Australian version and cannot be freely programmed.</p>
--	--

The CMD menu is situated in the device (click on the next icon in the middle of the synoptic)

← **Device 1 of 2 : Command input settings**
+
☰

Command input 1 inverted	<input type="checkbox"/>
Command input 2 inverted	<input type="checkbox"/>
Enable +12V	<input checked="" type="checkbox"/>

↑
Page 3/3
↓

The following functions can be activated through the command entries:

- Connect AC-FLEX loads
- Activate an AUX contact
- Stop the inverter
- Change the charge/discharge levels of the battery for voltage, current, SOC.
- ... More possibilities will be implemented in the future.

The settings are dispatched in each part of the next, and there is no special menu for command entry. For example, the activation of the flex load with command entry is shown below; it is situated in the :

← **AC FlexLoads 1 settings: L2**
+
☰

Operating mode	Auto
Auto mode selection	Cmd entry
Temp Restr. Act. Min Delay	0 s
Temp Restr. Deact. Min Delay	0 s
CmdEntry select index	0

↑
Page 2/3
↓

The CmdEntry selection index gives which entry is considered.

5.9.5 RS485i Settings

The RS485i connection on the next3 itself is unused for the moment. Functionalities will be added in the future software updates. Keep in touch...

There is a Modbus RTU RS485 on the nx-interface. The RS485 connection on the next1 is for Modbus RTU. It is similar to one on the nx-interface.

6 Special applications

6.1 AC-coupling / AC-solar

AC-coupling is the use of battery inverters and PV inverters in the same system. The different elements are connected via the AC lines.

The AC-coupling can be useful in various situations.

- To add solar on an existing nx system directly in AC.
- To update an existing solar system with more solar and batteries with the use of the next3/1. The grid inverter is left in place and some additional solar is connected to the new next3. It is a premium choice for the case where microinverter or optimizers are used because it would be complicated to rewire the solar roof.
- It is also interesting for large systems, as it is not always wanted to have the full power with the backup inverter. Per example a 50kW solar system with 30kW of backup capacity would have 2 next3 in parallel and a grid inverter with up to 30kW of solar.

6.1.1 General system design

Studer-Innotec advises the following design rules for AC-coupling systems:

- The solar power in Ac-coupling should be smaller than the battery inverter power.
 - For one nx3, the AC-coupled solar should be smaller or equal to 15kW.
- The grid inverter should have the modern function of power production reduction in function of the frequency of the grid to work in island mode. Else use to the simplified AC-coupling configuration.
- The battery capacity should be sufficient to absorb all the AC-coupled power.
 - At least C/5 power with lead acid battery
 - At least C/2 power with lithium battery
- For robustness of the system use a mix of AC-coupling and DC-coupling.
 - This allows for black start of the units after an undervoltage of the battery.
 - With ac-coupling, if the battery inverter is stopped, everything is stopped.
- In case of use of a genset on AC.-source instead of the grid, it is not allowed to have backfeeding to the genset. It may be causing troubles to the generator.
 - In that case the designer must take countermeasures to avoid this. The simplest way is to disconnect the solar inverter when the genset is connected.
- The standard way to make AC-coupling is to use of the AC-FLEX connection with the proper settings. That way all the solar can be monitored automatically. This is important to understand later what happens in the system for the end user of the system.

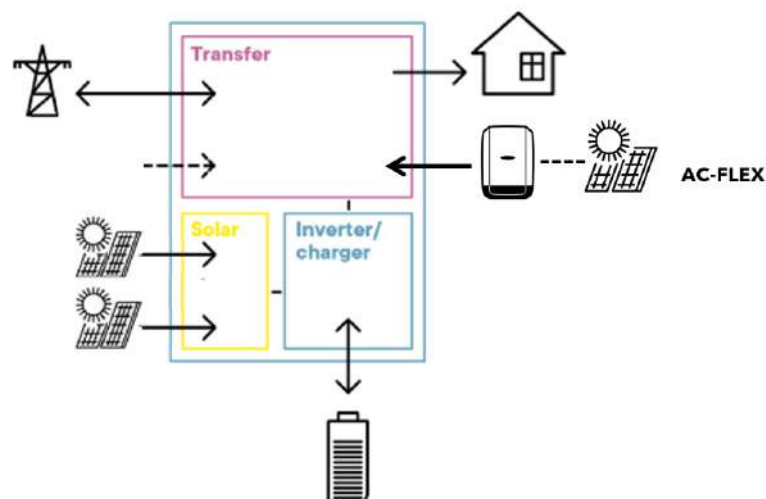

6.1.2 AC-coupling with frequency shift

The frequency shift control uses the properties of grid inverters that must reduce the power production when the frequency of the grid increases in order to participate to the grid stability. The frequency between 50 and 50.2Hz is used for primary control of the grid. The solar inverter must reduce linearly their power production between 50.2 and 51.5Hz.

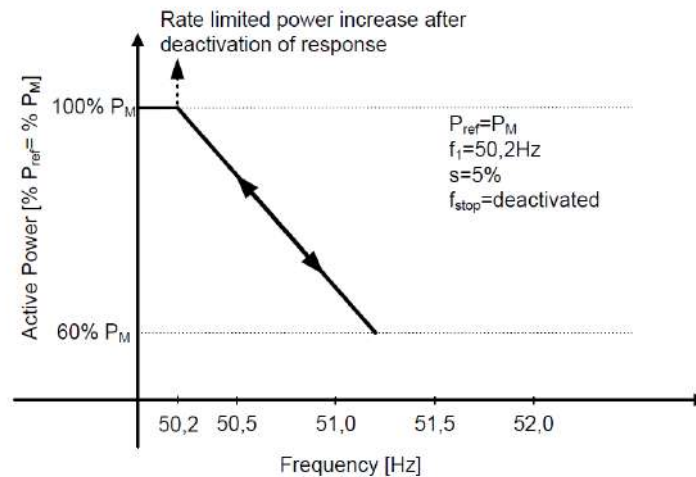

In Offgrid mode, the next3/1 creates the voltage/frequency and then will modulate the frequency in function of the energy needs in the system.

6.1.2.1 Setup

The main programming is done at the commissioning of the installation during the wizard. This is the quickest and safest way to program the system. The answer YES to the AC-coupling question will set the proper values to all the individual settings given below. The question is asked during the AC configuration:

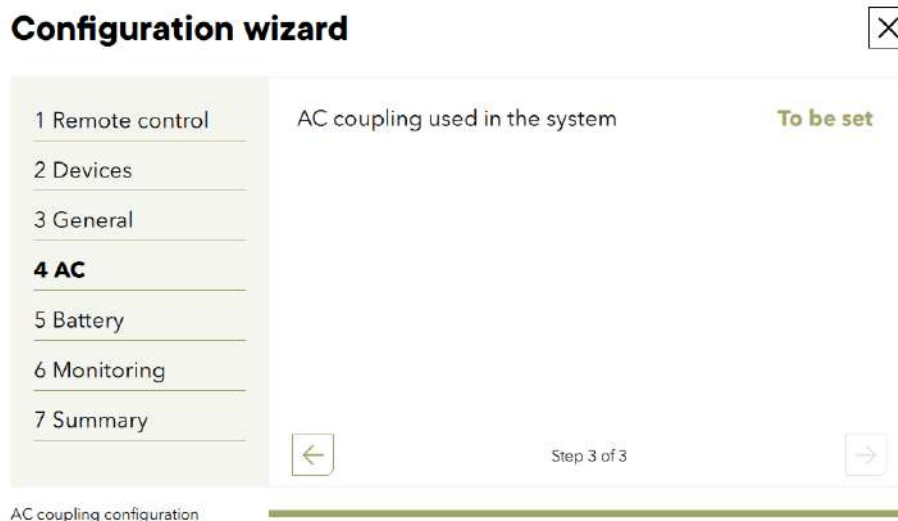

The max frequency increase is set by default to 2.5Hz which corresponds to today grid codes. Don't modify it except if you have special or old grid inverters.

Configuration wizard



1 Remote control

2 Devices

3 General

4 AC

5 Battery

6 Monitoring

7 Summary

AC coupling used in the system Yes

A grid inverter is connected to the AC-Loads or AC-Flex port. Make sure it has the proper response to frequency change.

Maximum frequency increase to reduce solar production 2.5 Hz

←
Step 3 of 3
→

AC coupling configuration

If the AC-coupling is connected to the AC-Flex, the relay programming to have it always connected must be done later with individual settings. If lithium batteries are used there is also special programming to do. Please read the following chapter anyway.

The grid inverter is connected to AC-FLEX and the relay must be always close. To program this, click on the AC-Flex part.

🔌 🔔 **Synoptic**
⊕ 📱

V	A	kW	0 kW
231	0	0	0 kWh
230	0	0	0 kWh
229	0	0	0 kWh

V	A	kW	5 kW
231	2.2	0.5	29.4 kWh
230	10.9	2.5	
229	8.7	2	

V	A	kW	0 kW
0	0	0	0 kWh
0	0	0	0 kWh
0	0	0	0 kWh

-5 kW	20 %
-29 kWh	
47 V	

And in configuration

The AC-flex must be always ON for all phases:

Settings for FlexLoads 1 of 2 (L1)

Operating mode **Manual On**

OFF
ON AUTO

flex L1

For all phases in case of a 3phased grid inverter use

Page 1/3

From practice it is advised to manage the lithium battery charging a little bit differently with AC-coupling. If the battery is full, the BMS requires zero charge current and makes an error if this is not respected. In transitions from grid connected to offgrid, there is the risk to have the production of the grid inverter that is maintained for a few seconds, during the time it takes for the grid inverter to react to the increasing frequency. To limit the risk of having a battery error in that transition, Studer advises to use an charge at charge à 95% with a periodical full charge.

Synoptic

V	A	kW	0 kW
231	0	0	0 kWh
230	0	0	0 kWh
229	0	0	0 kWh

V	A	kW	5 kW
231	2.2	0.5	29.4 kWh
230	10.9	2.5	
229	8.7	2	

V	A	kW	0 kW
0	0	0	0 kWh
0	0	0	0 kWh
0	0	0	0 kWh

kW	kWh	V	SOC
-5	-29	47	20%

Then the config and the advanced list

Set the 1.1.2.30 SOC for end of charge at 95% and check that the periodical charge at 100% is enabled.

← Settings list for battery 1 of 1



Ignore BMS recommended currents	<input type="checkbox"/>	ID 1.1.2.84
Current limits margining factor	0.95	ID 1.1.2.27
Conditions for energy management	Show	ID 1.1.2.28
SOC slope for limits	-80 A/%	ID 1.1.2.29
SOC for end of charge	95 %	ID 1.1.2.30
SOC for grid feeding	95 %	ID 1.1.2.31
SOC for backup	20 %	ID 1.1.2.32
SOC for end of discharge	15 %	ID 1.1.2.75

← Settings list for battery 1 of 1



SOC to increase adaptive SOC for...	98 %	ID 1.1.2.37
Periodical charge and discharge	<input checked="" type="checkbox"/>	ID 1.1.2.72
Delay before periodical charge	604800 s	ID 1.1.2.73
Delay before periodical discharge	7776000 s	ID 1.1.2.98
Periodical charge SOC	100 %	ID 1.1.2.95
Periodical discharge SOC	100 %	ID 1.1.2.96
Time before resetting periodical (d...	600 s	ID 1.1.2.74

6.1.3 Simplified AC-coupling (no island mode) with AC-Flex

This case is for grid connected system with an existing grid inverter that would not respond to frequency increase with a reduction of power. In that case it is necessary to disconnect the inverter in case of island mode because it is not safe to work with an uncontrolled recharged of the battery.

This works with any kind of grid inverters and there are no special requirements on the grid inverter. The unit may not be compatible with frequency shift control, that is why it must be used with grid presence only and the grid inverter is disconnected when going to island mode. This prevents unwanted/uncontrolled charging of the battery.

The connection/disconnection of the grid inverter is performed with the AC-flex relay with the proper programming given below.

6.1.3.1 Setup

The AC-Flex must be configured as a load in the configuration wizard. Answer NO to question of genset presence.

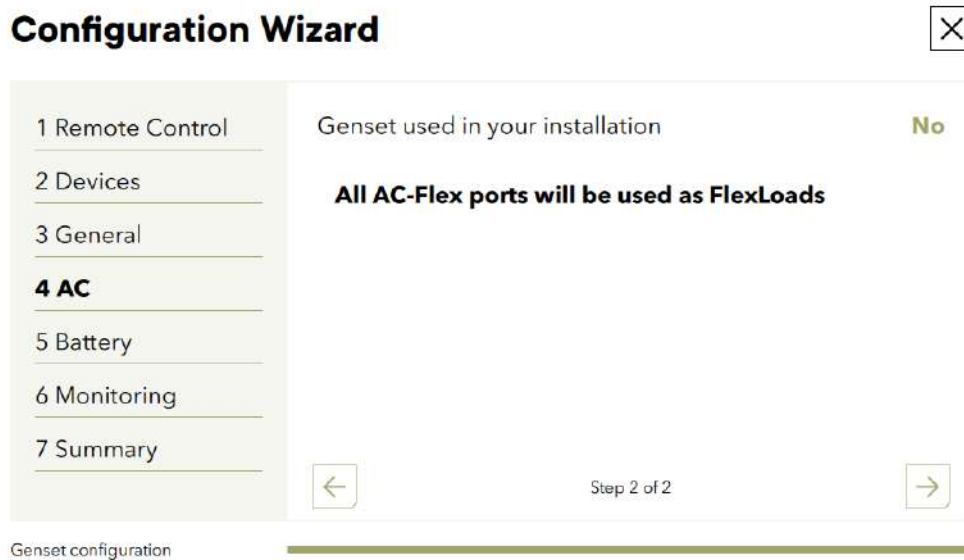

And Yes to the AC-coupling question.

The connection/disconnection in function of grid presence must be setup. Click on the AC-Flex part.

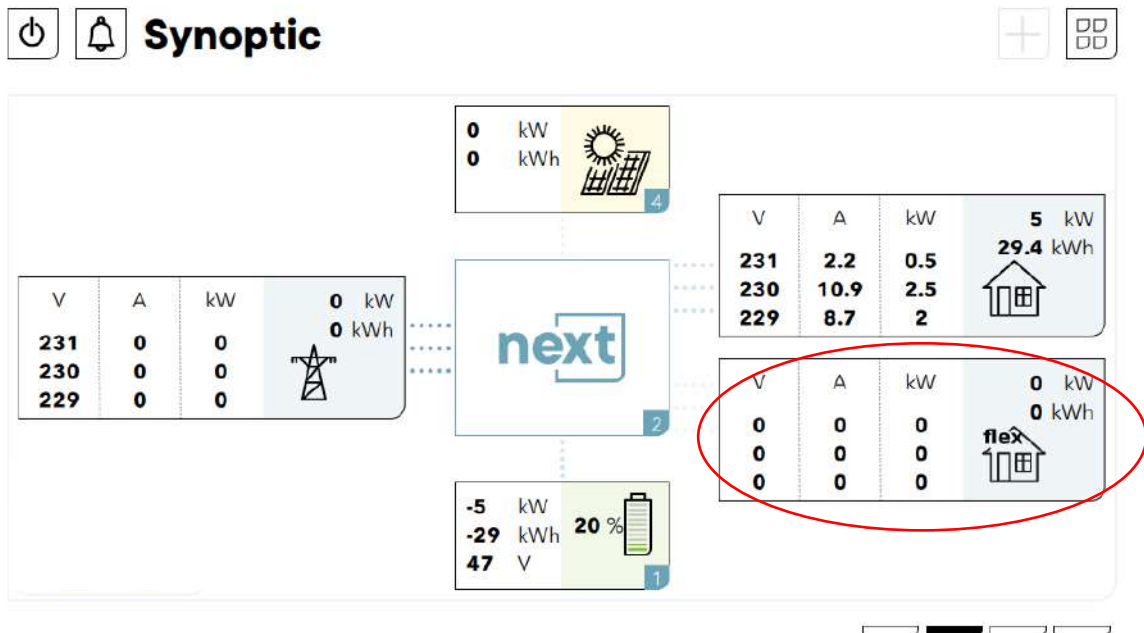

And in configuration

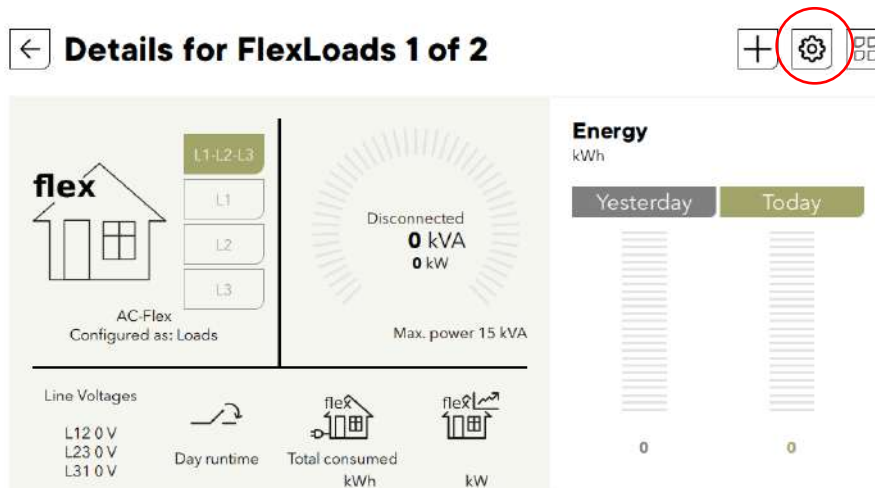

Change for each phase (for 3 phased grid inverters), the operating mode to AUTO.

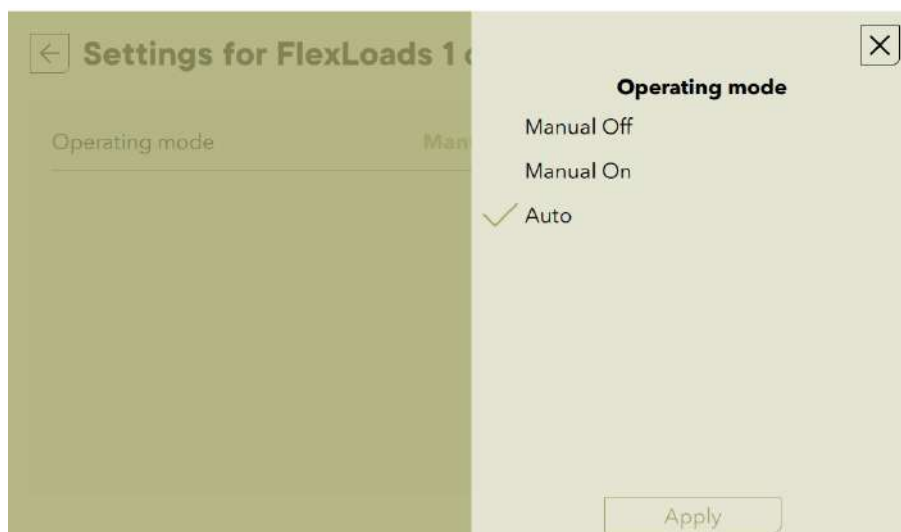
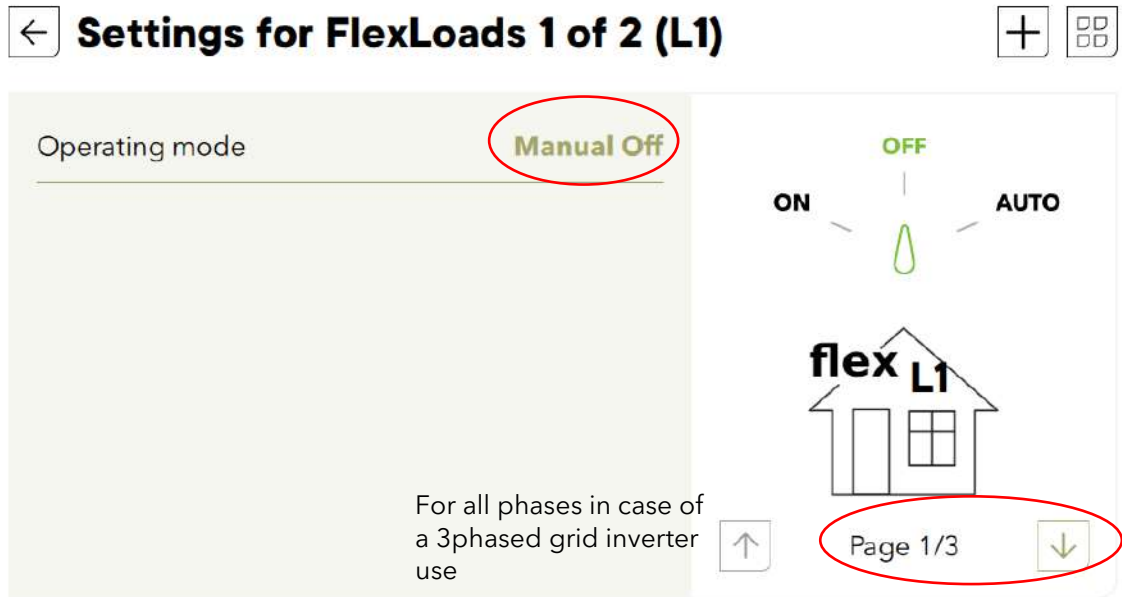

And set the connection condition to "on-grid". Add a small delay of a few seconds to be sure the connection to the grid is stabilized.

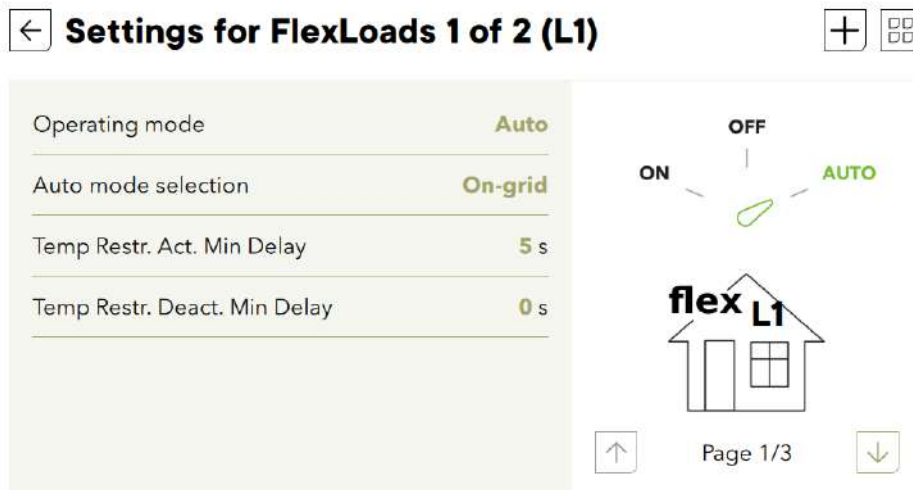

It is not a standard situation to have power coming from the AC-Load or AC-FLEX and this must be explicitly allowed with a setting, else an "back feeding" error will be raised. This is modified in the advanced settings of the AC-Loads.

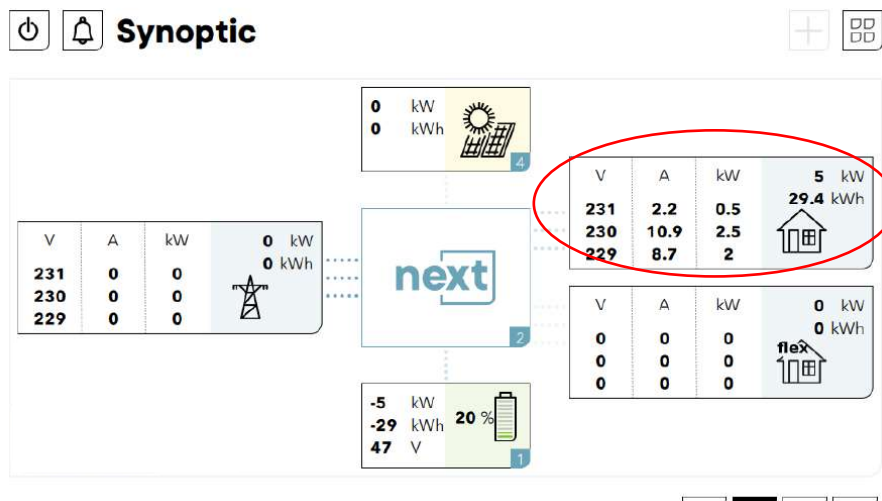

Then the config  and the advanced list 

← Settings for AC-Loads

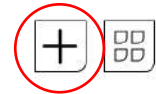

Enable inverter function	<input checked="" type="checkbox"/>
Max errors nb during obs period	5
Observation period for errors detection	60 s
Standby sensitivity	None

↑ Page 1/1 ↓

And find the 0.1.6.26 in the list and set to YES

← Settings list for AC-Loads



Relative angle for L2	-120 °	ID 0.1.6.21
Relative angle for L3	120 °	ID 0.1.6.22
NominalFrequency	50 Hz	ID 0.1.6.23
Alternate frequency	50 Hz	ID 0.1.6.24
CmdEntryIdxForAlternateFrequency	0	ID 0.1.6.25
Allow power sinking from AcLoad...	<input checked="" type="checkbox"/>	ID 0.1.6.26
Frequency increase to limit AcLoa...	5 Hz	ID 0.1.6.27

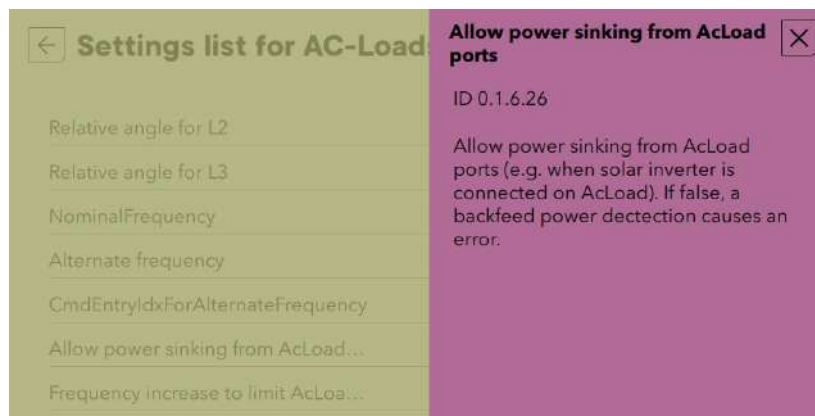

6.1.4 Example of use

Example by a customer having installed a mix of AC and DC-coupling:
 The power production is monitored with the AC-flex measurement. The power flux on this connection is seen negative.

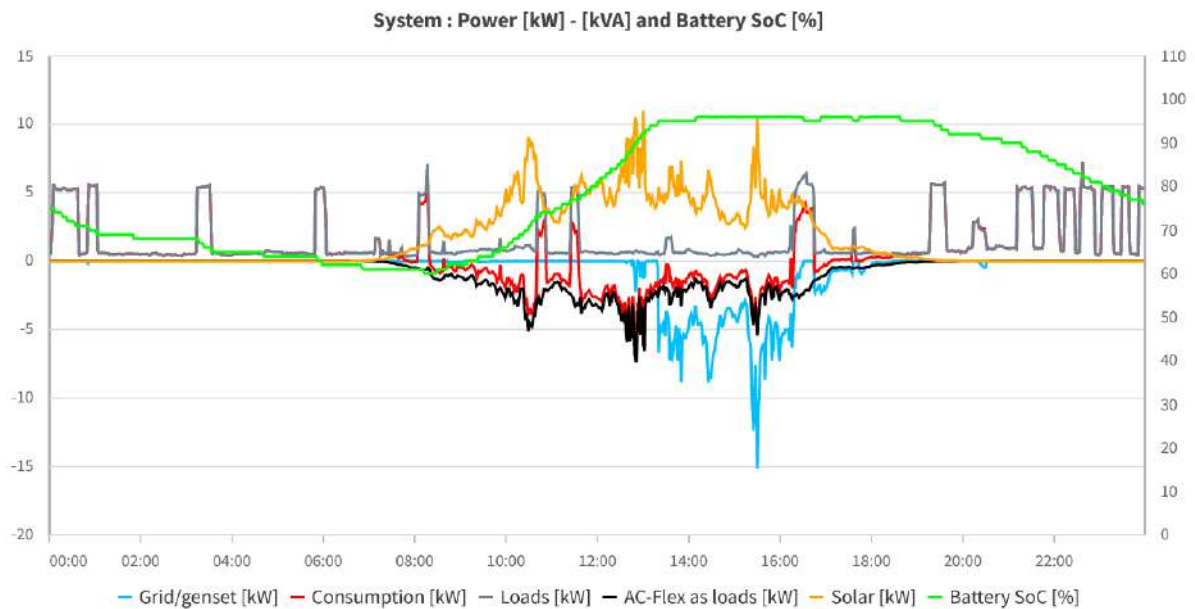

6.2 DC-coupling/DC-solar: integration of Studer solar chargers vario in the system

Compatibility with the existing solar charger of Studer is possible with a communication bridge

Compatible elements are:

- Variostring VS-70 and VS-120
- Variotrack VT-40-145, VT-65-175 and VT80-175

These elements can be connected to the next system exclusively with a communication bridge xcom485i. Never connect directly the solar chargers to the next1 (or next3). The Xtender communication bus and the Next communication bus are not compatible.

Up to 5 chargers can be connected in a system.

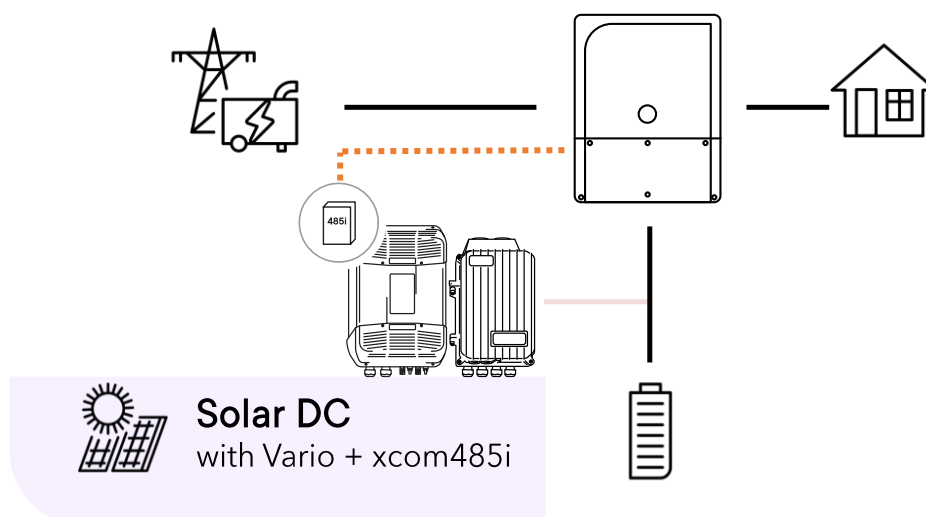

The presence of the external solar chargers must be configured during the commissioning wizard.

6.2.1 Xcom485i-nx configuration

The Xcom485i must be configured according to the following picture and with a software version later than 1.6.96 (R704).

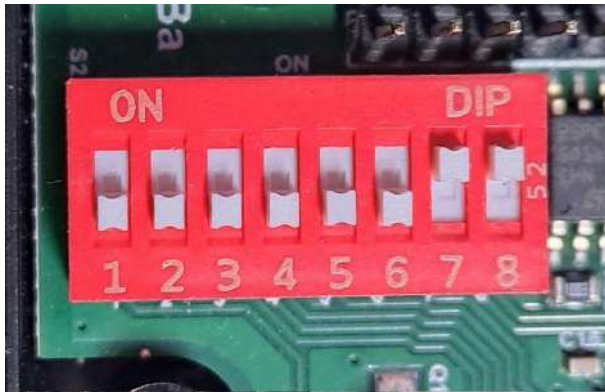

	NU		NU
RS485 P	1	RS485 N	2
	GND		GND
RS485 P	3	RS485 N	4
	NU		NU
RS485 P	5	RS485 N	6
	GND		GND
RS485 P	7	RS485 N	8
	NU		NU

This is for a connection to the next1: (note: N for negative = D- / P for positive = D+)

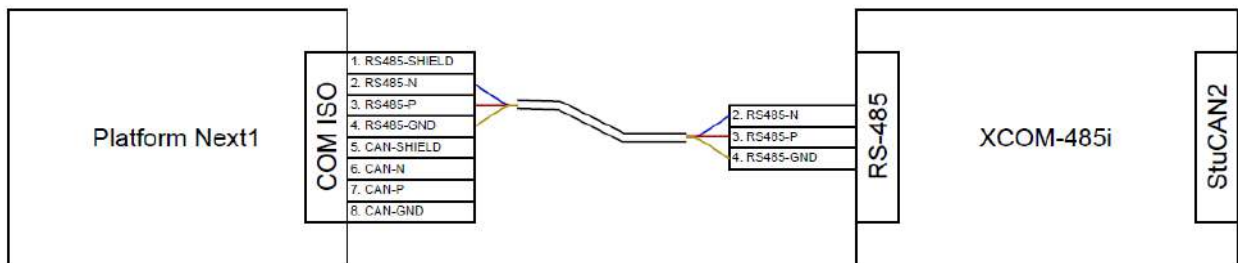

The connection to the next3 is done on the dedicated RS485 connector:

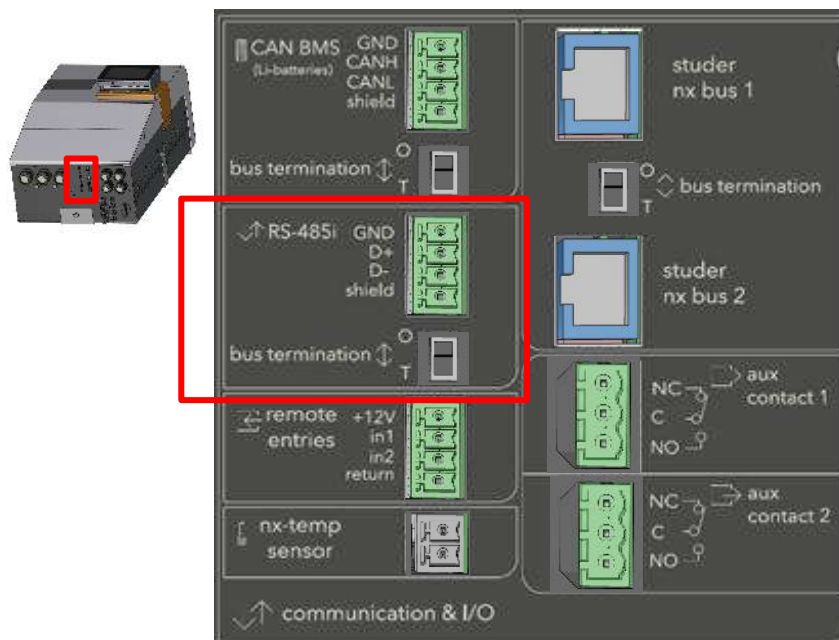

Order an xcom485i-nx kit with number [119017]:

- Already configured with proper software.
- 2 Cables provided (2x2m)
- Update of Vario and Xcom 485i with SD card and RCC!

6.3 next3 external bypass for redundancy

The next3 is an all-in-one hybrid solar inverter (with battery). This device is connected between the grid and the house, directly after the introduction and the main meter. The grid is connected to the AC-source terminal, the loads are connected to the AC-Loads and AC-Flex terminals. The AC-Loads and AC-Flex terminals can be powered by the batteries in case of a mains failure. An internal relay in the next3 device opens in the event of a power failure.

The AC-Flex output is a second output of the inverter which can be driven (internal relay of the device) or simply used to measure the consumptions separately (the Next3 monitors/records all electrical flows).

A bypass should be installed for redundancy in case of inverter failure. A double bypass can be installed if AC-Flex is used.

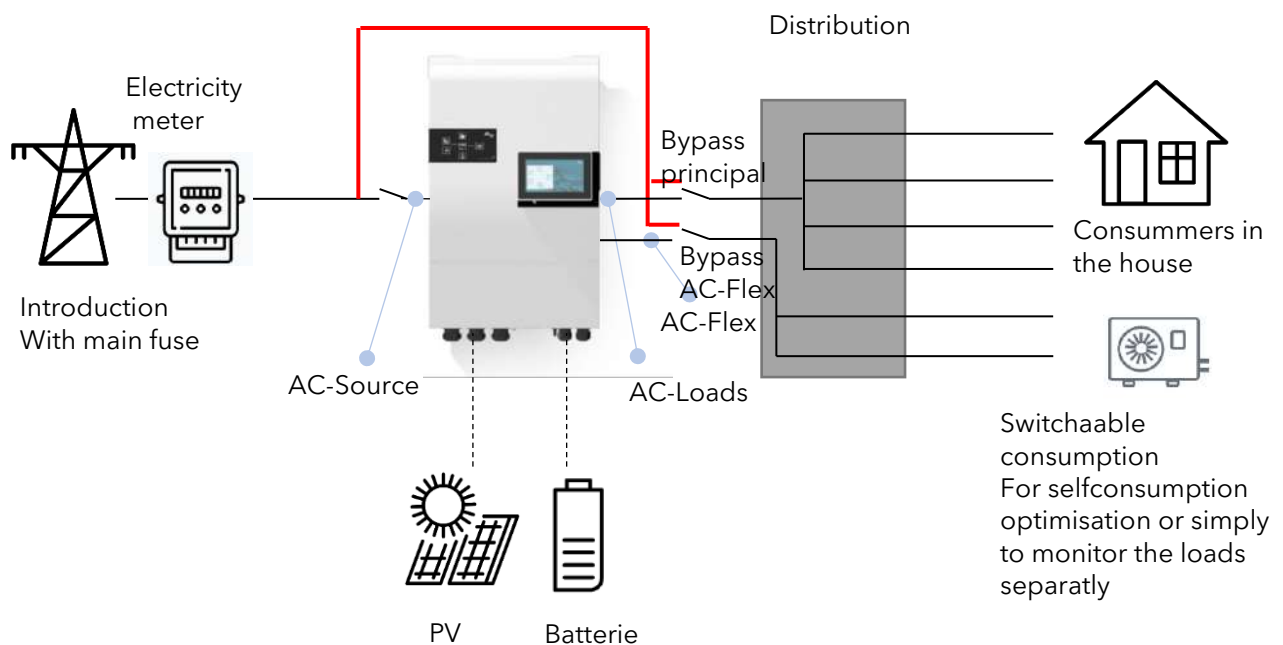

The bypass can be of several types: automatic or manual, single or double (for AC-flex included).

6.3.1 Simple manual bypass

In that case a simple manual switch over is used.

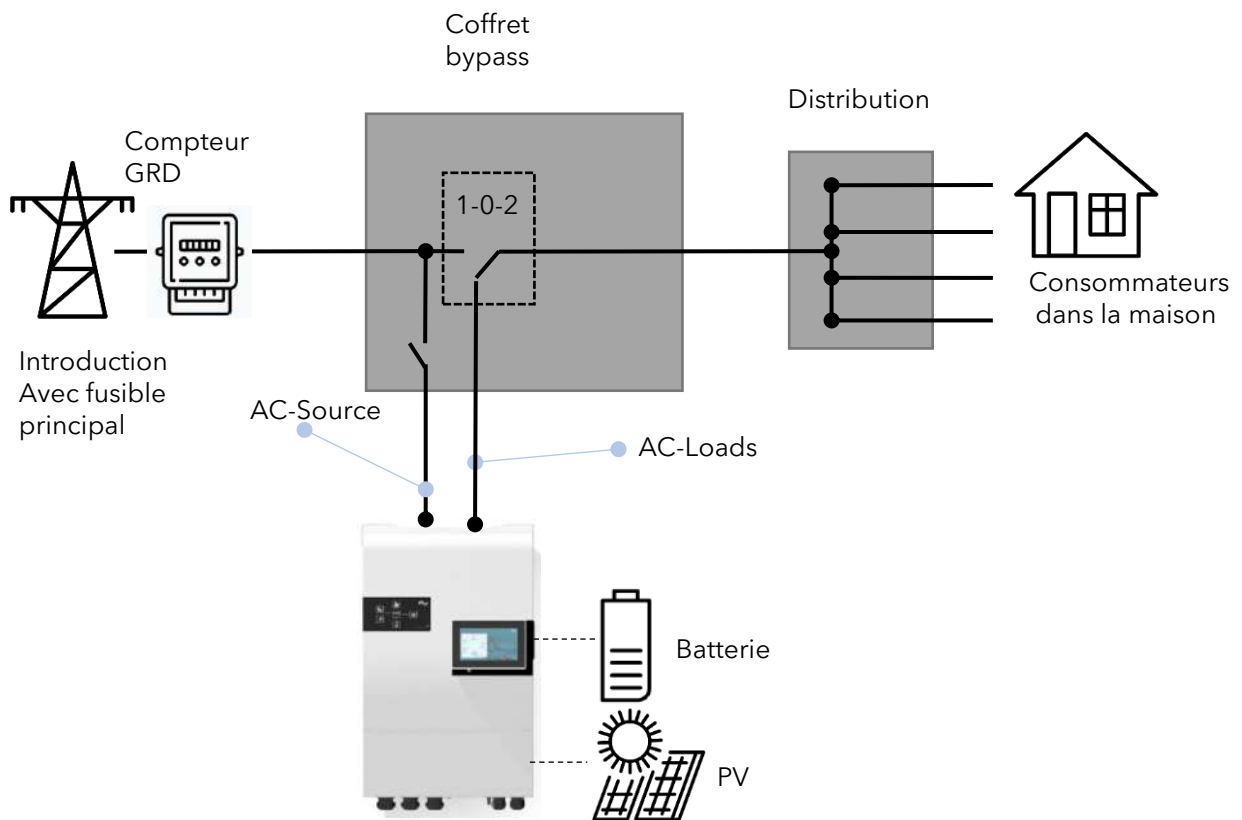

6.3.2 Automatic bypass

In this case, an automatic bypass is realized by relays controlled by the presence or absence of voltage of the grid or of the next3.

The following schematics is recommended by Studer:

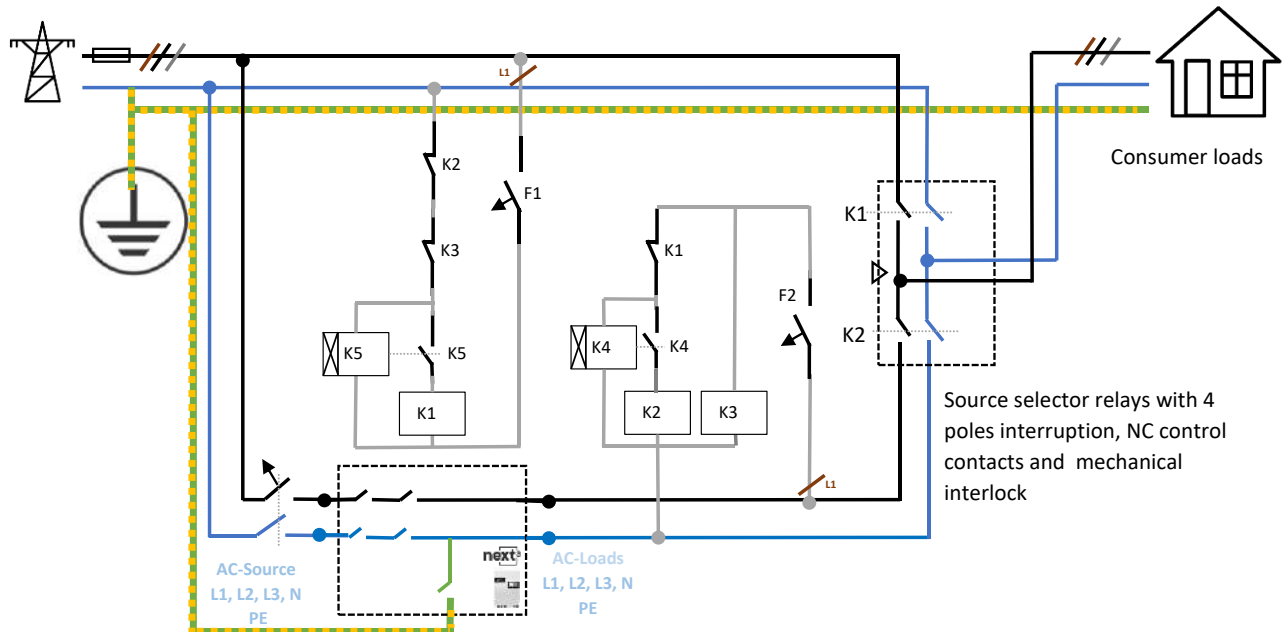

As in all source selectors, a mechanical interlock is mandatory to ensure that no short-circuit is possible. An electrical interlock of the controls guarantees a defined state. A relay is used to give priority to the next3 if is working (K3).

6.4 External control of the next1/3 by SCADA or API

Studer Innotec proposes open access and tools to integrate its devices into systems. That is the **openstuder** concept.

The next series can be monitored and controlled from outside with various means:

- With direct local control over MODBUS TCP or RTU (RS485)
- With remote control through internet and through the Studer portal API

One of the most common applications of external control is the integration in a local energy management system that considers larger view of the site for better user of energy and often control of other elements like heating system, EV charging,...

	<p>There is technical documentation for the MODBUS⁴:</p> <ul style="list-style-type: none"> • Technical specification Next Modbus v x.x.pdf • Technical specification - Next Modbus appendix v x.x.pdf <p>Examples are provided on GitHub https://github.com/studer-innotec</p> <p>There is a swagger page for the API⁵:</p> <p>The latest version of the documentation can be downloaded on Studer website</p>
---	---

6.4.1 The Object Model

Taking the control of the next3 with an PLC, or a computer means a M2M communication (machine to machine). For this it is important to understand which information can be read and which parameters that can be written. The description of the next3 is done by the next "**Object Model**" datamodel. The Object Models (OM) is organized in groups and then details are in specific sub-objects. This organization is expressed in the ID of each property (=parameter or info available) that is then associated with a Modbus register that can be R or R/W.

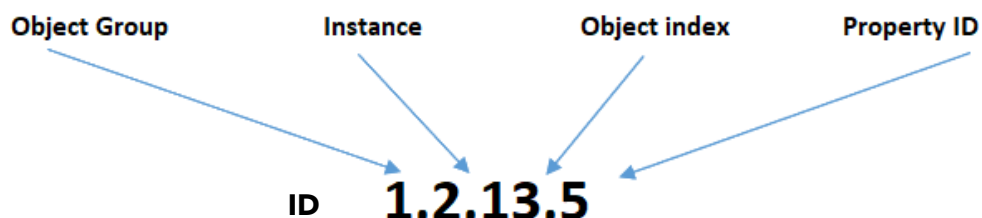

FIRST number: The **Group** (element of a system). The different objects each belong to one of the following groups:

- 0: System settings
- 1: Battery settings
- 2: AC ports as Source
- 3: AC ports as Dumpload
- 4 to 9: unused yet, reserved for future elements
- 10: Next3 (specific to the hardware found in the nx3 only)
- 11: Next1 (specific to the hardware found in the nx1 only)
- 12 to 19: unused yet, reserved for future devices
- 20: nx-interface, including the embedded nx-interface in the next1

⁴ <https://technext3.studer-innotec.com/modbus-next>

⁵ <https://api2.studer-innotec.com/swagger/>

SECOND number: The **Instance** (element of a group). That is for the case when several objects of the same type are present in the installation. For example, when there are two units of next3 in parallel with two batteries, the second is addressed with x.**2**.y.z

THIRD number: The Object **Index** for each element. For example for the battery group:

- BatteryCommon: ID = 0
- Battery: ID = 1
- BatteryCycle: ID = 2
- ...

FOURTH number: The **Property number in the object**. If we take the Solar object as an example, the different properties are each defined by an ID:

- Voltage (ID0)
- Average Voltage(ID1)
- Max Voltage (ID2), Current (ID3)
- etc...

Examples:

- The daily energy production of the 2nd PV input on the third next3 of the system is referenced with ID 10.3.62.10 (Group: 10 Next3, Instance: 3rd Next, Object ID: ObjIdSolarCommon2 = 62, Property Day energy: 10)
- The undervoltage level in charge of the second battery of a system with 1 Next3 is referenced with ID 1.2.2.2 (Group: 1 Battery settings, Instance: 2nd Battery, Object ID: BatteryCycle = 2, Property Undervoltage: 2)

Overview of groups:

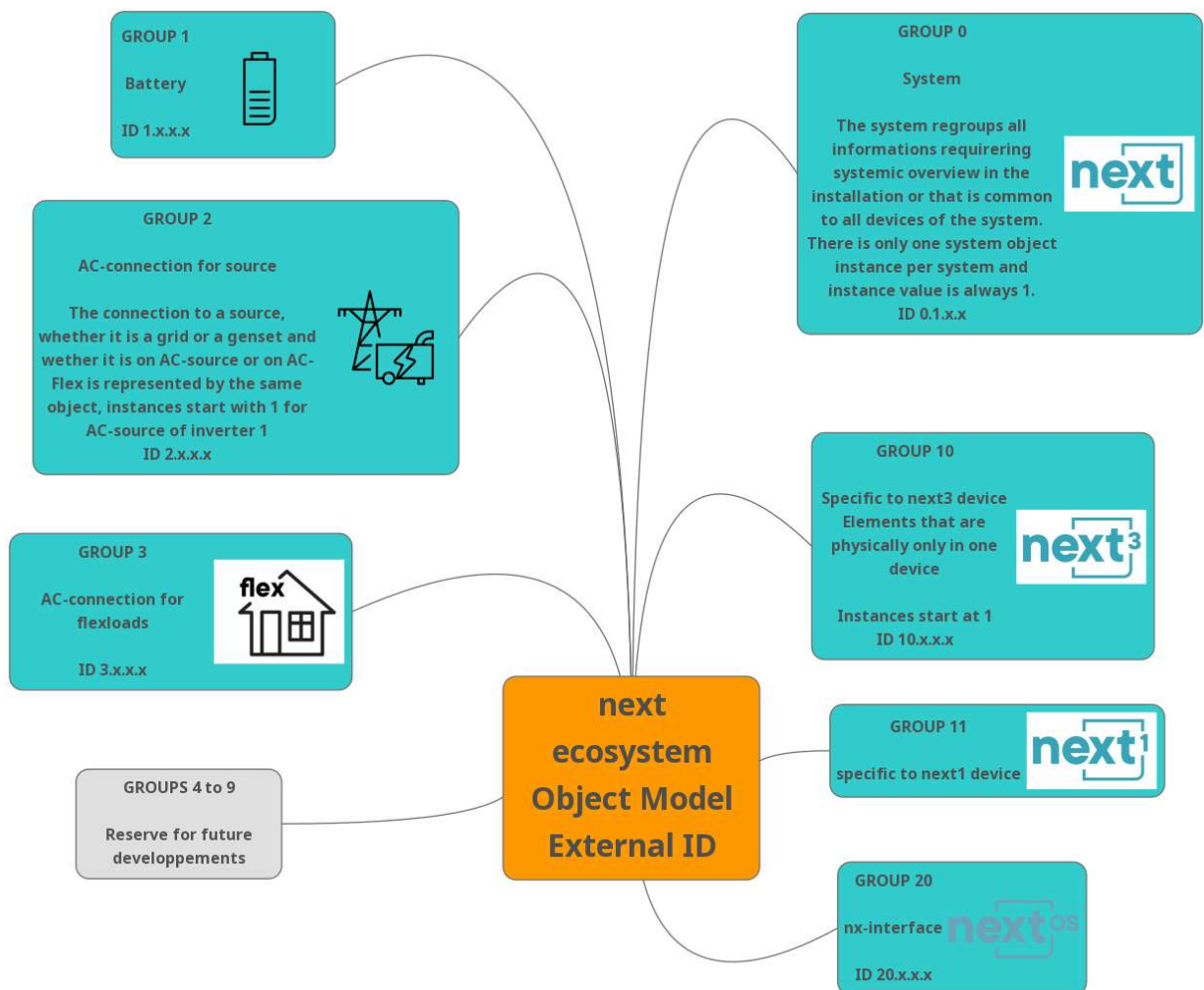

After a major update of the next system, with a different Object Model version major number (the left number, e.g. going from 6.41 to 7.0), the devices addresses can change, and the properties register addresses can change as well. Be sure to have an updated model on both side of the communication.

Useful resources available for this topic:

- The online manual with the Modbus section: <https://technext3.studer-innotec.com/modbus-next>
 - The latest version of the Object Model description is available in .pdf on that page with the list of modbus registers.
- Example in python provided on github <https://github.com/studer-innotec/next-modbus> with a mapping already realized between OM and Modbus registers.

6.4.2 Static IP for MODBUS TCP

When the nx3 or nx1 are connected to a network the IP address is normally automatically distributed by the router. The problem is that it may change over time. It is possible to set a static IP address within the network menu.

6.4.3 Securities in case of external control

When piloting a Studer next system, the original configuration (factory default or values set by the customer at commissioning) is modified. When this external control is stopped, the original configuration should be restored to be sure the system is operating as wanted in standalone mode. The interruption of control is not always planned, there can be failures, interruption of communication, bugs in control system independent of Studer system... that is why a fail-safe mechanism has been implemented in the nextOS system.

	<p>NOTE : All the mechanisms described here are available only in next firmware version from version 1.3.32.0 or higher.</p> <p>The latest version of the software can be downloaded on Studer website: https://www.studer-innotec.com</p>
---	---

The original configuration is saved on the device in the Non-Volatile Memory (NVM). The parameters used during operation are transferred to the RAM of the processor and that can then be modified frequently by an external control loop. That is important to keep the original NVM and work directly in RAM with external control.

Writing in the NVM is performed only when the configuration must be kept for later, for example the programming done at commissioning by the installer. That is normally never done by an external control system. Note that the number of writing in an NVM is limited.

The options are to read/write in NVM or RAM are controlled by:

- For Modbus:
 - Modbus write by default in the RAM only as this is its purpose. That can be modified with the activation of the ID 20.1.15.6 "Write persistently by Modbus" which will be active temporary only for 20 seconds.
 - A normal read in the RAM can be done with the function code 0x03
 - A read in the NVM can be done with the function code 0x04
 - See the full MODBUS documentation for details.
- For the API:
 - Writing is by default in the NVM, as the API is generally used by an installer to change a setting with the portal. It can be adjusted with an option in the request:
 - put endpoint on `api/v2/installations/{installationId}/properties`, `writeInRam` option to true:

Request body required

Example Value | Schema

```

{
  "properties": [
    {
      "id": "string",
      "value": "string"
    }
  ],
  "options": {
    "writeInRam": true
  }
}
```

- For reading, that can be done with an endpoint option `readFromNVM` to true/false.

At the end of the control, a clean way to stop is set back all the original values in the modified registers/parameters and then let the system run on its own.

An automatic fail-safe mechanism can be activated. It uses a timeout and will reinitialize the settings of the RAM with the original values stored in the NVM if a register is not regularly written.

This mechanism is controlled from properties of the SystemView object (20.1.28) of the next gateway. Three properties are available for full control on this mechanism :

- Property 20.1.28.2 : "Enable timeout for ext. control"
 - When set to "true", the automatic mechanism is enabled
- Property 20.1.28.3 : "Ext. control timeout duration"
 - Contains the value in seconds used for the timeout (default is 15 minutes, so 900 s.)
- Property 20.1.28.4 : "Reset external modifications"
 - Signal property, when written it triggers the restoration process and reset all properties to NVM value

6.4.3.1 Start operation of the control system

The control system should initiate its process by

1. Reading the nextOS the software version used, to make sure it is compatible
2. Reading the default values of the installation that may be needed later by control program.
3. Before starting the piloting, making sure the automatic safety mechanism is enabled:
20.1.28.2 : "Enable timeout for ext. control" set to true.
4. Changing the writeInRam option before writing anything on the system:
5. Run your control algorithm and be sure to send at least one setpoint every 10minutes (<15min by default in 20.1.28.3 : "Ext. control timeout duration")
6. Check also on the controller side that the communication was not lost and restart the control if it is the case (writeInRam and 20.1.28.2 fell back to false).

6.4.3.2 Stop the operation of the control system

After stopping the piloting, ideally manually restore the values in order to make sure the device directly functions using the original settings (without waiting for timeout)

That is done with the signal on property 20.1.28.4 : "Reset external modifications"

6.4.4 Properties/registers to control

All the registers can be read/written with the appropriate user level right. Here are the registers advised to use to make the most common tasks.

- Battery-side piloting options :
 - Change SoC consigns
 - SoC for backup (e.g. force battery charge up to that level) [%] : 1.1.2.32
 - SoC for grid-feeding (e.g. force battery discharge) [%] : 1.1.2.31
 - Note : there are min/max limits :
 - SoC for end of charge [%] : 1.1.2.30
 - SoC for end of discharge [%] : 1.1.2.75
 - Note 2 : Check for automated changes on these parameters, see last slide
 - Change battery current limits :
 - For limiting the battery charge or discharge (case where charge/discharge periods are shifted by the controller)
 - Enabling manual current limits (bool) : 1.1.2.24
 - Discharging current limit [A] : 1.1.2.25
 - Charging current limit [A] : 1.1.2.26

NOTE : For multi-batteries systems, the settings have to be written for each battery (max. 5 batteries) ! All examples are given for battery 1. E.g. for enabling manual current limits on 3 batteries, write to 1.1.2.24, 1.2.2.24 and 1.3.2.24.

- Grid-side piloting, and PV injection limitation:
 - Change the grid-side power consigns for more control and low-level piloting on the grid, e.g. force injection of a given power.
 - One setting for the grid AC input, by default 0W (minimization of grid exchanges): Target active power per phase [W] : 2.1.5.121 (consumption, so inject if negative value)
 - Note : Can lead to emptying the battery into the grid (prohibited in some countries) !
- Change injection limits on grid side :
 - Use case : Limitation of injection by good weather in case of energy excess in the grid
 - One setting per phase on the Grid AC input: Max sinked active power (injection) [W] : 2.1.6.10 (L1) / 2.1.7.10 (L2) / 2.1.8.10 (L3)

6.4.5 Example of control of next3 in function of an external smartmeter

In this example the power of the next3 is controlled in function of external measurement.

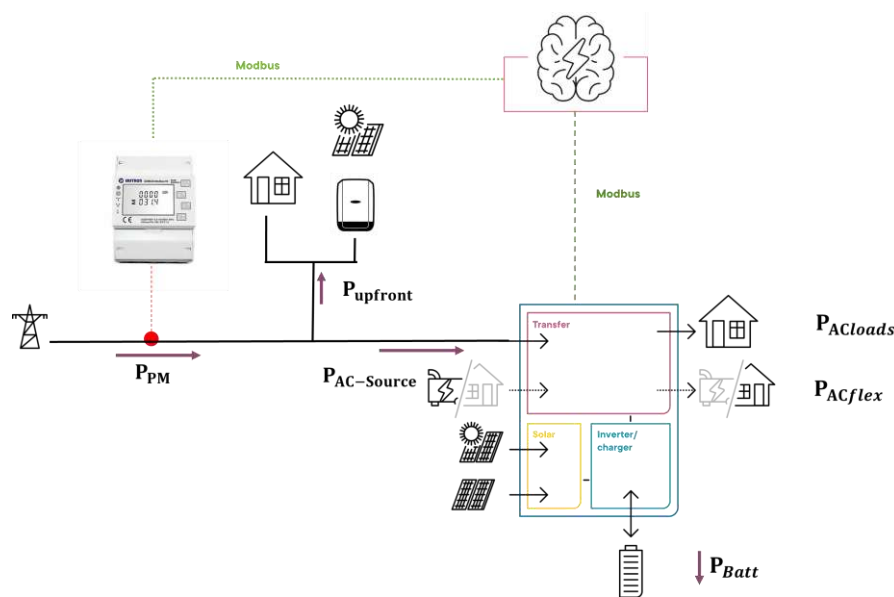

The power $P_{AC-Source}$ could be controlled using either:

- By setting "Use triphase target active power" to True (True by default), ID 2.1.5.120. Modbus register 1429 to have a global target power and by setting "Target active power per phase", ID 2.1.5.121, Modbus register 1430 to the desired value (Default value is 0W: if there is energy for load in the battery or space for solar energy the nx3 tries to take nothing on its AC-Source). Per example if you want to take globally 3kW on the AC-source, set 1kW for the register 1430.
- or by setting "Target sourced active power" if the power of each phase should be controlled individually, ID 2.1.6.13, 2.1.7.13, 2.1.8.13 and Modbus registers 1822, 2122, 2422. If the individual phases control is wanted the phase balancing should be disabled (ID 2.1.5.149). The external control must make it's own balance for each phase.

Here is an example of a simple control algorithm with the goal to maximise the overall self-consumption by minimizing the power taken from the grid:

1. Reads the power of the smart meter P_{SM} and the $P_{AC-Source}$ (ID 2.1.1.16. Modbus register 8). Then $P_{upfront}$ could be computed as follows: $P_{upfront} = P_{SM} - P_{AC-Source}$
2. Write the desired $P_{AC-Source}$ with one of the two methods presented above (tri-phased value or value for each phase)

$$P_{AC-Source} = P_{GridSetpoint} - P_{upfront}$$
 $P_{GridSetpoint}$ is the desired power taken from the grid, zero in this example.
3. Wait a certain time (depending on the wanted control loop frequency, 1s could be a good choice) and go back to the point 1.

The nx PowerFlowDispatcher keeps working normally, so the behaviour related to the SOC for backup/gridfeeding, the maximum charge/discharge current of the batteries or the nx solar priority are not altered. In the case of a such limit (e.g. maximum charging current) is reached, the real $P_{AC-Source}$ could be different as the one written by the control algorithm.

This way of controlling the nx system would also works fine with more complex systems (several nx3 and several batteries) and most of the complexity of the power flow management is smartly handled by the next PowerFlowDispatcher, keeping the external control algorithm as simple and easiest as possible.

6.4.6 Example of control for dynamic electricity prices

In some countries the electricity price is varying hour by hour. That is the case in Spain per example with the PVPC tariffs scheme.

The next3 could be controlled in function of the prices or simply by hours of the day by playing with the charge and discharge currents in function of the time of the day.

The control variable are:

- Maximal charging current limit: ID 1.1.2.26, Modbus register 334
- Maximal discharging current limits: ID 1.1.2.25, Modbus register 332

Manual current limits must be enabled once, per example manually at commissioning.

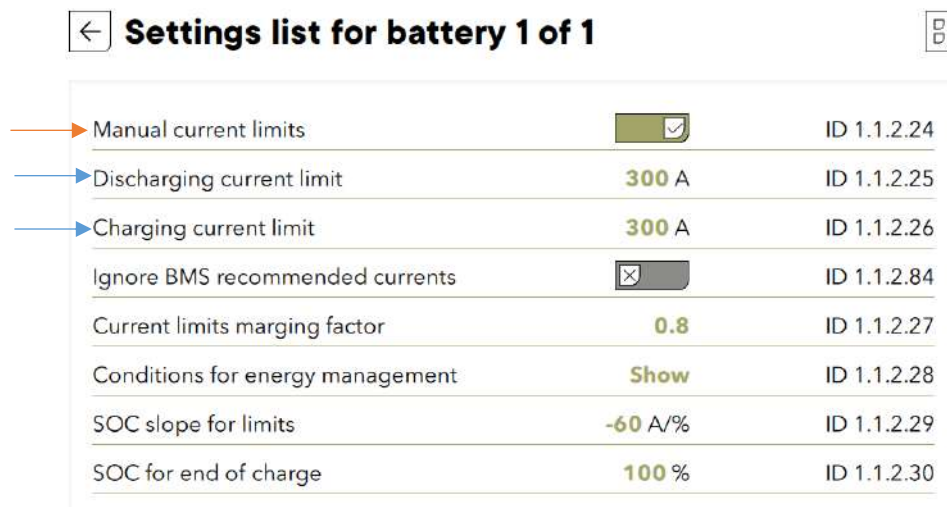

Setting	Value	ID
Manual current limits	<input checked="" type="checkbox"/>	ID 1.1.2.24
Discharging current limit	300 A	ID 1.1.2.25
Charging current limit	300 A	ID 1.1.2.26
Ignore BMS recommended currents	<input type="checkbox"/>	ID 1.1.2.84
Current limits margining factor	0.8	ID 1.1.2.27
Conditions for energy management	Show	ID 1.1.2.28
SOC slope for limits	-60 A/%	ID 1.1.2.29
SOC for end of charge	100 %	ID 1.1.2.30

And to control more freely the interaction to the grid:

- The delta P on AC-source per phase: Target active power per phase ID 2.1.5.121, Modbus register 1430
 - By default, it is 0 W and the next3 always try to minimize the exchange with the grid for maximum autarky. Per example with 2kW loads, if there is no solar and energy in the battery, the 2kW are discharged from the battery to try to have 0kW on the AC-source.
 - If the value is set to 1000W, each phase will try to take 1kW (3kW total). If there is 2kW loads, then 1 kW will be charged to the battery. If you say -1000W, then 5kW are discharged from the battery: 2kW for the loads and 3x1kW for injecting back to the AC-source.
 - Warning: with this, energy from the battery can be discharged to the grid and in some countries that is not allowed.

An example of control, available on demand, was done in python:

- A day program/profile is given in a simple csv file. Only 24 lines for the 24hours of the day in a given format.
- The python program reads that csv file and controls the nx3 over modbus TCP locally (within the LAN).
- The goal of this planning was that the next3 doesn't charge the battery as soon as there is solar excess. With dynamic pricing, in the morning the energy has generally more value than in the afternoon when there is a lot of solar production everywhere on the grid.
- For this a small charge current (5A) is set in the morning from 7h to 11h in the csv file. The battery is not charged in the morning and then the solar goes to the grid. Charging is allowed in the afternoon with a higher charge current. There is 50A allowed between 11 and 12h and then 100A.

The result is what was expected:

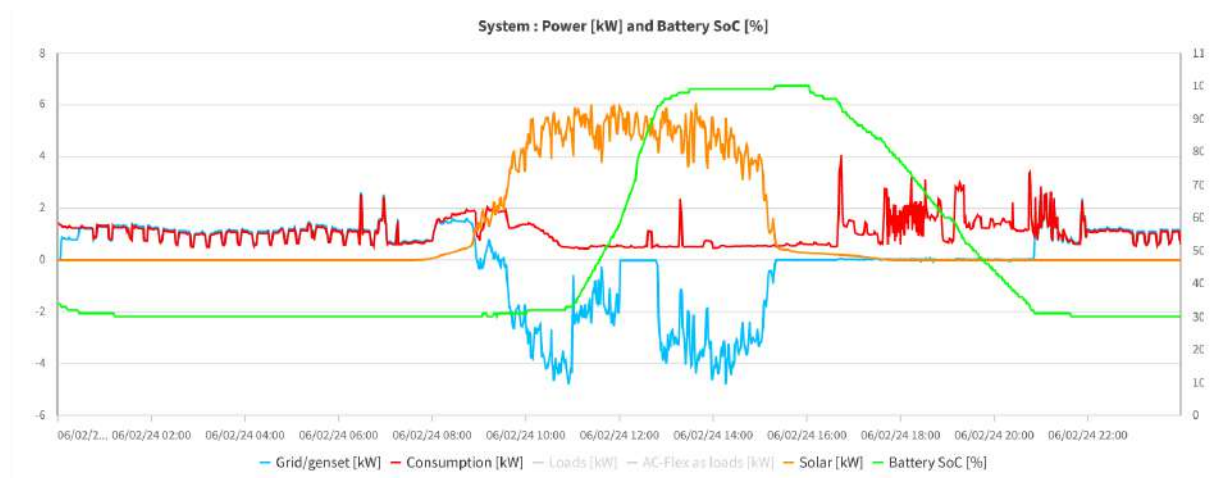

The max charging and discharging setpoints used can be seen on the monitoring portal with the display of the charging limits. (mixed with the setpoints from the BMS), so there is a kind of datalog of what is sent:

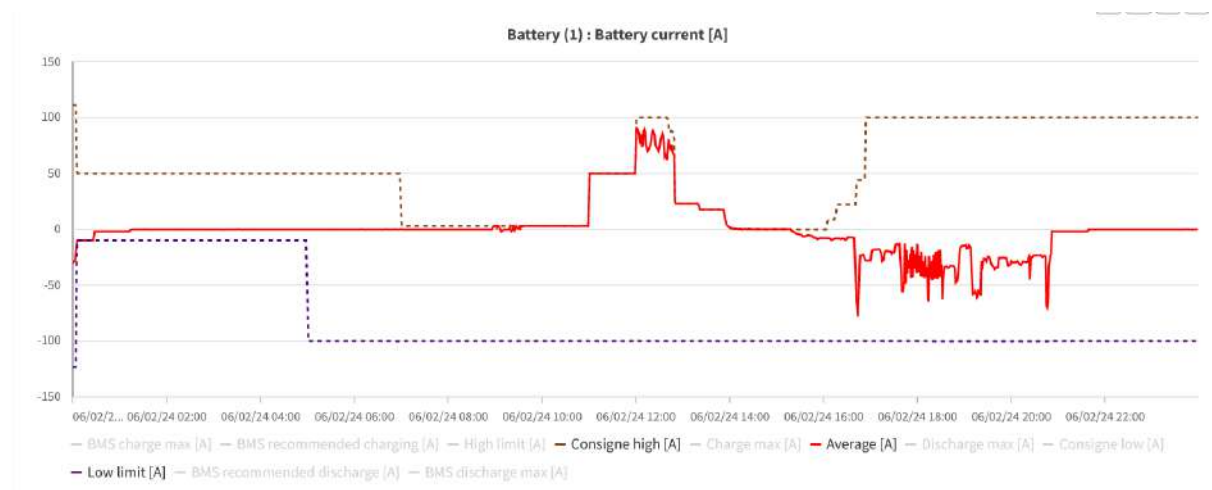

7 Maintenance of the installation

The nx-interface does not require any maintenance except updates of the software to have the latest version.

7.1 Software update

The procedure for the next3/next1/nx-interface software update is described here.

	<p>The USB key presence is mandatory even for the internet update, as the update files are copied on the USB key.</p>
--	---

First determine in which case you are. The internet connection and recent versions of the next3 allows for an easier update of the system. Systems with old versions or without internet connection requires the use of the USB memory stick.

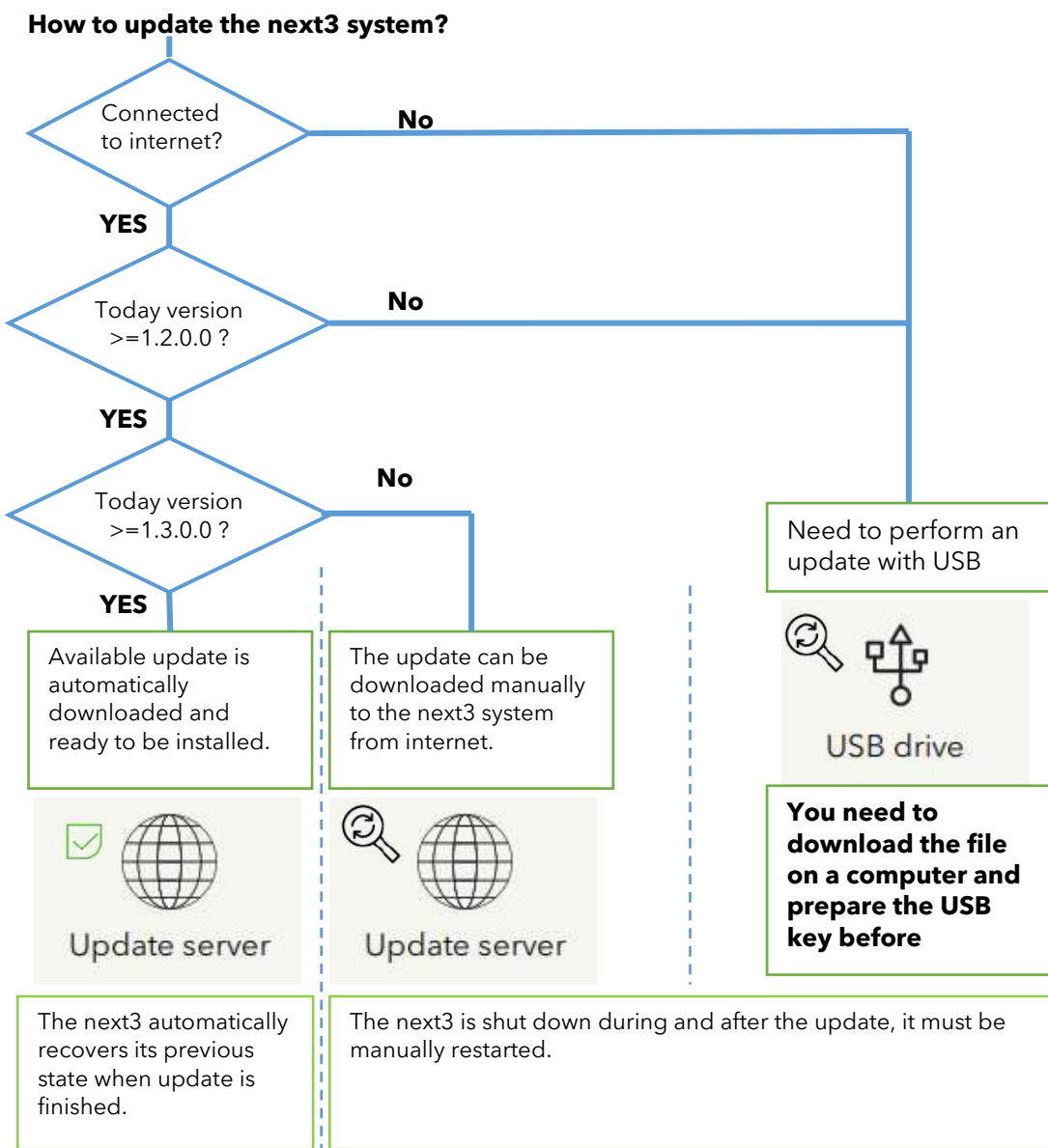

The update page in the nx-interface is where the update of the nextOS system (inverters, nx interface and accessories) is done. Go to the update page on the nx-interface:

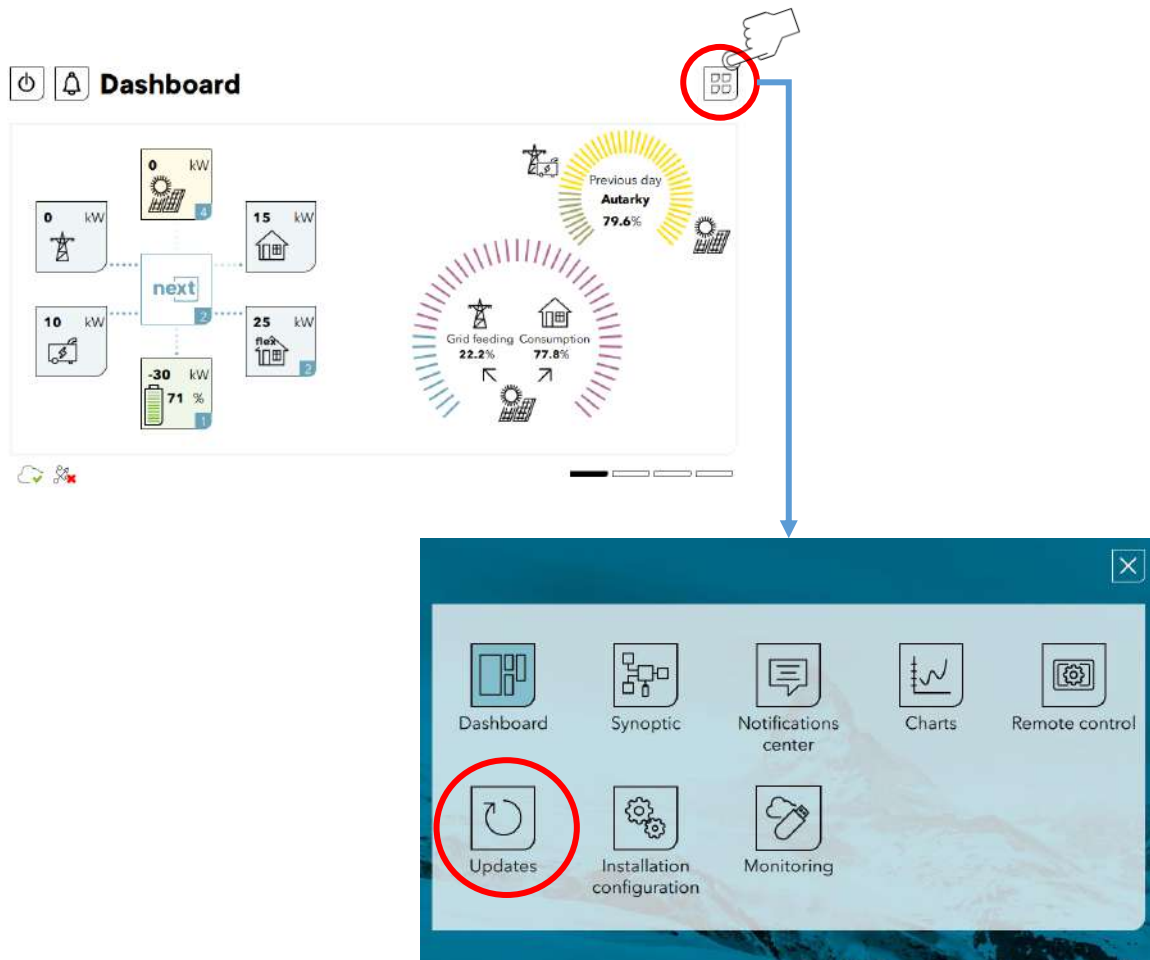

When you are in the update page different cases are possible according to the charge above:

7.1.1 Automatic update download (from version 1.3.0.0)

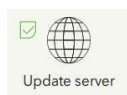

If an update is available, simply click the "start update" button. The check for new update is done once a week. If you are informed that there is a new version available before the automatic search, it is always possible to click the search button to check the update server at that time.



7.1.2 Non-automatic update download (from version 1.2.0.0)



Click the "Search" update button and then when the update is available, click the, "start update" button.



7.1.3 USB key update (older versions or without internet)



Download the latest software version from the download center in our website: <https://www.studer-innotec.com/en/downloads/> . Go to the next3 section and download the "software update". Unzip the file and copy the "next_vX.Y.Z.A.stub" file on an USB key at the root of the key.

Insert the USB key in the nx-interface. There must be only one USB key in the nx-interface. If there was already one, you should eject it before.

After a check, the interface will identify if an update is available. The current (in black) and the available update (in green) can be seen on the right side. Information will be displayed in case of software incompatibility. If there is no update available, you can click "Search USB" to confirm if the update file is on the USB unit. When an available update appears in green, click the "start update" button.



7.1.4 During and after the update:

You will see a message to inform you that the system will restart during the update procedure. Please be aware that the next3 will turn off and on during the update process. The update is performed in several steps. First, the nx-interface is updated and restarted. Once the next interface update is finished the update of the other devices in the system is also performed subsequently and automatically. The full process takes a few minutes.

In older version, the update is performed in many steps: first the nx-interface is updated and then you must press again on the "start update" button again for the next3 devices. After version 1.1.0.0 all is performed automatically.

If you update from version 1.3.0.0 or later to a higher version. The next3 will recover its initial state, that means the inverter will restart automatically if it was ON before launching the update. In any case there is a short interruption of the power supply to the AC-loads. It will be OFF after the update if it was already stopped before the update.

Before version 1.3.0.0, the next3 is always stopped for the update and a manual start with the front button (2 seconds), or the "ON/OFF" button in the nx-interface is necessary.

Note: The USB key must not be removed until the end of the updating process. If for some reason the updating process is interrupted, please restart it, and make sure to let the process finish.

7.1.5 Troubleshooting: update menu not available

If this menu is not available, that means the user level is not appropriate. The interface is in "View Only" mode and need to be changed to "Basic" or "Expert". The installer probably set the interface to that level to avoid unwanted modification of the system.

The modification of the user level is done with codes in the nx-interface, in the remote-control

screen and then on the configuration menu ( →  → )

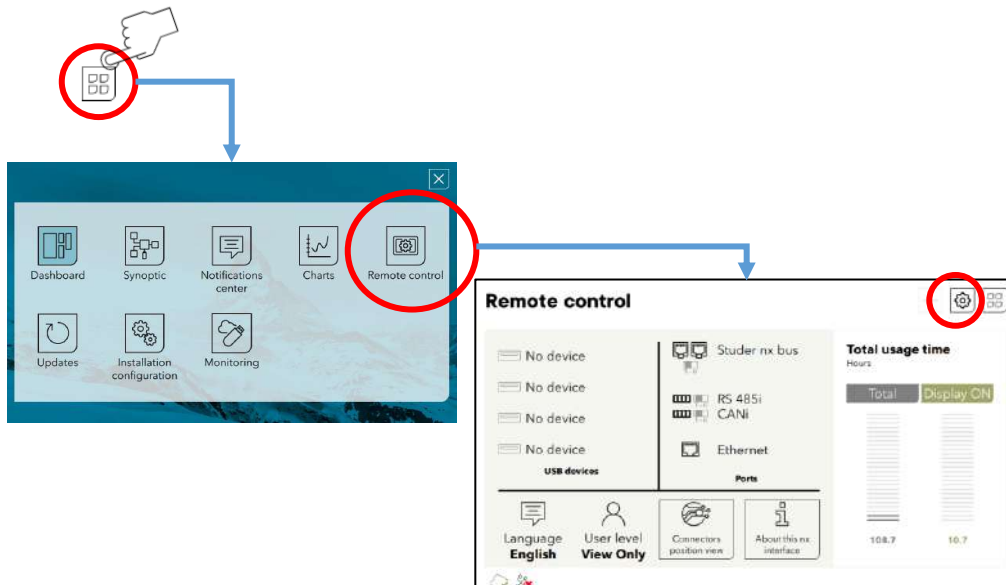

The codes are:

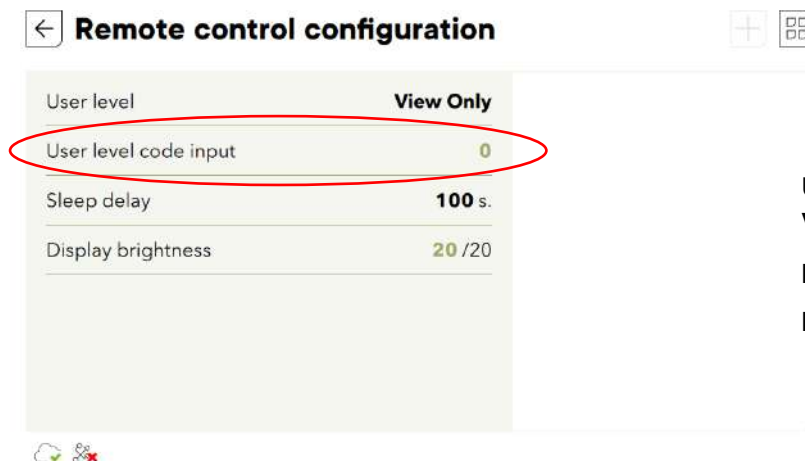

User codes:
View Only: 000000
Basic: 815566
Expert: For professionals only !

8 Nx-interface technical data

Consumption: 5W
 Power supply: exclusively with nx-bus directly from the nx1 or nx3.
 Weight: 0.8 kg

8.1 Mounting of the nx-interface

The nx-interface can be fixed on the nx3 inverter with dedicated mounting frame on the next3 or remotely wall mounted. It can also be integrated on a control panel.

The wall mounting can be done with two screws. The head of the screw goes in the dedicated slot on the back of the nx-interface.

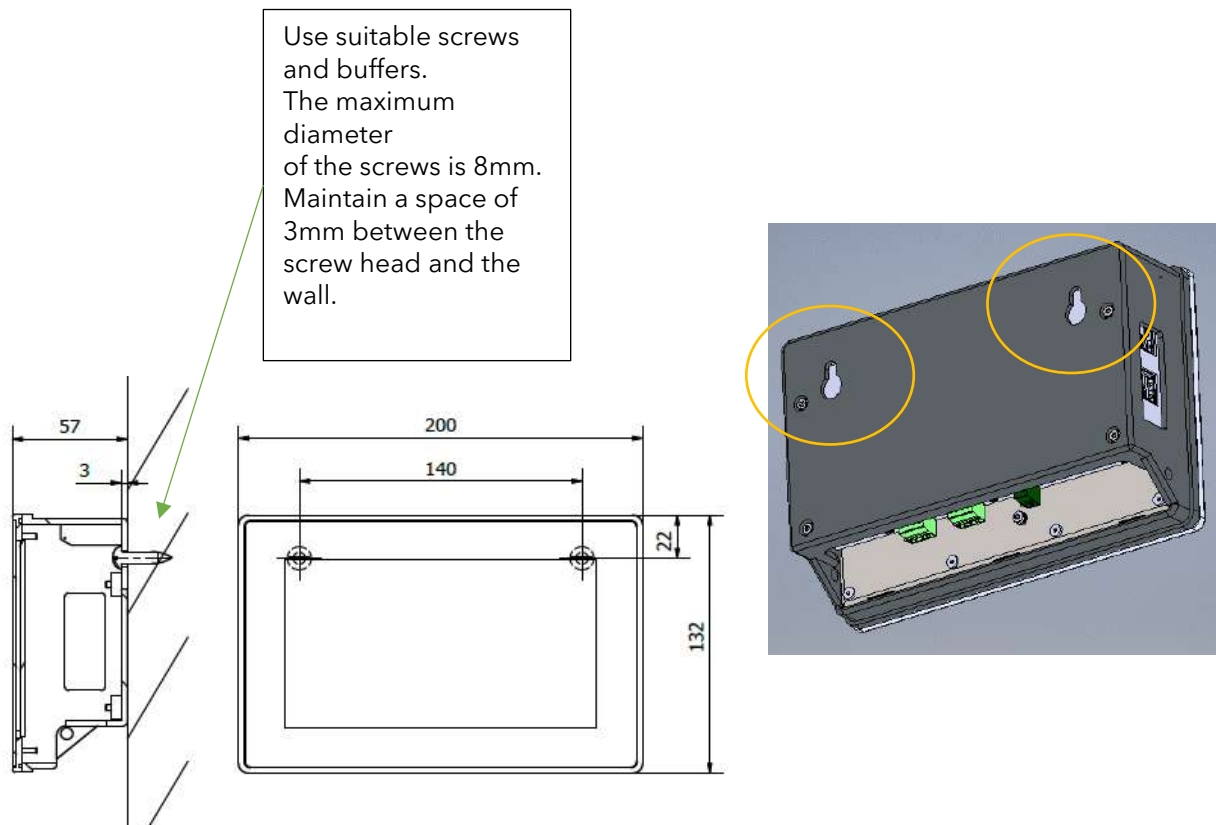

	<p>nx-interface is supplied with a 1m communication cable to mount on the device.</p> <p>Cables of different lengths (3m, 10m and 50m) can be ordered. Item reference is: <i>nx-ethernetCab 3m/10m/50m</i>. The length in meters is specified in reference.</p> <p>You can buy your own ethernet cable for communication; it must be ethernet cat5 with 26AWG. The maximal distance between the inverter and the nx-interface depends then on the rest of the cabling. The total communication cable length in one system for the Studer-nx-bus is 75m.</p>
--	---

On the next3, the nx-communication cable goes in the plug on the left of the nx interface and is easier to install before the mounting on the nx device. The ethernet cable (LAN) goes on the right.

See the wiring sections for details.

8.1.1.1 Panel mounting

The nx-interface can be integrated into a panel. The maximum thickness of the panel cannot exceed 4mm.

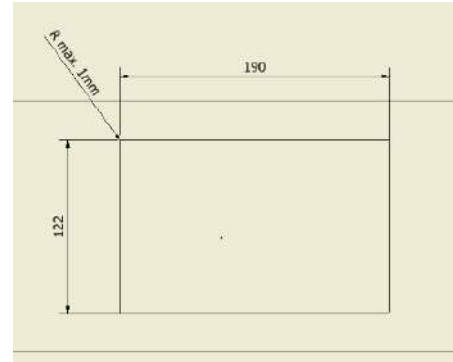

The opening cut in the front panel must be 122 x 190mm with a maximum radius of 1mm in the corners.

Mounting Instructions:

- Insert the device from the front into the cut-out of the panel and push it carefully until it is fully inserted.
- Insert the mounting elements (1) into the provided lateral T cut-outs (2) and push them sideways (3) so that they are locked.
- For the first mounting elements in a corner, tighten the fixing screw (4) until it presses on the plate. Tighten the fastening screws to a maximum torque of 0.2 Nm.



- Repeat procedure 3 for opposite mounting elements.
- Repeat procedure 3 for remaining mounting elements.

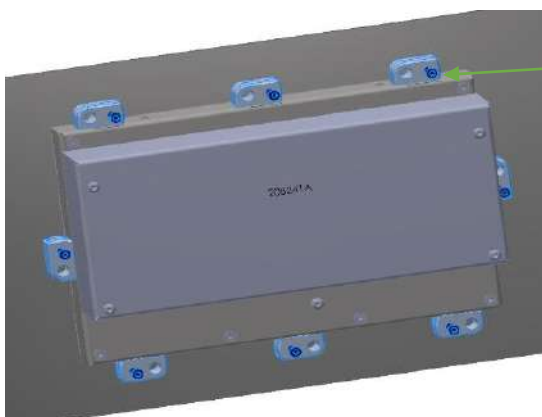

Mounting elements and screw are provided

Observe the maximum tightening torque of the fastening screws of the mounting elements otherwise they may be damaged.

Tighten the fastening screws of the mounting elements to a maximum Torque of 0.2Nm.

9 Product recycling

The nx-interface meets the European directive 2011/65/EU on hazardous substances and does not contain the following elements: lead, cadmium, mercury, hexavalent chrome, PBB or PBDE.

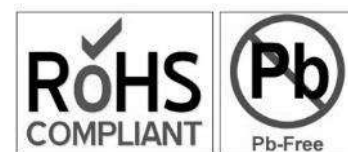

To dispose of this product, please use the service for the collection of electrical waste and observe all obligations in force in the place of purchase.



10 Conformity

The nx-interface described in this manual has been designed and manufactured in accordance with the following European directives:

- Low Voltage Directive (LVD) 2014/35/EU, including EN62368-1:2014/AC:2015 and EN60950-1
- Electromagnetic Compliance (EMC) Directive 2014/30/EU
- Restriction of use of certain Hazardous Substances (RoHS) Directive 2011/65/EU

Official up to date EU declaration of conformity (DoC) can be found on our website www.studer-innotec.com as well as some certifications performed by external accredited certification bodies.

10.1 Notes on grid codes

For the conformity and grid code conformity of the inverters nx3 and nx1 themselves, please see their respective manual.

The grid code is selected during the commissioning with the wizard. To be compliant the installer must not change any individual settings concerning grid code later. The **modification of grid code or individual settings concerning that subject is protected by a user code EXPERT given only to professionals.**

Scans of grid code certification test result are available on the product page and the certification can be found on the product documentation webpage: <https://technext3.studer-innotec.com>
Each country requirement is described on the page about compatibility: <https://technext3.studer-innotec.com/compatibility#2.-Grid-code-compatibility>