



USER MANUAL



Residential Hybrid Inverter

ELS3K, ELS3K6, ELS4K, ELS4K6, ELS5K, ELS6K

Table of Contents

Preface	1
Disclaimers	3
Important Safety Instructions	4
1 Product Introduction	10
1.1 Overview	10
1.2 Appearance	11
1.3 Dimension	12
1.4 Naming rules	12
1.5 Application scenarios	13
1.6 Electrical schematic	14
1.7 Supported grid types	14
1.8 Working modes	15
1.8.1 Self consumption mode	15
1.8.2 Economic mode	15
1.8.3 Time-of-use mode	16
1.8.4 Peak shaving mode	17
1.8.5 Emergency power supply mode	17
2 Installation	18
2.1 Precautions	18
2.2 Installation flow	18
2.3 Checking before installation	18
2.3.1 Check packing	18
2.3.2 Check accessories list	19
2.4 Installation tools	19
2.5 Installation environments	19
2.6 Installation angle	20
2.7 Installation space	21

2.8 Moving the inverter	22
2.9 Installing the inverter	23
3 Electrical Connection	24
3.1 Safety precautions	24
3.2 Circuit diagram	25
3.3 Recommended circuit breaker size	27
3.4 Port cable description	29
3.5 Connecting the ground cable (PE)	30
3.6 Connecting the PV cable	31
3.7 Connecting the battery cable	32
3.8 Connecting the Load and Grid cable	33
3.9 Connecting the COM cable	34
3.9.1 BMS/NTC	34
3.9.2 Meter/CT	36
3.9.3 COM1/COM2	40
3.9.4 WiFi/GPRS com. port	44
3.9.5 Parallel connection port	46
3.9.6 AFCI setup	47
4 Indicator	49
5 Commissioning	50
5.1 Check before powering on	50
5.2 Initial power on (Important)	50
5.3 APP settings	51
6 Troubleshooting and Maintenance	52
6.1 Inverter powering off	52
6.2 Inverter dismantling	52
6.3 Troubleshooting	52
6.4 Routine maintenance	60

6.5 Inverter disposal	60
7 Technical Specifications	61

Preface

1. Attention

The products, services or features you purchase are subject to the company's commercial contracts and terms. All or part of the products and service features described in this document may not be within the scope of your purchase. Unless otherwise agreed in the contract, the company does not make any express or implied statements or warranties regarding the contents of this document. Please keep the manual properly.

As an important part of the device, you can print the electronic user manual into paper as needed, and keep the paper and electronic documents properly for future reference. Anyone operating the device at any time must operate in accordance with the requirements of this manual.

2. Copyright declaration

The copyright of this manual belongs to EPEVER. No corporation or individual may plagiarize, partially or fully copy (including software, etc.), reproduce or distribute it in any form or by any means. EPEVER reserves the right of final interpretation. This manual may be updated based on user or customer feedback. Please visit our website www.epever.com for the latest version.

3. Overview

Please read the user manual carefully before installation, operation and maintenance. This manual contains important safety and installation instructions, which must be followed during equipment installation and maintenance.

4. Applicable products

This user manual describes the installation, electrical connection, commissioning, maintenance and troubleshooting of the ELS series residential hybrid inverter (hereinafter referred to as "inverter"). The ELS series includes the following product models:

ELS3K, ELS3K6, ELS4K, ELS4K6, ELS5K, ELS6K

5. Intended audience

This manual is only intended for professionals who are familiar with local regulations, standards and electrical systems, have received professional training, and know the product well.

6. Symbols in this manual

To ensure the user's personal and property safety during operation, as well as the efficient use of this product, relevant safety instructions are provided in the manual and highlighted with the corresponding symbols. To prevent personal injury and property damage, please fully understand and strictly follow these highlighted information. The symbols used in this manual are as follows.

 **DANGER**

Indicates a high-level hazard that, if not avoided, will result in serious injury or death.

 **WARNING**

Indicates a medium-level hazard that, if not avoided, could result in death or serious injury.

 **CAUTION**

Indicates a low-level hazard that, if not avoided, could result in minor or moderate injury.

NOTICE

Indicates an important reminder during the operation which, if ignored, may result in an equipment error alarm.

Tip

Indicates recommendation for reference.



Read through the user manual before any operations.

Disclaimers

The warranty does not apply to the following conditions:

- Damage caused by improper use or inappropriate environments (It is strictly forbidden to install the inverter in the flammable, explosive, dust accumulative or other harsh environments).
- The actual current/voltage/power exceeds the limit value of the inverter.
- Damage caused by working temperature exceeding the rated temperature range.
- Electric arc, fire, explosion and other accidents caused by failure to follow the inverter labels or manual instructions.
- Unauthorized disassembly and maintenance of the inverter.
- Damage caused by force majeure such as lightning strikes, rainstorms, mountain torrents and grid failures, etc.
- Damage occurred during transportation or loading/unloading the inverter.

Important Safety Instructions

Please keep this manual for future reference.

This manual contains instructions on safety, installation, and operation for ELS series residential hybrid inverter.

1. General safety instructions

DANGER

- The high voltage circuits in the inverter can endanger lives!
- Only professional electrical engineers can operate this product, minors and people with disability/mental illness cannot use this product. Do not install the inverter at a place within children's reach.

WARNING

- Ensure that the maximum AC input voltage and maximum photovoltaic (PV) output voltage (namely, the PV open circuit voltage after low temperature correction) does not exceed the maximum input voltage of the inverter. Failure to do so may result in inverter damage or other losses, for which EPEVER reserves the right to exclude warranty and shall not bear any joint liability.
- Due to the high temperature of the case when the inverter is running, be careful of being burned.
- When the inverter is running, only the display and buttons of the inverter can be touched.

NOTICE

The PV frame and bracket should be safely grounded in accordance with the local power department's grounding requirements!

2. Requirements for inverter installation

- Inverter must be installed in full compliance with national and local grid standards and regulations.
- Before proceeding with the installation and commissioning, read and understand all instructions contained in this manual, familiarize yourself with relevant safety symbols.
- In accordance with national and state/provincial regulations, access to the power grid is only permitted after obtaining authorization from the power department, and the operation must be performed by a qualified electrical engineer.
- Before installing and maintaining the inverter, cut off the DC power from the PV array and battery pack by the DC switch, as well as the AC power from the grid and generators by the AC

switch. Failure to do so may result in high voltage causing serious injury.

3. Requirements for professional and technical personnel

Installation, operation, maintenance, and replacement of devices or components are permitted only for qualified professionals or trained personnel. Personnel responsible for the installation and maintenance of device must undergo rigorous training, understand various safety precautions, and master correct operating procedures.



4. Transportation precautions

Upon leaving the factory, the inverter is already in its optimal electrical and mechanical condition. During transporting, it is imperative to use the inverter's original packaging or appropriate packaging to ensure the safety. Damage to the inverter caused during transportation is the responsibility of the shipping company. Upon pickup, please conduct a thorough inspection of the inverter. If any packaging issues are found that may cause damage to the inverter, or if any visible damage is found to the inverter, please immediately notify the responsible shipping company. If necessary, you can seek assistance from your PV system installer or EPEVER.

5. Assembly precautions

Assemble the inverter according to the details in the following sections of this manual. Place the inverter on an object (such as a wall or component bracket) with appropriate load-bearing capacity, ensuring it is placed vertically. Choose a suitable location for the installation of electrical equipment, ensuring sufficient space for fire escape routes to facilitate maintenance in case of failure. Maintain appropriate ventilation conditions to ensure adequate air circulation for cooling, with air humidity less than 95% during assembly.











6. Inverter label

		HYBRID INVERTER
Model:		ELS6K
PV INPUT		
Vmax.PV	580d.c.V	
MPPT Range	100d.c.V ... 550d.c.V	
Max.Current	16d.c.A x 2	
Isc.PV	19.2d.c.A x 2	
BATTERY INPUT		
Type	Lithium-ion/Lead-acid	
Voltage Range	42d.c.V ... 63d.c.V	
Max.Charging Current	120d.c.A	
Max.Discharging Current	120d.c.A	
GRID OUTPUT&INPUT		
Nominal Voltage	230a.c.V	
MaX.Current To Utility	26a.c.A	
MaX.Current From Utility	55a.c.A	
Rated Power To Utility	6000VA	
Frequency	50Hz/60Hz	
Power Factor Range	0.8leading-0.8lagging	
BACK-UP OUTPUT		
Rated Voltage	230a.c.V	
Rated Current	26a.c.A	
Rated Power	6000VA	
Frequency	50Hz/60Hz	
Output Power Factor	1.0	
GEN Data		
Gen Max. continuous current	26a.c.A	
Gen Rated Power	6000VA	
OTHER		
Operating Ambient Temp	-30°C ... +60°C	
Protective Class	I	
PV Inverter Topology	No-isolated	
Ingress Protection	IP65	
Overvoltage Category	II (DC), III (AC)	
IEC/EN 62109, IEC/EN 62477-1, IEC 62040-1		
		
HUIZHOU EPEVER TECHNOLOGY CO.,LTD. Add: No. 6 Laowu Road, Start-up Area of China-Korea (Huizhou) Industrial Park, Zhongkai District, Huizhou City, Guangdong Province, China		
MADE IN CHINA www.epever.com		

Labels must not be covered by unrelated objects (such as rags, cardboard boxes, equipment, etc.). Regular wiping is necessary to keep them visible at all times.

7. Explanations of symbols

The ELS series residential hybrid inverters come with some safety related labels. Ensure you carefully read and fully understand the labels before installing.

Symbol	Definition
	Residual Power Discharge Delayed discharge. Wait 5 minutes after power off until the components are completely discharged.
	Electric Shock Hazard The inverter contains fatal DC and AC power. All work on the inverter must be carried out by qualified personnel only.
	Beware of Hot Surface High-temperature hazard. Do not touch the product under operation to avoid being burnt.
	Caution Potential risks exist. Wear proper Personal Protective Equipment before any operations.
	CE Mark The inverter complies with the requirements of the applicable CE guidelines.
	Grounding Terminal Connect the inverter with grounding terminal to achieve grounding protection.
	Read through the user manual before any operations.
	Electrical Polarity Mark Pay attention to the polarity of the electrical connection.
	Temperature Mark Indicates the operating temperature range.
	Up Mark The inverter must always be transported, handled, and stored in such a way that the arrows always point upwards.

8. Electrical connection precautions

When handling energized inverters, comply with all current state regulations related to the prevention of electrical accidents.

DANGER

- All installation operations must be carried out by professional electrical engineers who have received training, thoroughly read this manual, and fully understood the relevant safety considerations.
- Ensure that the PV arrays are covered with opaque materials or the DC circuit breaker is disconnected before electrical connections. Exposure to sunlight will cause the PV array to generate dangerous voltages.
- When installing batteries, confirm the positive and negative terminals of the battery and ensure the battery is turned off.
- When connecting to the AC power, ensure that the breaker is disconnected.

NOTICE

The inverter can only be connected to the grid after obtaining permission from the local power department and ensuring all electrical connections are completed by a professional electrical engineer.

9. Operating precautions

DANGER

- Touching the terminals of the power grid or PV array, etc., may cause death from electric shock or fire!
- Do not touch terminals or conductors connected to the grid and PV circuit.

WARNING

Please wear protective gloves when operating the inverter as some internal components will heat up.

NOTICE

Pay attention to any instructions or safety documentation related to grid connections.

10. Maintenance precautions

DANGER

Before any maintenance, the electrical connection between the inverter and the grid should be disconnected first, followed by the disconnection of the DC side. Wait for at least 5 minutes until the internal components are fully discharged.

NOTICE

- The inverter can be restarted after removing the faults, which affects the safety performance. If any maintenance is required, please contact the local authorized service center.
- Unauthorized disassembly or alteration of components within the inverter is prohibited. Any losses caused by this will not be covered by the warranty or joint liability of EPEVER.

11. Inverter EMC Disclaimer

This equipment is designed to comply with Electromagnetic Compatibility (EMC) standards. However, electromagnetic interference (EMI) may still occur during operation due to factors such as installation environment, external devices, or other external conditions. The user is required to install and operate the device strictly in accordance with the provided instructions and to implement necessary measures to mitigate potential interference. The manufacturer shall not be liable for any interference issues resulting from improper installation, operation, or external environmental factors. For further assistance, please contact technical support.

1 Product Introduction

1.1 Overview

The ELS series is a single-phase photovoltaic (PV) residential hybrid inverter that integrates an on-grid PV inverter and battery, featuring an IP65 protection rating. With the various built-in working modes to meet users' diverse needs, it supports a combination of grid, oil generator, and solar charging, as well as the utility bypass output, independent inverter output, and energy management. Additionally, it supports parallel operation of multiple single-phase inverters for application expansion.

The inverter optimizes the PV output power to achieve self-consumption, feeding excess energy into the grid or storing it in batteries to reduce reliance on the grid and provides backup power during outages. The uninterrupted power supply (UPS) mode supports inductive loads such as air conditioners or refrigerators, with an automatic UPS level switch time of less than 10 milliseconds.

The ELS series inverter is applied to on-grid and off-grid solar power systems, integrating on-grid PV inverter and battery charging/discharging capabilities, offering a flexible solution for household electricity needs.

Features

- Integrated heat dissipation technology without fans, IP65 dustproof and waterproof rating
- User-friendly APP operation through the WiFi module
- UPS level switching within 10ms
- Maximum charging and discharging current up to 120A
- PV maximum input power up to 9,000W, support oversizing up to 1.5 times the rated power
- PV input voltage range from 100V to 580V
- PV maximum working current 16A plus 16A
- High standard protection on the DC side, including standard surge level 2 protection and optional AFCI function
- Independent generator interface for energy storage, intelligent load, and AC coupling management
- Comprehensive anti-reverse current function
- Up to 94.6% of maximum battery charging and discharging efficiency
- Multiple AC parallel function for more flexible system solutions
- Optional RS485/WiFi/GPRS modules for smart monitoring
- RSD rapid shutdown to reduce device damage and prevent personnel injury

1.2 Appearance

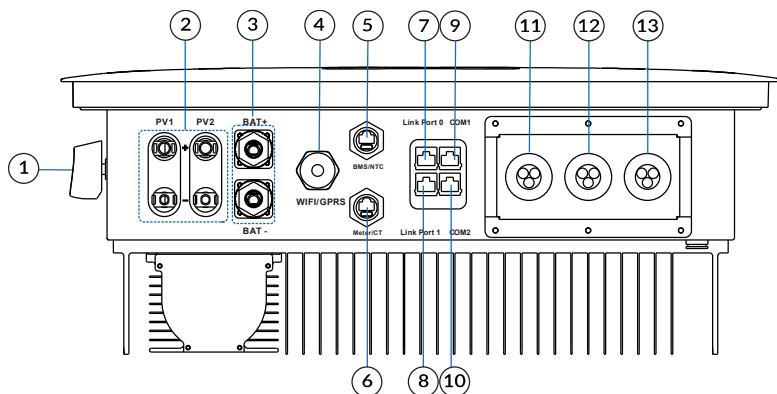

No.	Description	No.	Description
1	DC switch ⁽¹⁾	8	Parallel connection port 1
2	PV input terminals	9	COM1
3	Battery input terminals	10	COM2
4	WiFi/GPRS com. port	11	Generator connection port
5	BMS/NTC port	12	Load connection port
6	Meter/CT port	13	Grid connection port
7	Parallel connection port 0		

(1) Tightening the screw will restrict the rotation of the DC switch, preventing it from switching from OFF to ON or from ON to OFF. Only after removing the screw can the DC switch be rotated from OFF to ON or from ON to OFF. (Australia only)

- Details for ports 4, 5, 6, 7, 8, 9, 10 refer to Section 3.9.
- The grounding position of the inverter heat sink is shown in the figure below:

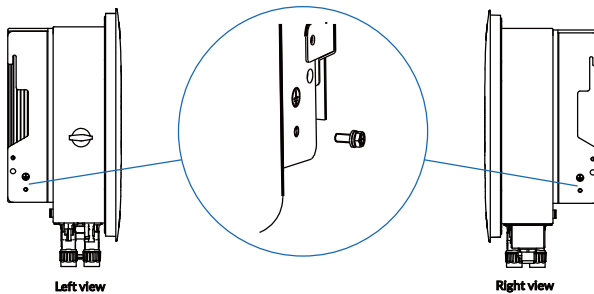

1.3 Dimension

Unit: mm

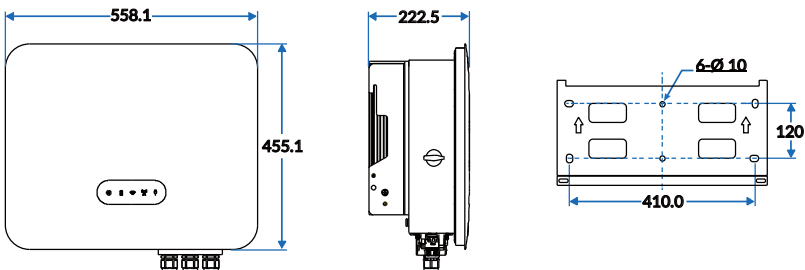

1.4 Naming rules

E L S 5K

- Rated output power: 3K6 means 3.6KW; 5K means 5KW
- Output voltage type: S means single phase; T means three phase; D means split phase
- Battery voltage level: L means low battery voltage; H means high battery voltage
- Inverter type: E stands for standard-alone energy storage inverter

1.5 Application scenarios

- Schematic diagram of single inverter connection

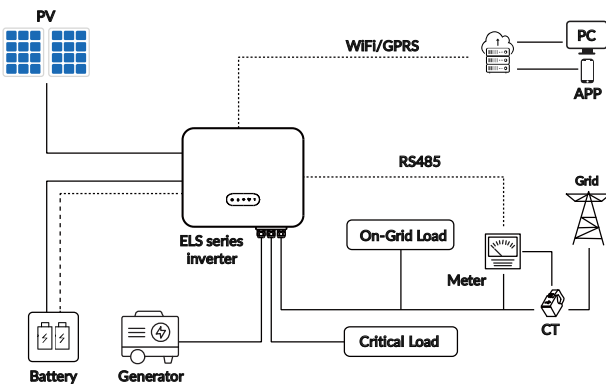

- Schematic diagram of multiple inverters connection

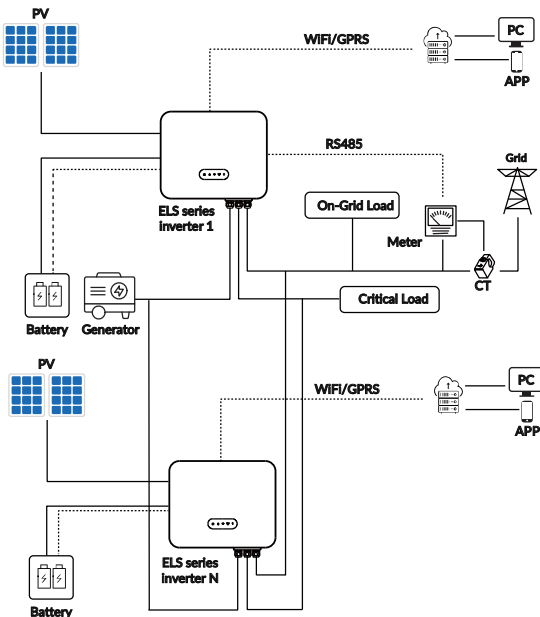

1.6 Electrical schematic

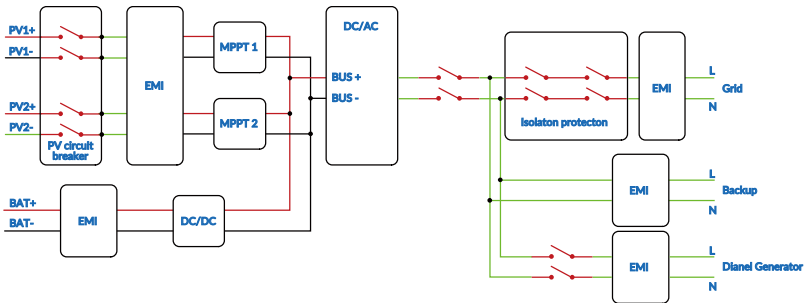

1.7 Supported grid types

The supported grid types for ELS series are TN-S, TN-C, TN-C-S, and TT. For the grid structure with N wire, the effective value of the voltage between the N wire and the PE wire must be less than 10V.

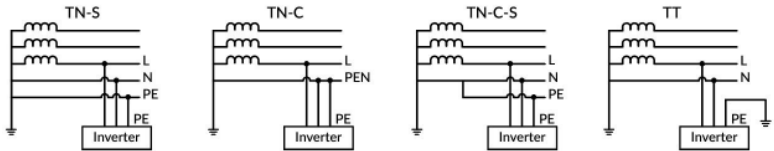

1.8 Working modes

1.8.1 Self consumption mode

Day time: When the power generated in the PV system is sufficient, it will supply the loads in priority. And the excess power will charge the batteries first. The remaining power will be sold to the grid.

When the power generated in the PV system is insufficient or no power is generated, the battery will supply the loads in priority. If the battery power is insufficient, then the load will be powered by the grid.

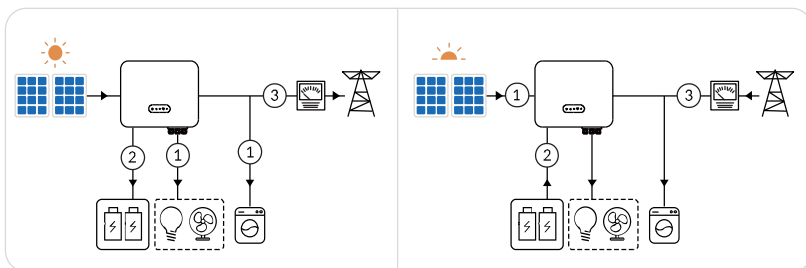

Night: If the battery power is sufficient, the load will be powered by the battery. If the battery power is not enough, the load will be powered by the grid.

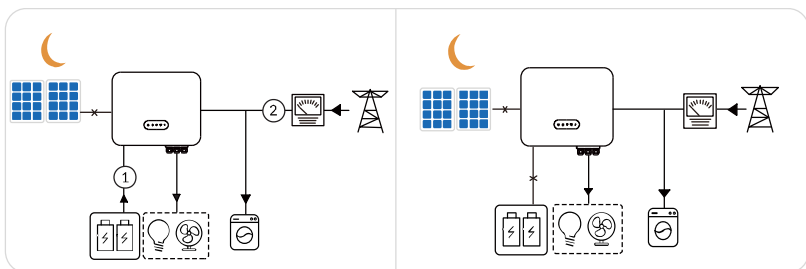

Scenario recommendation: It is suitable for areas with high electricity prices and little or no solar power generation subsidies.

1.8.2 Economic mode

Users can set the charging power based on their own electricity demand and price, enabling battery charging during periods of low electricity demand and switching to a self-consumption mode during high electricity demand periods. The stages of high and low electricity demand are divided by season, week, and time of day, with summer and winter primarily determining high and low demand, weekdays and weekends primarily determining electricity usage, and day and night

primarily determining electricity demand.

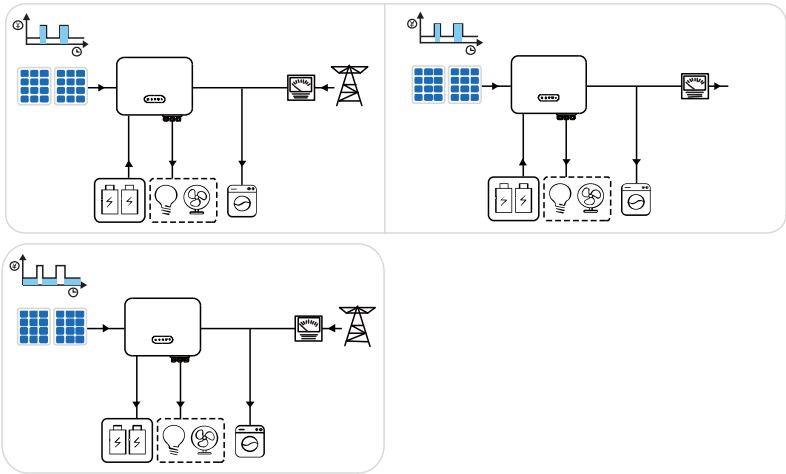

Scenario recommendation: Users with distinct high and low electricity demand, such as less electricity during weekdays and more on weekends, can set up battery charging at night on weekends. For example, if local summer PV generation significantly differs from winter, battery charging can be scheduled at night during winter.

1.8.3 Time-of-use mode

The system performs the charging and discharging according to the set charging/discharging period and power.

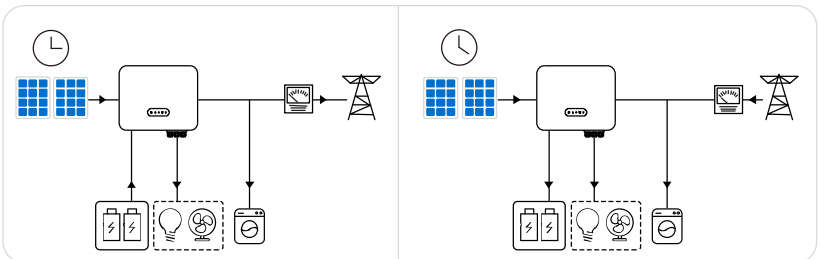

Scenario recommendation: It is suitable for scenarios when the peak-valley electricity price varies a lot, and it can only be used when local laws and regulations are met, such as whether the battery is allowed to discharge and sell to the power grid. When the electricity price is at its valley, set the time for the grid to charge the battery. When the electricity price is at its peak, the battery will

power the load first, and the remaining power can be sold to the grid. Thereby earning the corresponding profit from the grid price difference.

1.8.4 Peak shaving mode

Users can set the peak shaving power according to the actual need. During peak hours, the inverter limits the power supplied by the grid. The insufficient power is provided by PV and battery, reducing the local electricity consumption. During off-peak hours, the grid charges the battery, and supplies power to the load simultaneously.

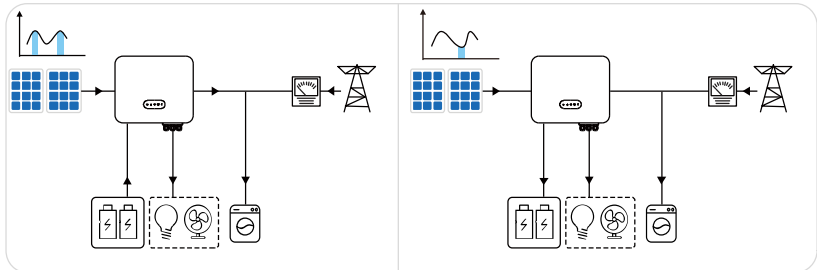

Scenario recommendation: Recommended for use in areas with high electricity consumption.

1.8.5 Emergency power supply mode

When the power grid is cut off, PV will supply the loads in priority; if the PV power generation cannot meet the load usage, the battery discharges to supplement. If the PV power generation exceeds the load demand, the surplus power charges the battery. When the battery runs out of energy, the system can switch to a diesel generator mode, and then the generator supplies power to the load.

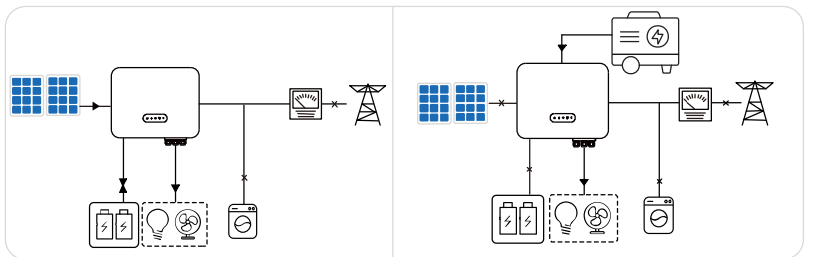

Scenario recommendation: Recommended for use in areas with unstable power grid.

2 Installation

2.1 Precautions

DANGER

- Do not install the inverter in a place near flammable, explosive, or corrosive materials.
- Do not install the inverter in a place that is easy to touch, especially within children's reach.

WARNING

High temperature exists when the inverter is working. Do not touch the surface to avoid burning.

CAUTION

When transporting and moving inverters, the weight of the equipment should be considered. Determine the installation position. At least two persons are required to install the inverter.

2.2 Installation flow

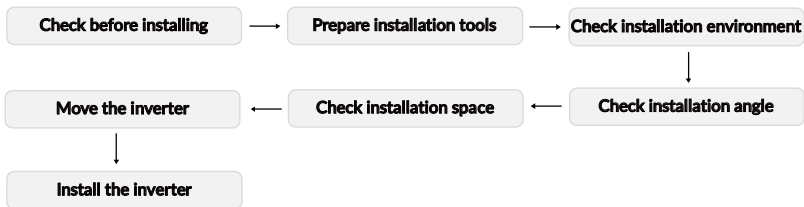

2.3 Checking before installation

Tip Please carefully check the product packaging and accessories list before installation.

2.3.1 Check packing

Packaging materials and components may be damaged during transportation. Therefore, before installing the inverter, please inspect its packaging materials. Check the packaging for any damage, such as holes, cracks, etc. If any damage is found on the inverter, do not open the package and contact your dealer as soon as possible. It is recommended to inspect the packaging materials within 24 hours before installing the inverter.

2.3.2 Check accessories list

After unpacking the inverter, inspect the product and its accessories to ensure they are complete and undamaged. If any parts are missing or damaged, please contact the dealer.

2.4 Installation tools

Prepare the following tools to install and connect the inverter.

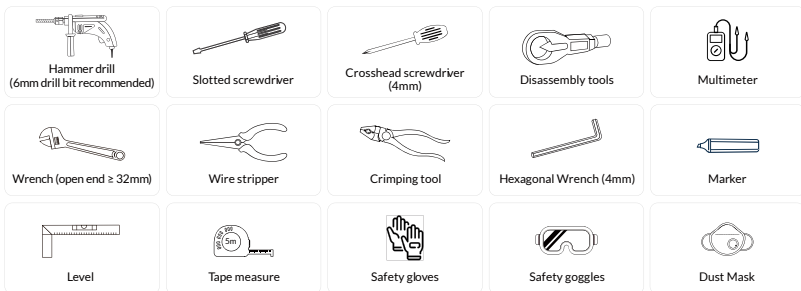

2.5 Installation environments

- The place to install the inverter shall be well-ventilated for heat radiation.
- Installation environment temperature range: -25°C to 60°C , relative humidity: 0 to 95% (non-condensing).
- Install the inverter in a sheltered place to avoid direct sunlight, as increased temperature may lead to reduced power output.
- It is recommended to choose a shaded installation site or construct a sunshade.
- Do not install the inverter in a place near flammable, explosive, or corrosive materials.
- The installation carrier must be fireproof; do not install the inverter on flammable materials.
- Ensure the installation surface is sturdy and meets the load-bearing requirements for the inverter.
- Do not install the inverter on the support with poor sound insulation to avoid the noise generated by the working product, which may annoy the residents nearby.
- The altitude to install the inverter must not exceed 4,000 meters.

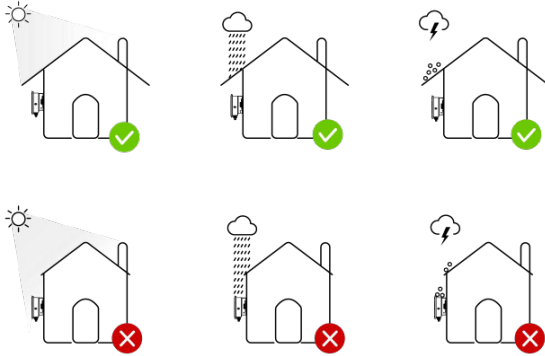

2.6 Installation angle

Inverter supports wall mounting and bracket mounting. Installation angle requirements are as follows:

- Install the inverter vertically or at a maximum back tilt of 15 degrees.
- Do not install the inverter in a tilted, horizontal, upside down, excessively backward-leaning, or sideways-tilted position.

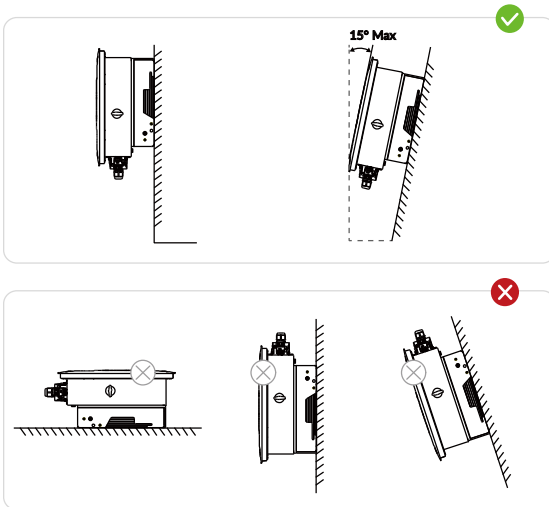

2.7 Installation space

When installing the inverter, a certain amount of space should be reserved to ensure that there is enough space for installation and heat dissipation.

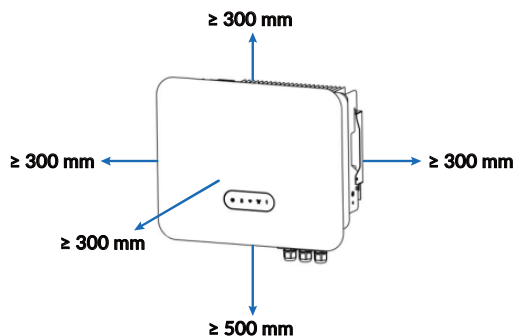

In scenarios with multiple inverters, a linear installation is recommended when space is sufficient; when space is limited, the following Triangle installation is recommended. It is not recommended to install multiple inverters in a stacked configuration.

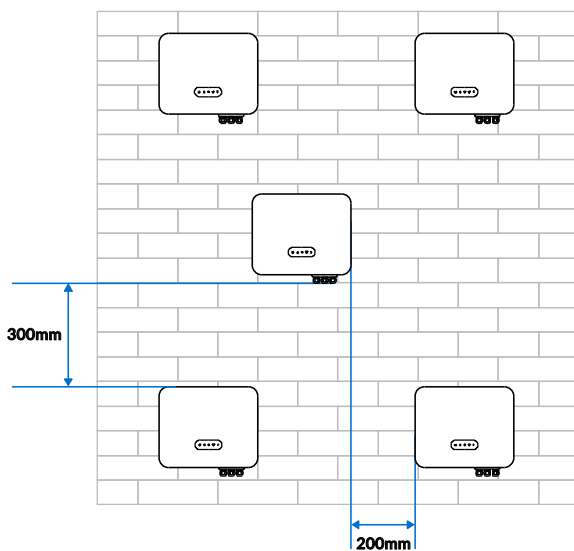

2.8 Moving the inverter

Step 1: Open the packing box, and two operators place their hands under the inverter's heat sink, lifting the inverter out of the packing box.

Step 2: Move the inverter horizontally to the designated site.

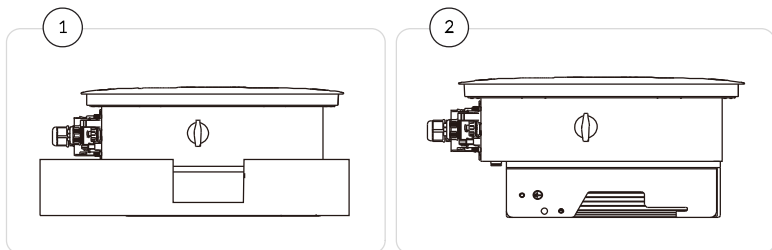

CAUTION

- Please maintain balance when moving the inverter to avoid dropping and injuring the operator.
- The power line and signal line interfaces at the bottom of the inverter cannot bear weight; do not let the terminal connectors directly touch the ground; place the inverter horizontally.

NOTICE

When placing the inverter on the ground, use foam or cardboard underneath to prevent damage to the casing.

2.9 Installing the inverter

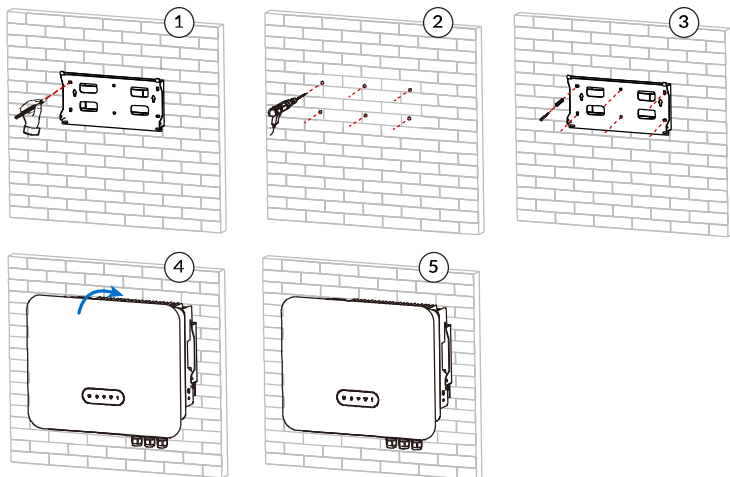

Step 1: Select a proper wall which meets the installation requirements. Put the mounting plate on the wall horizontally and mark positions for drilling holes. Then use an impact drill to drill holes in the wall (hole diameter 10mm). When drilling, keep the impact drill vertical to the wall, and the drilling depth slightly greater than the length of the expansion tube. After drilling, verify the hole positions with the mounting plate; if the deviation is too large, reposition and drill again.

Step 2: Slowly tap the expansion screw tube into the drilled hole with a hammer.

Step 3: Align the mounting plate with the holes, put shrapnel and flat pads, and fix the mounting plate with hexagonal nuts.

Step 4: Hang the inverter on the mounting plate and lock them with M6 Allen socket screws.

Step 5: To deter theft, users can configure an appropriate small lock to secure the inverter to the mounting plate (optional, the anti-theft lock needs to be purchased separately).

3 Electrical Connection

3.1 Safety precautions

Ensure that both AC and DC sides are not energized before installation and maintenance. Since the capacitor is still live for a period of time after the DC side of the inverter is disconnected, it is necessary to wait 5 minutes to ensure that the capacitor is discharged completely. The ELS series residential hybrid inverters are used in the PV energy storage systems. Improper use may damage the inverter.

DANGER

Before carrying out the electrical connections at the DC side, ensure that the PV panels are covered with opaque material or disconnect the circuit breaker at the DC side. If the PV panels are exposed to sunlight, the PV array will generate hazardous voltages.

WARNING

- The installation and maintenance of inverters must be carried out by professional electrical engineers. When working on high-voltage/high-current systems (such as inverters and battery systems), rubber gloves and protective clothing (including protective glasses and boots) should be worn.
- The open-circuit voltage of the PV modules connected to the ELS series inverter should not exceed 580V. The connected PV modules must have an IEC61730 Class A rating.

3.2 Circuit diagram

NOTICE

N and PE wiring via GRID and BACK-UP ports of the inverter are different based on the regulation requirements of different regions. Refer to the specific requirements of local regulations

Scenario 1: N and PE wires are bonded together in the distribution cabinet (applicable to areas in Australia, New Zealand, South Africa, and etc.)

The PE-N relay bonding function is not required to be enabled.

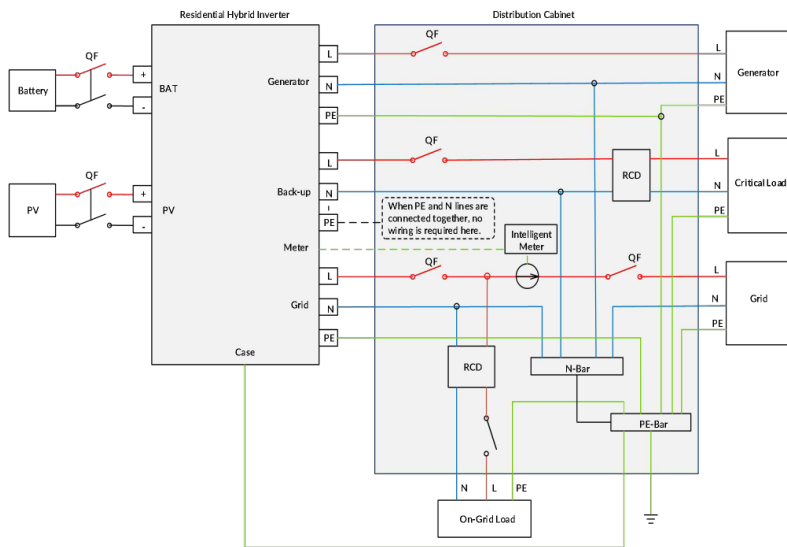

Scenario 2: N and PE wires are not bonded together in the distribution cabinet (applicable to areas except for Australia, New Zealand, South Africa, etc.)

According to local regulations, the energy storage system requires PE-N bonding, and the inverter's PE must be bonded to the distribution cabinet's PE. The ELS series residential hybrid inverters are equipped with a PE-N bonding function: when the inverter operates in off-grid mode, PE and N are bonded; when the inverter operates in on-grid mode, PE and N are disconnected.

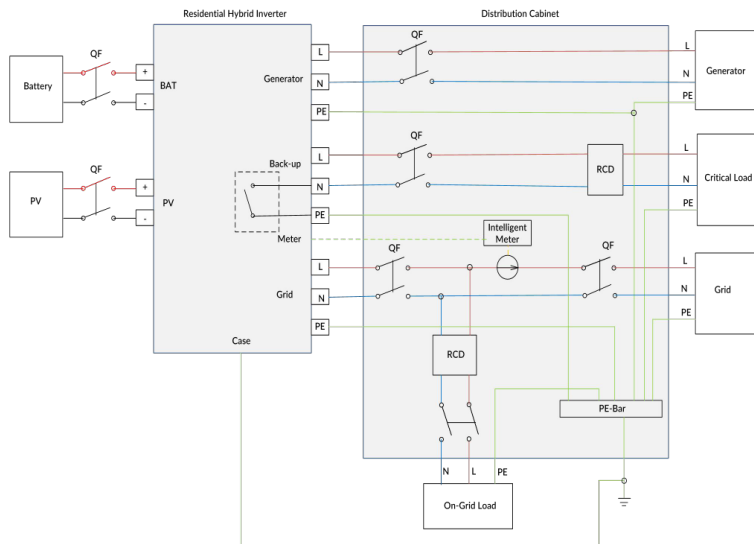

NOTICE

The PE-N relay bonding function is disabled by default. To enable this function, please operate on the APP. For details, please refer to Section [5.3 APP settings](#).

3.3 Recommended circuit breaker size

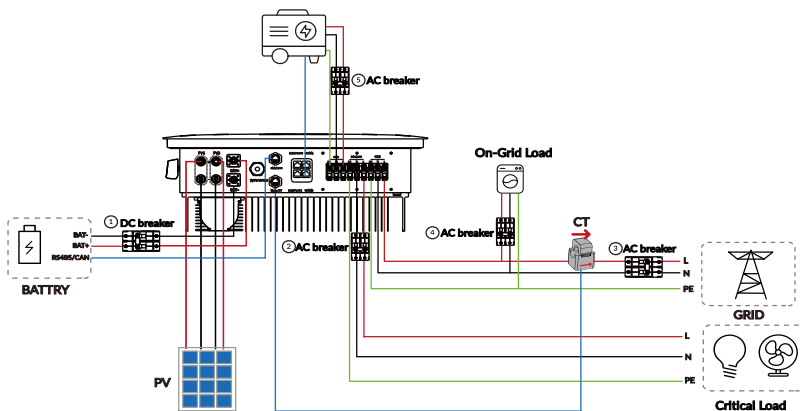

① DC breaker

Model	Rated Voltage	Rated Current
ELS3K	80VDC	100A
ELS3.6K		
ELS4K		
ELS4.6K		125A
ELS5K		160A
ELS6K		

② AC breaker

Model	Rated Voltage	Rated Current
ELS3K	400VAC	30A
ELS3.6K		
ELS4K		
ELS4.6K		40A
ELS5K		
ELS6K		

③ AC breaker

Model	Rated Voltage	Rated Current
ELS3K	400VAC	40A
ELS3.6K		50A
ELS4K		63A
ELS4.6K		
ELS5K		
ELS6K		







④ AC breaker

Model	Rated Voltage	Rated Current
ELS3K	400VAC	30A
ELS3.6K		
ELS4K		40A
ELS4.6K		
ELS5K		
ELS6K		

⑤ AC breaker

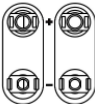
Model	Rated Voltage	Rated Current
ELS3K	400VAC	30A
ELS3.6K		
ELS4K		40A
ELS4.6K		
ELS5K		
ELS6K		

3.4 Port cable description

Port	Definition		Cable type	Cable specification
BAT +   BAT -	+: Connecting to the positive terminal of the battery.		Outdoor multi-core copper cable	25mm ² to 35mm ² (ELS3K, ELS3.6K)
	-: Connecting to the negative terminal of the battery.			30mm ² to 35mm ² (ELS4K, ELS4.6K, ELS5K, ELS6K)
PV1 PV2 	+: Connecting to the positive terminal of the PV array.		Outdoor multi-core copper cable	4mm ² to 5mm ² (All models)
	-: Connecting to the negative terminal of the PV array.			
	Load	L	Outdoor multi-core copper cable	6mm ² to 8mm ² (ELS3K, ELS3.6K)
		N		8mm ² to 10mm ² (ELS4K, ELS4.6K, ELS5K, ELS6K)
		PE		
	AC	L	Outdoor multi-core copper cable	10mm ² to 12mm ² (ELS3K, ELS3.6K)
		N		12mm ² to 16mm ² (ELS4K, ELS4.6K, ELS5K, ELS6K)
		PE		
	GEN	L	Outdoor multi-core copper cable	6mm ² to 8mm ² (ELS3K, ELS3.6K)
		N		8mm ² to 10mm ² (ELS4K, ELS4.6K, ELS5K, ELS6K)
		PE		

3.5 Connecting the ground cable (PE)

NOTICE

Since the inverter is non-transformer, it is required that both the positive and negative terminals of the battery and PV array cannot be grounded, otherwise the inverter failure will occur. In the PV power generation system, all non-current-carrying metal components (e.g. brackets, shells of combiner box/distribution cabinet, or inverter etc.) should be connected to the ground.

Step 1: Prepare a grounding cable (recommended to use yellow-green outdoor power cable with cross-sectional area $\geq 6\text{mm}^2$).

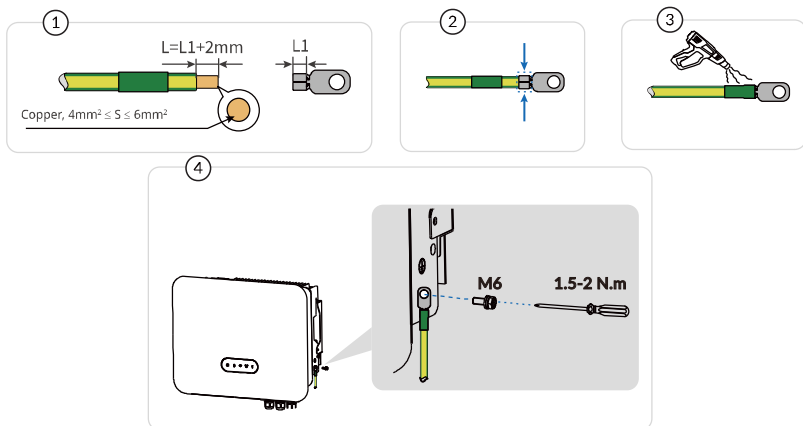

Step 2: Use wire strippers to strip the insulation layer of the grounding cable to a suitable length (as shown in Figure 1).

Step 3: Insert the stripped wire into the OT terminal and crimp it tightly with wire crimper (as shown in Figure 2. Recommended OT terminal model: OTM6).

Step 4: Secure the OT terminal with an M6 screw at the position shown in Figure 4. with a recommended tightening torque of 2 N.m.

NOTICE

The cavity formed by crimping the terminal's conductor crimp sleeve should completely enclose the cable, and the cable should be tightly secured with the terminal.

3.6 Connecting the PV cable

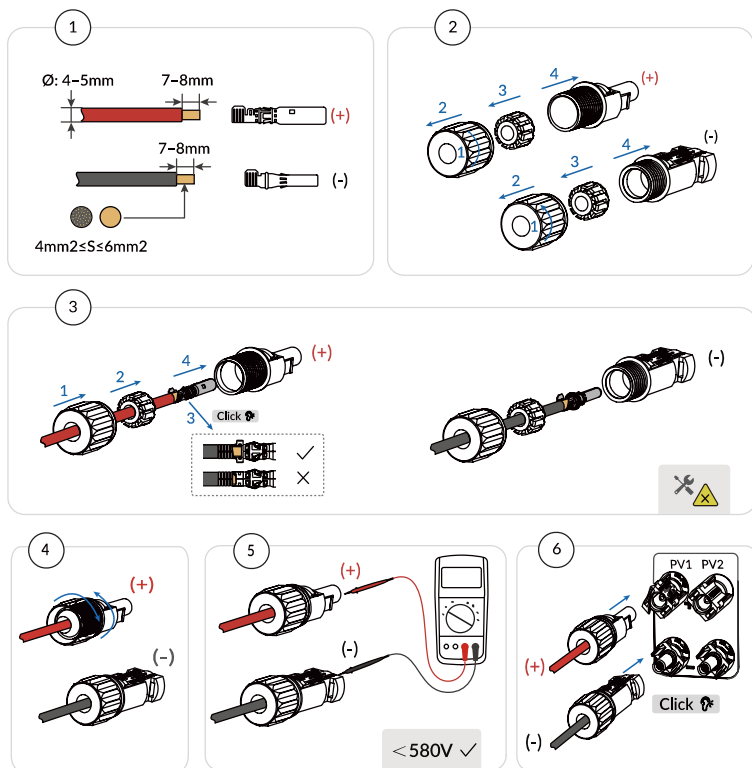

Step 1: Select the appropriate cable type and specification according to Section [3.4 Port cable description](#). And remove the cable connectors from the PV cables. It is recommended to differentiate the positive and negative terminals with different colors.

Step 2: Use wire strippers to strip the insulation layer of the PV cable to a suitable length (as shown in Figure 1).

Step 3: Insert the stripped cables into their respective positive and negative metal terminals. Use wire crimper to firmly press the cables, ensuring a secure connection between the cables and the metal terminals.

Step 4: Thread the crimped PV cables through the locking nuts, then insert them into its respective plastic housings until you hear a "click" sound, indicating that the metal cores are securely seated, after which tighten the locking nuts.

Step 5: Use a multimeter to check the positive and negative poles of PV cables, and then, connect them to the PV terminals of the inverter accordingly.

WARNING

Ensure the "DC SWITCH" has been rotated to "OFF" before removing the PV connectors.

NOTICE

If it is necessary to remove the PV connectors from the inverter, you can insert a removal wrench into the fixed latch and press down firmly to carefully remove the PV connectors.

3.7 Connecting the battery cable

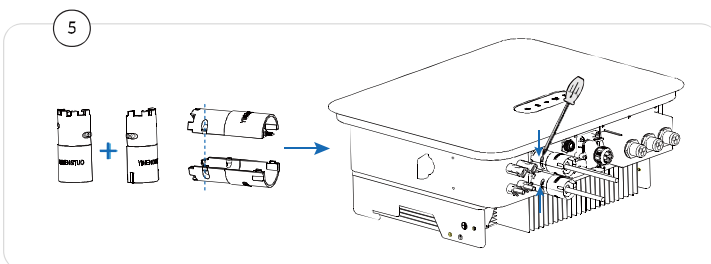
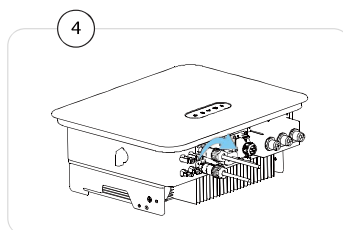
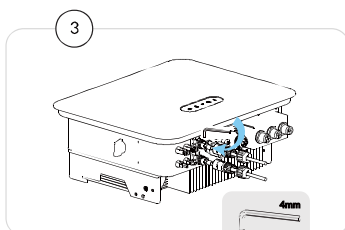
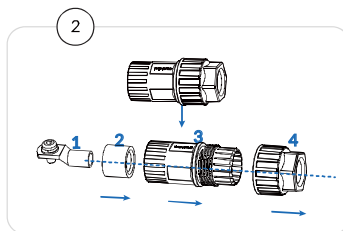
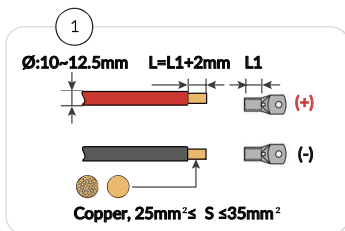

Step 1: Use wire strippers to strip the insulation layer of the battery cable to a suitable length (as shown in Figure 1).

Step2: Disassemble the battery connector.

Step 3: Thread the battery cable sequentially through the waterproof accessories 4/3/2 (refer to Figure 2 for details). And then, lock the OT terminal on the battery terminal of the inverter.

Step 4: Secure the waterproof accessories as shown in Figure 4.

Step 5: Secure the anti-torsion sleeve as shown in Figure 5.

3.8 Connecting the Load and Grid cable

The residual current monitoring unit (RCMU) is integrated into the inverter. When the inverter detects the leakage current is higher than 300mA, it can disconnect from the grid quickly. When the external AC switch has a leakage protection function, its rated leakage protection current is required to be $\geq 300\text{mA}$.

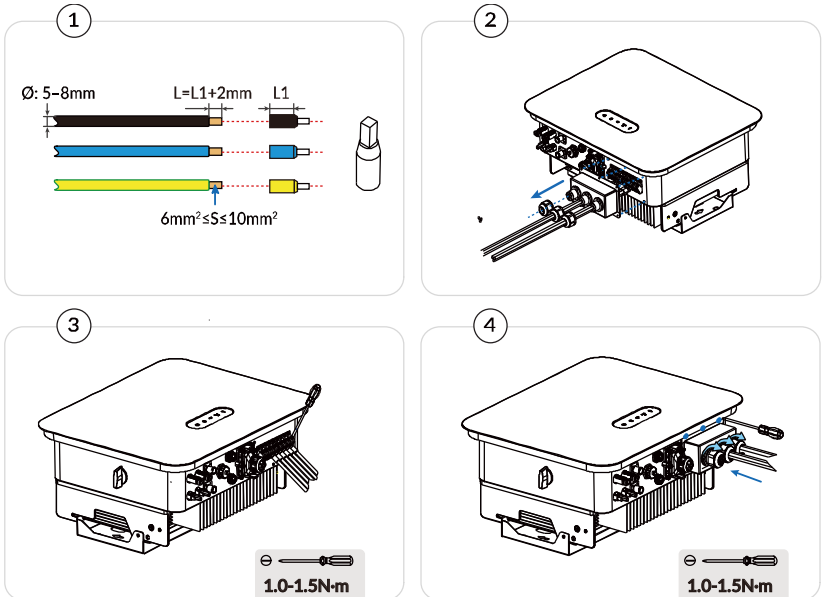

Step 1: Select the appropriate cable type and specification according to Section [3.4 Port cable description](#). And use wire strippers to strip the insulation layer of the specified cable to a suitable length (as shown in Figure 1).

Step 2: Disassemble the AC terminals as shown in Figure 2, and thread the stripped AC cable through the waterproof locking nut.

Step 3: Secure the cable in the AC terminal's locking hole according to the markings, and tighten with an Allen wrench, as shown in Figures 3 and 4.

Step 4: If it is necessary to remove the terminal from the inverter, insert the tool and pull the terminal out by the arrow direction. To disassemble the AC terminal, the same tool should be used.

3.9 Connecting the COM cable

3.9.1 BMS/NTC

Via the BMS/NTC communication port, the NTC of lithium batteries or lead-acid batteries can be connected. It is used for communication between the inverter and the BMS lithium battery and for collecting the temperature of lead-acid batteries. The pins of the BMS/NTC port (RJ45) are defined as follows:

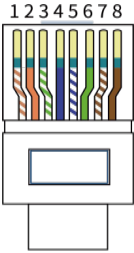
Picture	Pin	Name	Description
	1	Idle	-
	2	Idle	-
	3	NTC-	Lead-acid battery temperature sampling
	4	BAT-CANH	Lithium battery CAN high-level data
	5	BAT-CANL	Lithium battery CAN low-level data
	6	NTC+	Lead-acid battery temperature sampling
	7	BAT-485A	Lithium battery RS485 differential signal +
	8	BAT-485B	Lithium battery RS485 differential signal -

Connecting the BMS/NTC port:

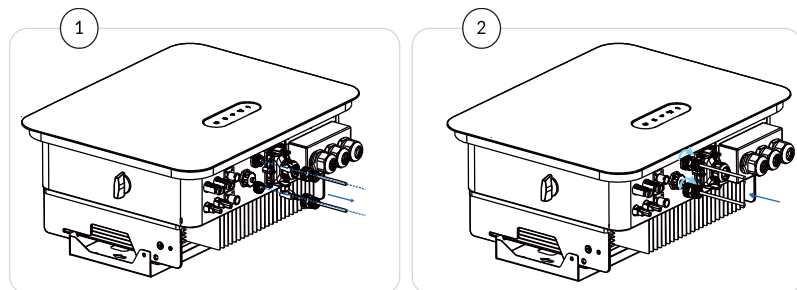

Note: For specific details on the battery usage, please refer to the ELS Series Battery Instructions on the EPEVER official website: <https://www.epever.com/products/>.

- Schematic diagram of external NTC connection for lead-acid batteries

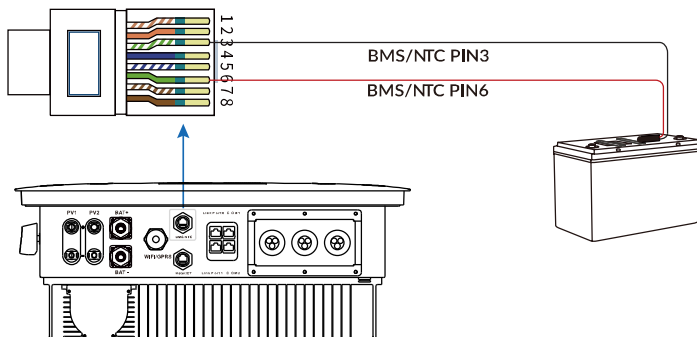

- Schematic diagram of RS485 and CAN communication connections for lithium batteries

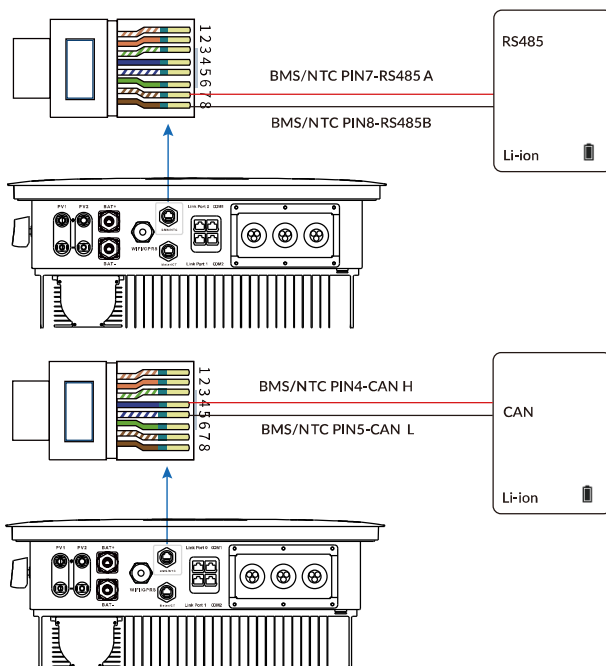

3.9.2 Meter/CT

Differences exist in the use of CT/Meter between single-inverter systems and multi-inverter parallel systems. In a single-inverter system, the CT/Meter is applied to the anti-reverse current and the on-grid load. In a multi-inverter parallel system, the CT/Meter is applied to the load power rating.

The pins of the Meter/CT port (RJ45) are defined as follows:

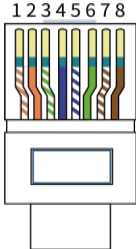
Picture	Pin	Name	Description
	1	CT+	Current transformer output positive pole
	2	CT-	Current transformer output negative pole
	3	Idle	Dry Contact 1 Input
	4	Idle	
	5	Meter-485A	Meter 485 communication
	6	Meter-485B	
	7	Idle	Dry Contact 2 Input
	8	Idle	

- For a single-inverter system without on-grid load, the following three options are used to achieve the anti-reverse current function: CT, Meter, or neither CT nor Meter. See schematic diagrams below for details.

① Without On-Grid Load + Anti-reverse Current + CT

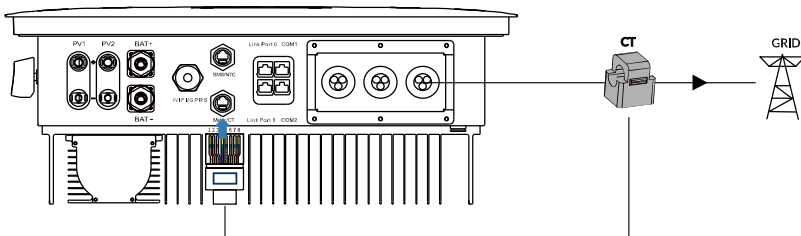

② Without On-Grid Load + Anti-reverse Current + Meter

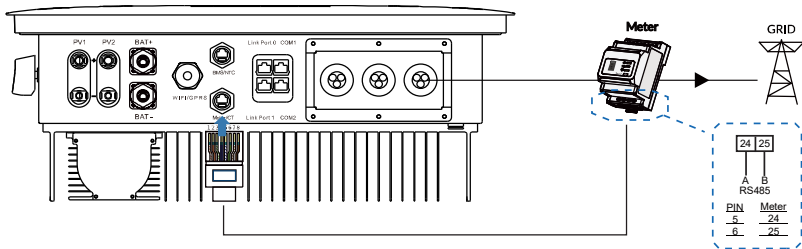

③ Without On-Grid Load + Anti-reverse Current + No CT/ Meter

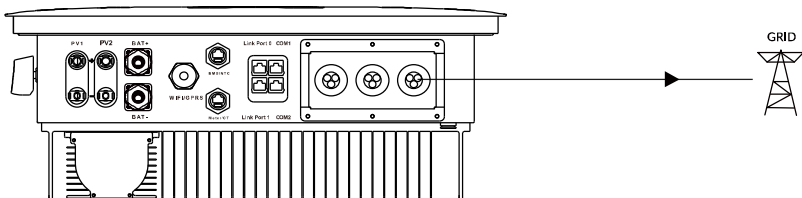

- For a single-inverter system with on-grid load, the following two options are used to achieve the anti-reverse current function: CT and Meter. See schematic diagrams below for details.

① With On-Grid Load + Anti-reverse Current + CT

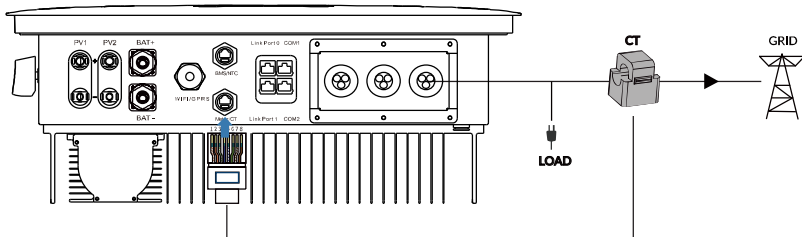

② With On-Grid Load + Anti-reverse Current + Meter

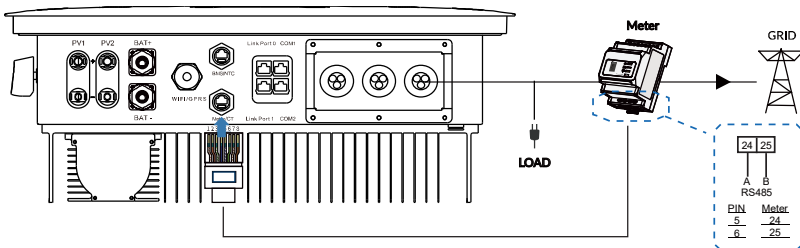

- For a single-inverter system with on-grid load, three options are available when there is no anti-reverse current function: CT, Meter, or neither CT nor Meter. See schematic diagrams below for details.

① With On-Grid Load + No Anti-reverse Current + CT

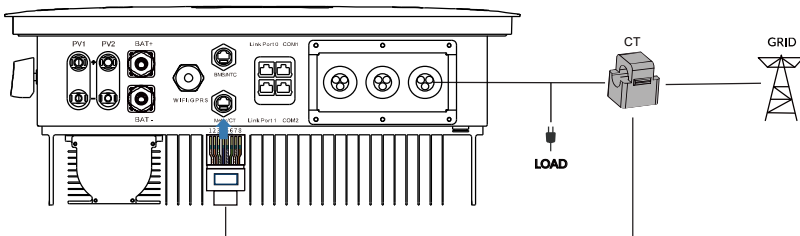

② With On-Grid Load + No Anti-reverse Current + Meter

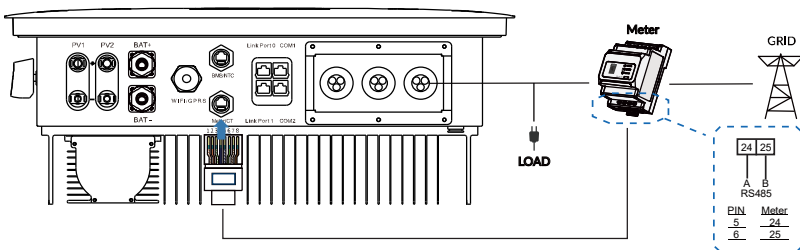

③ Without On-Grid Load + No Anti-reverse Current + No CT/ Meter

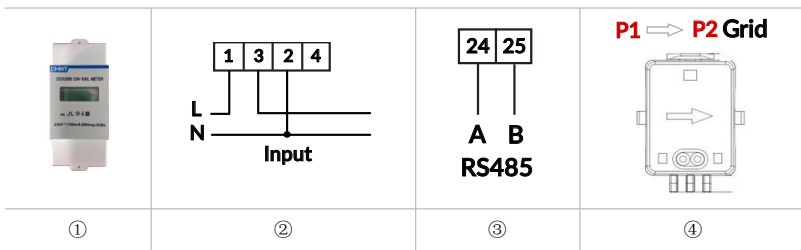
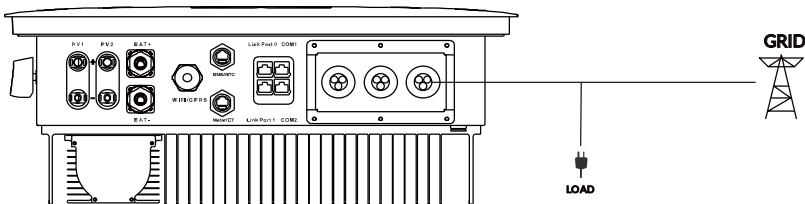

- PIN 5 and PIN 6 of the inverter Meter/CT port are used for meter communication. Meter appearance is shown as Figure ①.
- PIN 5 and PIN 6 of the inverter Meter/CT port correspond to PIN 24 and PIN 25 of the meter module, shown as Figure ③.
- Connection method of meter module is shown as Figure ②. PIN 1/3 are connected to the voltage signal L, and PIN 2 is connected to the voltage signal N.

3.9.3 COM1/COM2

The pins of the COM1 port (RJ45) are defined as follows:

Picture	Pin	Name	Description
	1	GND-S	DRM interface
	2	DRMS 1/5	
	3	DRMS 2/6	
	4	DRMS 3/7	
	5	DRMS 4/8	
	6	DRMS 0	
	7	Monitor-485A	PC software 485 communication
	8	Monitor-485B	

The pins of the COM2 port (RJ45) are defined as follows:

Picture	Pin	Name	Description
	1	Gen-START-Rly	Generator start relay
	2	Gen-START-Rly	
	3	Gen-ON-Rly	Generator back-up relay
	4	Gen-ON-Rly	
	5	RSD-IN	RSD switch input
	6	RSD-IN	
	7	RSD-12V+	12V power output
	8	RSD-12V-	

Connecting the COM port:

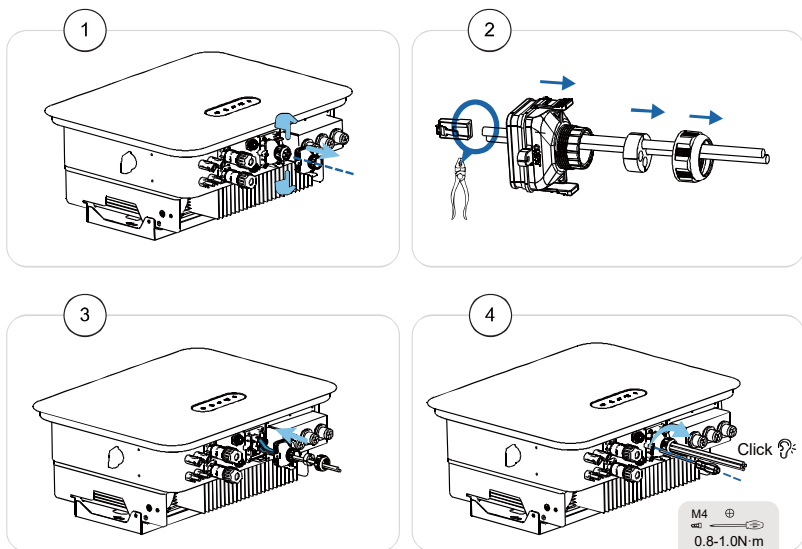

- RS485 (monitoring via cable)

As shown in the figure, connect the RS485+ and RS485- of the inverter to the TX+ and TX- of the RS485 to USB adapter, and then connect the adapter's USB port to the computer.

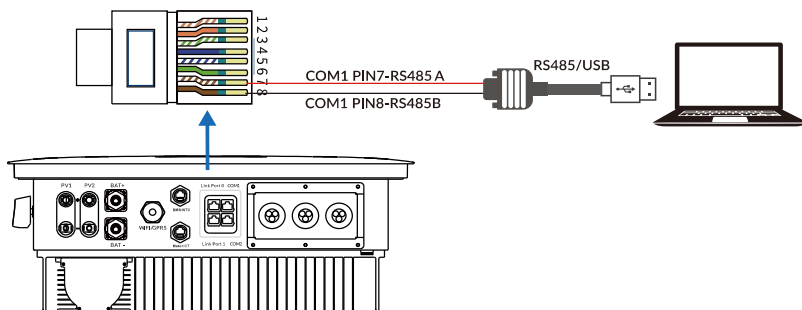

- RS485 (inverter cascade monitoring)

NOTICE

When multiple inverters are connected via RS485 communication cables, different communication addresses must be set to distinguish the inverters.

Multiple inverters are connected in parallel through RS485 communication cables.

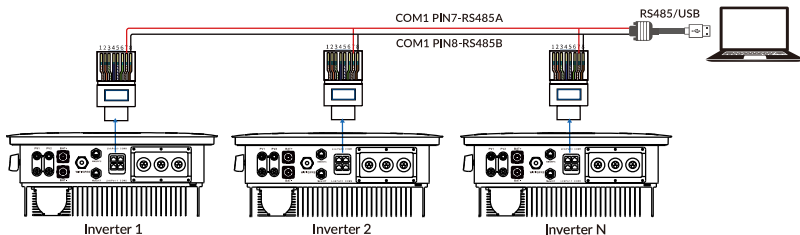

- RSD rapid shutdown and emergency power off

The emergency shutdown pins (PIN5, PIN6) of COM2 port are normally open contacts, which can trigger a rapid shutdown when closed. The RSD will cut off all power, including the inverter internal power, and stop all AC and DC outputs. The internal 12VDC power supply (PIN7, PIN8) of the inverter will disconnect the power supply to the RSD transmitter. After pressing the emergency stop button, the RSD transmitter will cut off all input circuits of the solar panels.

- The emergency power off button (normally open) is connected to the PIN5 and PIN6 of COM2 port.
- The RSD transmitter is connected to PIN7 (+) and PIN8 (-) (12VDC power supply).
- Configured the RSD transmitter in the residential hybrid inverter may cause interference in the user area.

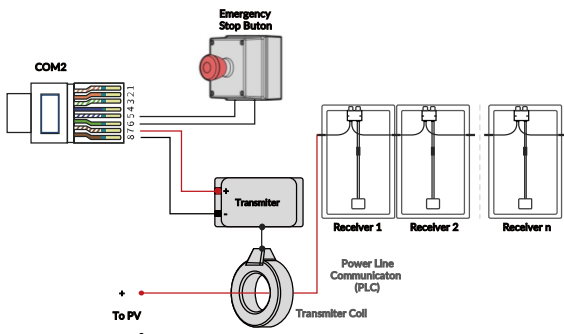

NOTICE

- The rated current of the built-in 12V DC power supply is 100mA (1.2W). Overloading is strictly prohibited.
- If the rated current of the RSD transmitter exceeds 100mA, please contact the manufacturer before installation.

When the rated current of the RSD transmitter exceeds 100mA, an external power converter is needed to power the RSD transmitter. The input of the power converter is connected to the Back-up port of the distribution box. Once the emergency stop button is pressed, all outputs including power to the Back-up port will be shut down. And then, the RSD transmitter will be immediately turned off.

Recommended RSD transmitter model: APsmart Transmitter-PLC 406001;

Recommended PV rapid shutdown (receiver) model: RSD-S-PLC

Note: Please select the PV rapid shutdown switch (receiver) based on the actual PV panel model used.

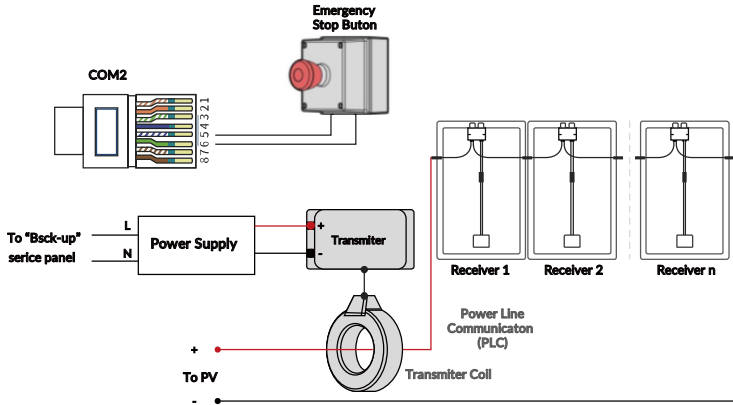

3.9.4 WiFi/GPRS com. port

Connect a USB drive to the WiFi/GPRS com. port for inverter firmware upgrades, or connect a WiFi/GPRS module for inverter remote monitoring. The pins of the WiFi/GPRS com. port (USB-A 3.0) are defined as follows:

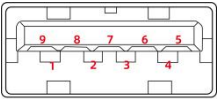
Picture	PIN	USB-A 3.0	Description
	1	+5V	+5V
	2	D-	Data interface
	3	D+	
	4	GND	Power ground
	5	RS485-A	RS485 communication
	6	RS485-B	
	7	Idle	--
	8	Idle	--
	9	Idle	--

Connect the WiFi/GPRS com. port

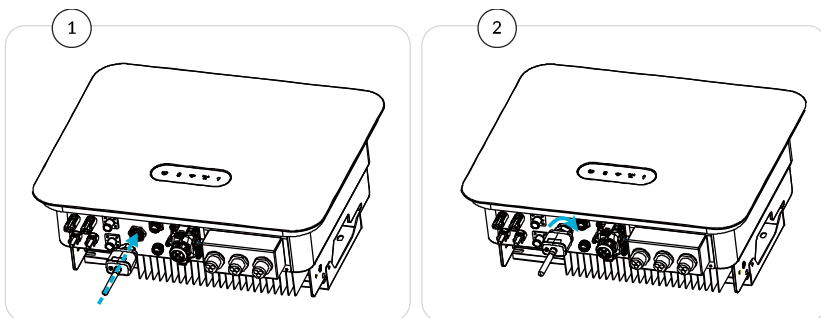

- Connecting a WiFi/GPRS module for single inverter

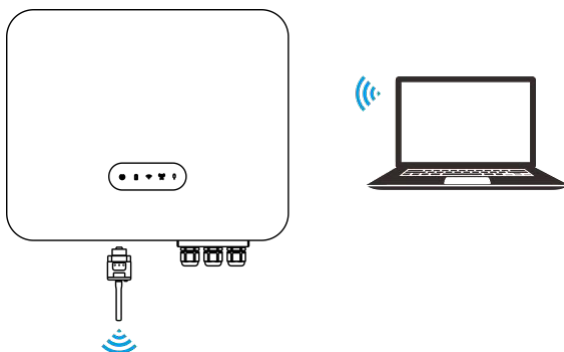

- Connecting WiFi/GPRS modules for multiple inverters

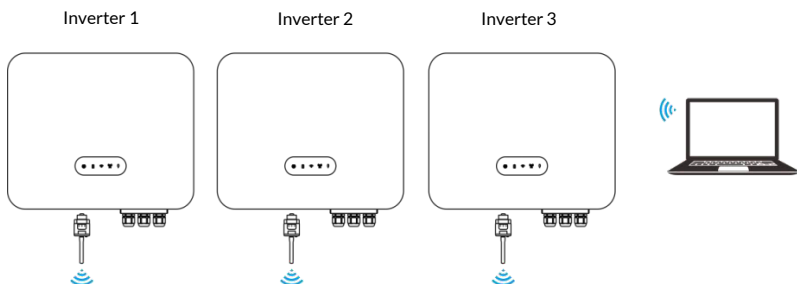

The inverter's operational information (such as power generation, alarms, and operational status) can be uploaded to the server via communication modules like WiFi/GPRS. Users view this information via a WEB interface or an APP, as needed. An account for the WEB or APP is required, and users need to bind the inverter with the serial number of the WiFi/GPRS communication module. The WiFi/GPRS serial number is stuck on both the packaging box and the module itself.

3.9.5 Parallel connection port

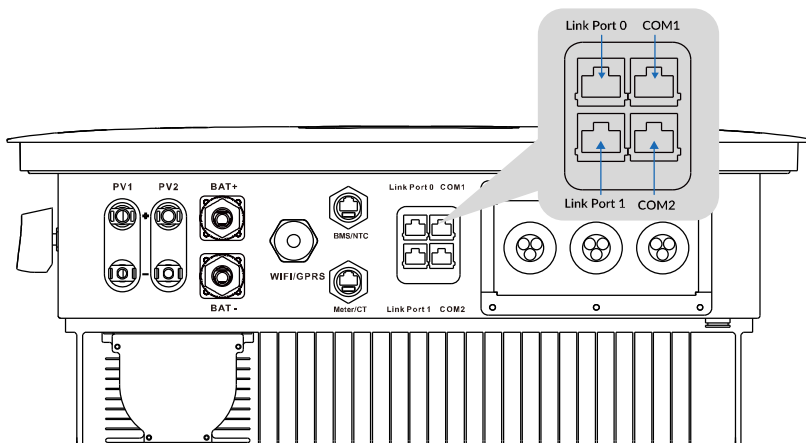

In the parallel system, one of the inverters is set as the master and the others as slaves through APP or monitoring software.

For the scenario where critical load is also connected in parallel under parallel system:

- Connect 8-pin connectors with the Link Port 0 and Link Port 1 on the first and last inverters.
- The cable length and specification from the load devices to the AC LOAD terminal of each inverter should be the same to ensure the same loop impedance, thereby ensuring that the load current shunts to each inverter are nearly equal.
- When the load power is greater than the maximum AC LOAD power of the parallel system, the load needs to be connected to the AC GRID terminal (not the AC LOAD terminal). For example, the maximum AC LOAD power of one inverter is 6KW, and the maximum AC LOAD power of six inverters is 36KW.

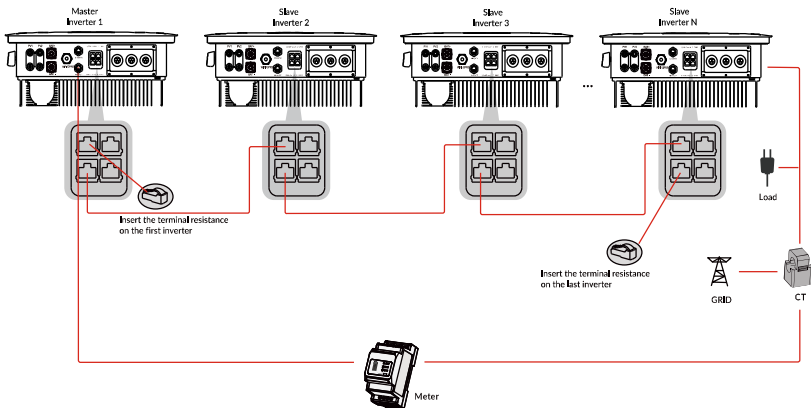

Note: The dedicated parallel operation meter (optional CHINT DDSU666.014 single-phase rail-mounted electricity meter) and the dedicated parallel operation CT (300A) are required. For specific details on the parallel operation, please refer to the “ELS Series Parallel Operation Guide” on the EPEVER official website: <https://www.epever.com/products/>.

3.9.6 AFCI setup

Causes for arc generation:

- Damage to connectors in PV or battery systems.
- Improper cable connection or breakage.
- Aging of connectors and cables.

Methods for detecting arcs:

- The inverter integrates AFCI function and complies with IEC63027.
- When the inverter detects an arc, the user can view the APP to find the arc fault history.
- The inverter will shut down for protection until the AFCI fault is removed. After the AFCI fault is removed, the inverter can automatically reconnect to the grid.
 - Automatic re-connection: If the fault is triggered less than 5 times within 24 hours, the inverter will automatically remove the fault within 5 minutes.
 - Manual re-connection: When the fifth arc fault occurs within 24 hours, the inverter will shut down. Users can remove the faults through the APP, or restart the system after powering off. After the inverter removes the fault, it will reconnect to the grid and operate.

By default, the AFCI function is disabled and can be enabled through the APP.

AFCI operation steps:







Step 1: Open the parameter setting of the APP and find the AFCI module setting.

Step 2: Read the AFCI parameter values.

Step 3: Enable the AFCI module.

4 Indicator



No.	Indicator	Icon	Status	Description
1	Operating		Flashing blue (2s on 2s off)	Standby
			Flashing blue (1s on 1s off)	Self-test
			Solid blue	Normally running
			Flashing red (1s on 1s off)	Recoverable faults
			Solid red	Non-recoverable faults
2	Battery		Solid ON	Battery online
			OFF	Battery dropout
3	IoT		Solid ON	Data sending in Software/IoT
			OFF	No data sending in Software/IoT
4	Grid		Solid ON	Normal grid
			OFF	Abnormal grid
5	Load		Solid ON	Normal AC output
			OFF	Abnormal AC output
6	Upgrade		Pink	Upgrade successful
			Flashing red/Solid red	Upgrade failed
			Flashing	Upgrading

5 Commissioning

5.1 Check before powering on

Please check the following items again before powering on.

- The inverter is securely fixed to the mounting plate.
- The PV cables are securely connected, correctly polarized, and the PV input is within the acceptable voltage range of the inverter.
- The Battery cables are securely connected, correctly polarized, and the battery input is within the acceptable voltage range of the inverter.
- The DC switch is correctly connected between the battery and the inverter, and the DC switch is in the off state.
- The grid and load cables are securely and correctly connected.
- The AC circuit breaker is correctly connected between the inverter grid port and the power grid, and the circuit breaker is disconnected.
- The AC circuit breaker is correctly connected between the inverter load port and the critical load, and the circuit breaker is disconnected.
- For lithium batteries, ensure that the communication cables are properly connected.
- For lead-acid batteries, ensure that the NTC cables are properly connected.

5.2 Initial power on (Important)

Please follow the steps below to turn on the inverter.

Step 1: Ensure that no power generation occurs on the phase connected to the inverter.

Step 2: Turn on the DC switch.

Step 3: Turn on the battery (i.e., turn on the DC switch between the battery and the inverter).

Step 4: Connect the AC circuit breaker between the inverter grid port and the power grid.

Step 5: Connect the AC circuit breaker between the inverter load port and the critical load.

Step 6: Complete the inverter power-on.

Step 7: Set inverter parameters via the APP to ensure it is working normally. The following parameters must be set correctly:

- (1) Select **Safety Code**.
- (2) Select **PV Input Mode** ("Independent" mode by default).
- (3) Select **Operation Mode** ("Self Consumption" by default).
- (4) Select **Battery Model** on the Battery Configuration interface.

- (5) Select **Remote Switching** as **ON** to power on the inverters remotely for grid connecting.

5.3 APP settings

Add the WiFi adapter and the connected device to the cloud server by website (<https://www.valueclouds.com>) or APP. Then you will be able to monitor the device and set parameters by PC or APP.

Note: For the details of APP setting, please refer to the “ELS Series APP Instructions Manual” on the EPEVER official website: <https://www.epever.com/products/>.

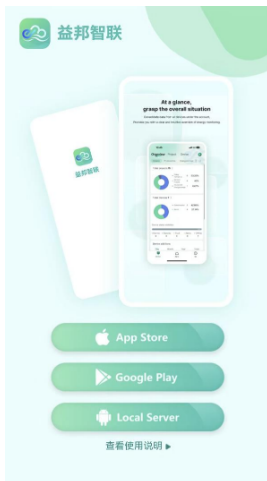

6 Troubleshooting and Maintenance

6.1 Inverter powering off

Step 1: Disconnect the inverter grid AC breaker.

Step 2: Disconnect the inverter back-up AC breaker.

Step 3: Disconnect the DC breaker between the inverter and the battery.

Step 4: Turn off the DC switch of the inverter.

6.2 Inverter dismantling

Step 1: Disconnect all electrical connections of the inverter, including: DC lines, AC lines, communication lines, communication modules, and protective ground lines.

Step 2: Remove the inverter from the mounting plate.

Step 3: Dismantle the mounting plate.

Step 4: Properly store the inverter. If the inverter is to be reused in the future, ensure that storage conditions meet the requirements.

6.3 Troubleshooting

Verify the fault cause by checking the status of the inverter indicators (refer to Chapter 4 [Indicator](#) for fault cause identification); or access the alarm information within the APP. On the APP's main screen, select "Site > Device List", click on a device to access its relevant information page, and then click "Alarm Messages" to view the fault details. Then, refer to the error information and solutions provided in the table below to try to resolve the fault.

If the inverter LED or APP does not display any error information, please refer to the following to see if the current installation status meets the requirements for the inverter to work properly. If not, make the right adjustments and then check if the fault has been solved.

- Check whether the inverter is installed in a clean, dry and well-ventilated location. Dampness and poor ventilation may cause adverse effects on the operation of the device.
- Check whether the DC switch is in the ON position. If it is in the OFF position, it may affect the normal start-up and operation of the device.
- Check whether the cross-section and length of the cable meet the requirements. Inappropriate cable specifications may lead to abnormal current transmission and thus trigger faults.
- Check whether the input, output connections and wiring are in good condition to ensure that there are no loose connections, short circuits, etc., and to guarantee stable and reliable circuit connections.
- For specific installations by users, confirm whether the configuration settings are correct.

Incorrect configurations may prevent the inverter from operating as expected.

- Check whether the display panel and communication cable are correctly connected and undamaged. If the connection is improper or the cable is damaged, it may result in the inability to display or transmit information normally.

If you still need assistance after above operations, please contact the after-sales service center.

The error information and solutions are as follows:

ID	Failure	Solution
1	GridOVP (Grid Over Voltage)	If it occurs occasionally, it may be occasional abnormalities in the power grid. After the power grid returns to normal, the inverter will automatically resume working.
2	GridUVP (Grid Under Voltage)	If it occurs frequently, check whether the grid voltage/frequency is within the specified range of the inverter.
3	VGridLineFault (Grid Line Voltage Error)	
4	GridOFP (Grid Over Frequency)	
5	GridUFP (Grid Under Frequency)	<ul style="list-style-type: none"> - If the grid voltage/frequency is within the specified range of the inverter, check the inverter's AC circuit breaker and AC wiring. - If the grid voltage/frequency is not within specified range and the AC wiring is correct, but there are still multiple alarms, contact technical support to adjust the grid over/under voltage and over/under frequency protection values.
6	OVRT (Over Voltage Ride Through Error)	This is an internal fault of the inverter. Please turn off the inverter, and then turn it back on after waiting for 5 minutes to check if the fault disappears. If the issue remains unresolved, please contact our technical support.
7	LVRT (Low Voltage Ride Through Error)	
8	IslandFault (Island Fault)	
17	GEN_OVP (Generator Over Voltage)	Check whether the generator is working normally.
18	GEN_UVP (Generator Under Voltage)	

19	GEN_OFP (Generator Over Frequency)	
20	GEN_UFP (Generator Under Frequency)	
21	GEN_OverLoad (Generator Overload)	
22	GEN_RefluxOverLoad (Generator Anti-reflux Overload)	
23	Overload1	
24	Overload2	
25	Overload3	
26	InvVoltFault (Inverter Voltage Fault)	
27	SwInvInstantOVP (Inverter Peak Over Voltage)	
28	SwAcRmsOCP(Inverter RMS Over Current)	<p>This is an internal fault of the inverter. Please turn off the inverter, and then turn it back on after waiting for 5 minutes to check if the fault disappears. If the issue remains unresolved, please contact our technical support.</p>
29	SwAcOCPInstant (Inverter Peak Over Current)	
30	HwAcOCP (Inverter Hardware Over Current)	
31	IacUnbalance (Inverter Current Unbalance)	
32	DciOCP (Inverter DC Component Over Current)	
33	HwADFaultVAC (AC Side Voltage Reference Error)	
34	HwADFaultIAC (AC Side Current Reference Error)	
35	HwADFaultIdc (DC Side Current Reference Error)	<p>This is an internal fault of the inverter. Please turn off the inverter, and then turn it back on after waiting for 5 minutes to check if the fault disappears. If the issue remains unresolved, please contact our technical support.</p>
36	HwADFaultDCV (Inverter Voltage DC Component Reference Error)	
37	HwADFaultDCI (Inverter Current DC Component Reference Error)	

38	HwADFaultVGrid_Slave (Slave Chip Grid Voltage Reference Error)	
39	GFCIDeviceFault_Slave (Slave Chip Leakage Current Sampling Error)	
40	ConsistentFault_Vgrid (Grid Voltage Inconsistency)	
41	ConsistentFault_DC1 (Inverter Current DC Component Inconsistency)	
42	ConsistentFault_GFC1 (Leakage Current Inconsistency)	
43	GFCIDeviceFault (Leakage Current Sampling Error)	
44	GFC1 (Leakage Current Fault)	
45	CTDisconnect (CT Current Error)	Check whether the CT connection is correct.
46	SwGridRmsOCP (Grid RMS Over Current)	
47	RefluxOverLoad (Anti-backfeeding Overload)	
48	RelayFail (Bypass Relay Error)	
49	SwBusOVP (Bus Average Over Voltage)	
50	SwBusInstantOVP (Bus Peak Over Voltage)	
51	HwBusOVP (Bus Hardware Over Voltage)	
52	BusUVP (Bus Undervoltage During Grid Connection)	
53	BusZVP (Bus Low Voltage)	
59	LLCBusOVP (LLC Bus Over Voltage)	
60	HwLLCBusOVP (LLC Bus Hardware Over Voltage)	
		This is an internal fault of the inverter. Please turn off the inverter, and then turn it back on after waiting for 5 minutes to check if the fault disappears. If the issue remains unresolved, please contact our technical support.

66	BatLowVoltageShut (Battery Low Voltage Shutdown)	Check whether the battery voltage is too low.
67	SwBatOCP (Battery Over Current)	Check whether the inverter is working overload.
68	HwBatOCP (Battery Hardware Over Current)	This is an internal fault of the inverter. Please turn off the inverter, and then turn it back on after waiting for 5 minutes to check if the fault disappears. If the issue remains unresolved, please contact our technical support.
69	SwBuckBoostOCP (BuckBoost Peak Over Current)	
70	HwBuckBoostOCP (BuckBoost Hardware Over Current)	
73	PvOVP (PV Over Voltage)	
74	SwPvOCPInstant (PV Peak Over Current)	
75	HwPVOC (PV Hardware Over Current)	
76	IpvUnbalance (PV Current Unbalance)	
77	PVConfigError (PV Mode Settings Error)	Check the setting of the PV input mode (parallel/single mode). Modify the settings if it is not corresponding to the actual PV input method.
81	IsoFault (Insulation Resistance)	Check the insulation resistance between the PV array and ground (earth). If a short circuit occurs, repair the fault in time.
82	PEConnectFault (Grounding Error)	Check the grounding of the PE line for the AC output.
83	AFCIFault (AFCI Fault)	Check the PV input wiring for any loose connections or arcing.
84	AFCIDeviceFault (AFCI Module Fault)	This is an internal fault of the inverter. Please turn off the inverter, and then turn it back on after waiting for 5 minutes to check if the fault disappears.
89	SpiCommFault_DC (SPI Communication Error (DC))	
90	SpiCommFault (Master-Slave SPI Communication Error)	If the issue remains unresolved, please contact our technical support.

91	SChip_Fault (Slave Chip Error)	
92	MChip_Fault (Master Chip Error)	
93	SciCommLose (SCI Communication Error)	
94	MeterCommLose (Electric Meter Communication Fault)	Check whether the communication cable of the electric meter is properly connected.
95	AFCICommFault (AFCI Communication Fault)	This is an internal fault of the inverter. Please turn off the inverter, and then turn it back on after waiting for 5 minutes to check if the fault disappears. If the issue remains unresolved, please contact our technical support.
96	ParallelFault (Parallel Error)	Check whether the parallel connection cable is in good contact.
97	FanFault (Fan Fault)	Check whether the fan 1 of the inverter is working normally.
98	TempFault_Env1 (Ambient Temperature Over Temperature 1)	Ensure the inverter is installed in a cool, well-ventilated area (do not install the inverter in direct sunlight).
99	TempFault_Env2 (Ambient Temperature Over Temperature 2)	
100	TempFault_Inv1 (Module 1 Over Temperature)	
101	TempFault_Inv2 (Module 2 Over Temperature)	
102	TempFault_Inv3 (Module 3 Over Temperature)	
105	TempFault_Bat (Battery Over Temperature)	
106	TempFault_HeatSink1 (Heat Sink 1 Over Temperature)	
113	VoltDerating (Voltage Derating)	Ensure the grid voltage and frequency

114	VoltLoading (Voltage Loading)	are within the specified range of the inverter.
115	FreqDerating (Frequency Derating)	
116	FreqLoading (Frequency Loading)	
117	OverTempDerating (Over Temperature Derating)	Ensure the inverter is installed in a cool, well-ventilated area (do not install the inverter in direct sunlight).
118	BatLowVoltageAlarm (Battery Low Voltage Alarm)	Check whether the battery voltage is too low.
119	ReversalConnection (PV Input Reverse Connection Alarm)	Check whether the positive and negative poles of the PV input cable are reversed.
129	unrecoverPvConfigError (PV Mode Settings Permanent Fault)	<p>This is an internal fault of the inverter. Please turn off the inverter, and then turn it back on after waiting for 5 minutes to check if the fault disappears.</p> <p>If the issue remains unresolved, please contact our technical support.</p>
130	unrecoverPVOCPInstant (PV Over Current Permanent Fault)	
131	unrecoverHwPVOCP (Hardware PV Over Current Permanent Fault)	
132	unrecoverRelayFail (Grid Relay Permanent Fault)	
133	unrecoverVbusUnbalance (Bus Unbalance Permanent Fault)	
134	unrecoverOverLoad (Overload Permanent Fault)	
137	unrecoverHwAcOCP (Hardware Inverter Over Current Permanent Fault)	
138	unrecoverBusOVP (Bus Over Voltage Permanent Fault)	
139	unrecoverHwBusOVP (Bus Hardware Over Voltage Permanent Fault)	
140	unrecoverIpvUnbalance (PV Current Unbalance Permanent Fault)	
141	unrecoverEPSBatOCP (EPS Battery Over Current Permanent Fault)	
142	unrecoverAcOCPInstant (Inverter Peak	

	Over Current Permanent Fault)	
143	unrecoverlacUnbalance (AC Current Unbalance Permanent Fault)	
144	unrecoverAFCIFault (AFCI Permanent Fault)	
145	BMSOVP (BMS Over Voltage Alarm)	This is an internal fault of the lithium battery. Please turn off the inverter and lithium battery, and then turn them back on after waiting for 5 minutes to check if the fault disappears. If the issue remains unresolved, please contact our technical support.
146	BMSUVP (BMS Under Voltage Alarm)	
147	BMSOTP (BMS High Temperature Alarm)	
148	BMSUTP (BMS Low Temperature Alarm)	
149	BMSOCP (BMS Charging/Discharging Over Current)	
150	BMSShort (BMS Short Circuit Alarm)	
161	ARM update Fail (ARM Update Failed)	If the upgrade fails, make multiple times of plugging and unplugging or perform a re-upgrade after powering on. If the issue remains unresolved, please contact our technical support.
162	DSP-M update Fail (Master DSP Update Failed)	
163	DSP-S update Fail (Slave DSP Update Failed)	
164	BMSLink update Fail (BMSLink Update Failed)	
171	Drms0Shutdown (Drms0 Shutdown)	The inverter is shut down via Drms0.
177	USBFault (USB Fault)	Check the inverter USB port.
178	WifiFault (WiFi Fault)	Check the WiFi connection of the inverter.
179	BluetoothFault (Bluetooth Fault)	Check the Bluetooth connection of the inverter.
180	RTCFault (RTC Fault)	This is an internal fault of the inverter. Please turn off the inverter, and then turn it back on after waiting for 5 minutes to check if the fault disappears. If the issue remains unresolved, please contact our technical support.
181	EEPROMFault (EEPROM Error)	
182	FlashFault (FLASH Error)	
184	SafetyVerFault (Safety Version Error)	

185	SCIlose(DC) (SCI Communication Error (DC))	
186	SCIlose(AC) (SCI Communication Error (AC))	
189	BMSCommFault (Battery Communication Fault)	Ensure that the batteries you use are compatible with the inverter. CAN communication is recommended. Check for any faults in the communication cables or ports between the battery and inverter.
190	RsdFault (RSD Fault)	Check whether fast shutdown occurs.

6.4 Routine maintenance

Inverters generally require no maintenance or calibration, but it is important to ensure that the heat sinks are not covered by dust, dirt, or other debris.

- **Clean inverter**

Please clean the inverter using an electric compressed air blower, a dry soft cloth, or a soft-bristled brush. Do not use water, corrosive chemicals, cleaning agents, or strong detergents to clean the inverter.

- **Clean heat sink**

To ensure the normal function and long-term use of the inverter, it is crucial to maintain sufficient airflow space around the heat sink. No obstructions to airflow, such as dust or snow, should be present around the heat sink and must be removed. Clean the heat sink using compressed air, a soft cloth, or a soft brush. Do not use water, corrosive chemicals, detergents, or strong cleaning agents to clean the heat sink.

6.5 Inverter disposal

When the inverter can no longer be used and needs to be discarded, please dispose of the inverter in accordance with the electrical waste disposal requirements specified by the current country/region. The inverter should not be treated as household waste.

7 Technical Specifications

Model	ELS3K	ELS3K6	ELS4K	ELS4K6	ELS5K	ELS6K
Battery Parameters						
Battery Type	Lithium battery/Lead-acid battery					
Rated Voltage (V)	48					
Voltage Range (V)	42-63					
Charging Rule	3-stage charging or BMS command					
Maximum Charging and Discharge Current (A)	75	80	85	100	110	120
PV Input Parameters						
Maximum Input Power (W)	4,500	5,400	6,000	6,900	7,500	9,000
Maximum Input Voltage (V) ⁽¹⁾	580					
MPPT Voltage Range (V)	100-550					
Start-up Voltage (V)	100					
Rated Input Voltage (V)	360					
Maximum Input Current (A)	16					
Maximum Short Circuit Current (A)	19.2					
MPPT Input Channels	1		2			
Number of Strings per MPPT	1					
AC Output Parameters (On-grid)						
Maximum Output Power (VA)	3,300	4,050	4,400	5,060	5,500	6,600
Rated Output Apparent Power (VA)	3,000	3,680	4,000	4,600	5,000	6,000
Rated Output Voltage (V)	230					
Rated Output Frequency (Hz)	50					
Maximum Output Current (A)	14.3	17.6	19.1	22	23.9	28.6

Maximum Input Current (A)	28.6	35.2	38.2	43	47.8	55
Load Power Factor	0.99 (Adjustable from ± 0.8 leading to 0.8 lagging)					
THDi (Total Harmonic Current Distortion) @ Rated Output Power	< 3%					
AC Output Parameters (Off-grid)						
Rated Output Power (VA)	3,000	3,680	4,000	4,600	5,000	6,000
Peak Power (VA), Time (s)	1.5* Rated Power, 60s					
Overload Power (VA), Time (s)	1.25* Rated Power, 300s					
Switch Time (ms)	10					
Rated Output Current (A)	13.1	16	17.4	20	21.7	26.1
Rated Output Voltage (V)	230					
Rated Output Frequency (Hz)	50/60Hz ($\pm 0.5\%$)					
THDu (Total Harmonic Voltage Distortion) @Linear loads	< 3%					
Efficiency						
Maximum Efficiency	97.6%		97.8%		98%	
European Efficiency	97.2%		97.3%		97.5%	
Maximum Discharge Efficiency	94.6%					
MPPT Efficiency	99.9%					
General Parameters						
Protections	PV reverse polarity/insulation resistance/ overcurrent/overvoltage/over temperature/ anti-islanding/leakage current protection					
DC Switch	Included					
AFCI	Optional					

SPD Protections	DC Type II/AC Type III
RSD Rapid Shutdown	Optional
Generator Auto Start-up	2 Wire Start
Working Temperature Range	-30°C to +60°C (> 45°C derating)
Relative Humidity	0% to 95% (N.C)
Maximum Working Altitude	4,000m (> 2,000m derating)
Cooling Method	Natural
User Interface	LED & APP
Communication with BMS	RS485/CAN
Communication with Meter	RS485
Monitoring Method	WiFi/Bluetooth (External)
Net Weight (kg)	28.1
Dimension W × H × D (mm)	558.1 × 455.1 × 222.5
Noise Emission (dB)	< 25
Topology	High-Frequency Isolation (Battery)
Standby Losses (W)	< 10
Ingress Protection Rating	IP65
Mounting Method	Wall Mounted

(1) The maximum input voltage refers to the voltage at an ambient temperature of -30°C.

Any changes without prior notice! Version number: V1.1



HUIZHOU EPEVER TECHNOLOGY CO., LTD.

+86 - 752-3889706

info@epeer.com

www.epeer.com