

VALVE REGULATED LEAD-ACID RECHARGEABLE BATTERY

FL1250L (12V5Ah/20hr)

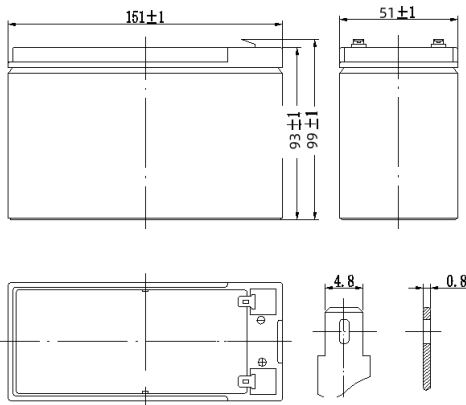
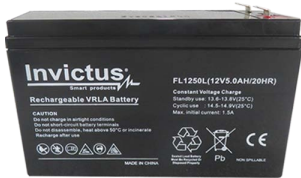

FL Series

FL Series Valve Regulated Lead Acid batteries are designed with AGM (Absorbent Glass Mat) technology, high performance plates and electrolyte to gain extra power output for common power backup system applications widely used in the field of UPS, Emergency Lighting System.

Application

- Alarm System
- Cable Television
- Power tools
- Emergency Power System
- Security System
- Medical Equipment
- UPS
- Communication Equipment
- Control Equipment
- Toys

General Features

- Sealed and maintenance free operation.
- Non-Spillable construction design.
- ABS containers and covers(UL94HB, UL94V-0) optional.
- Safety valve installation for explosion proof .
- High quality and high reliability.
- Exceptional deep discharge recovery performance.
- Low self discharge characteristic.
- Flexibility design for multiple install positions.

CONSTRUCTION

Component	Positive plate	Negative plate	Container	Cover	Safety valve	Terminal	Separator	Electrolyte
Raw material	Lead dioxide	Lead	ABS	ABS	Rubber	Copper	Fiberglass	Sulfuric acid

TECHNOLOGY PARAMETER

Battery model	FL1250L			
Designed Floating Life	5 Years			
Capacity (25°C)	20HR(0.25A, 10.5V)	10HR(0.497A, 10.5V)	5HR(0.91A, 10.5V)	1HR(3.62A, 9.60V)
	5.0Ah	4.97Ah	4.55Ah	3.62Ah
Dimensions	Length	Width	Height	Total Height
	151±1mm	51±1mm	93±1mm	99±1mm
Approx. weight (±3%)	1.75 Kg (3.86 lbs)			
Internal resistance	Full charged at 25°C: Approx. 34mOhms			
Self discharge	3% of capacity declined per month at 25°C (average)			
Capacity Affected by Temp.(20HR)	40 °C	25 °C	0 °C	-15 °C
	102%	100%	85%	65%
Charge Voltage (25°C)	Cycle use		Float use	
	14.5-14.9V(-30mV/°C), max. Current: 1.5A		13.6-13.8V(-20mV/°C)	

VALVE REGULATED LEAD-ACID RECHARGEABLE BATTERY

FL1250L (12V5Ah/20hr)

Constant current discharge ratings-amperes at 25°C

End Point Volts/Cell	5min	10min	15min	30min	1h	3h	5h	10h	20h
1.60V	19.9	14.0	10.6	5.98	3.62	1.52	0.99	0.523	0.272
1.65V	18.9	13.3	10.1	5.75	3.55	1.47	0.96	0.514	0.267
1.70V	17.8	12.6	9.59	5.50	3.46	1.42	0.94	0.504	0.261
1.75V	16.7	11.8	9.07	5.22	3.31	1.36	0.91	0.497	0.250
1.80V	15.6	11.2	8.56	4.96	3.15	1.30	0.88	0.487	0.246

Constant power discharge ratings-watts at 25°C

End Point Volts/Cell	5min	10min	15min	30min	1h	3h	5h	10h	20h
1.60V	36.9	25.8	19.8	11.2	6.80	2.86	1.88	1.00	0.52
1.65V	34.9	24.5	18.7	10.7	6.63	2.76	1.82	0.98	0.51
1.70V	32.6	23.0	17.7	10.2	6.43	2.65	1.76	0.95	0.50
1.75V	30.4	21.6	16.6	9.61	6.13	2.52	1.70	0.93	0.47
1.80V	28.1	20.2	15.5	9.03	5.77	2.38	1.63	0.91	0.46

