

SEBANG GLOBAL BATTERY

| Since 1952

Battery For Better Life

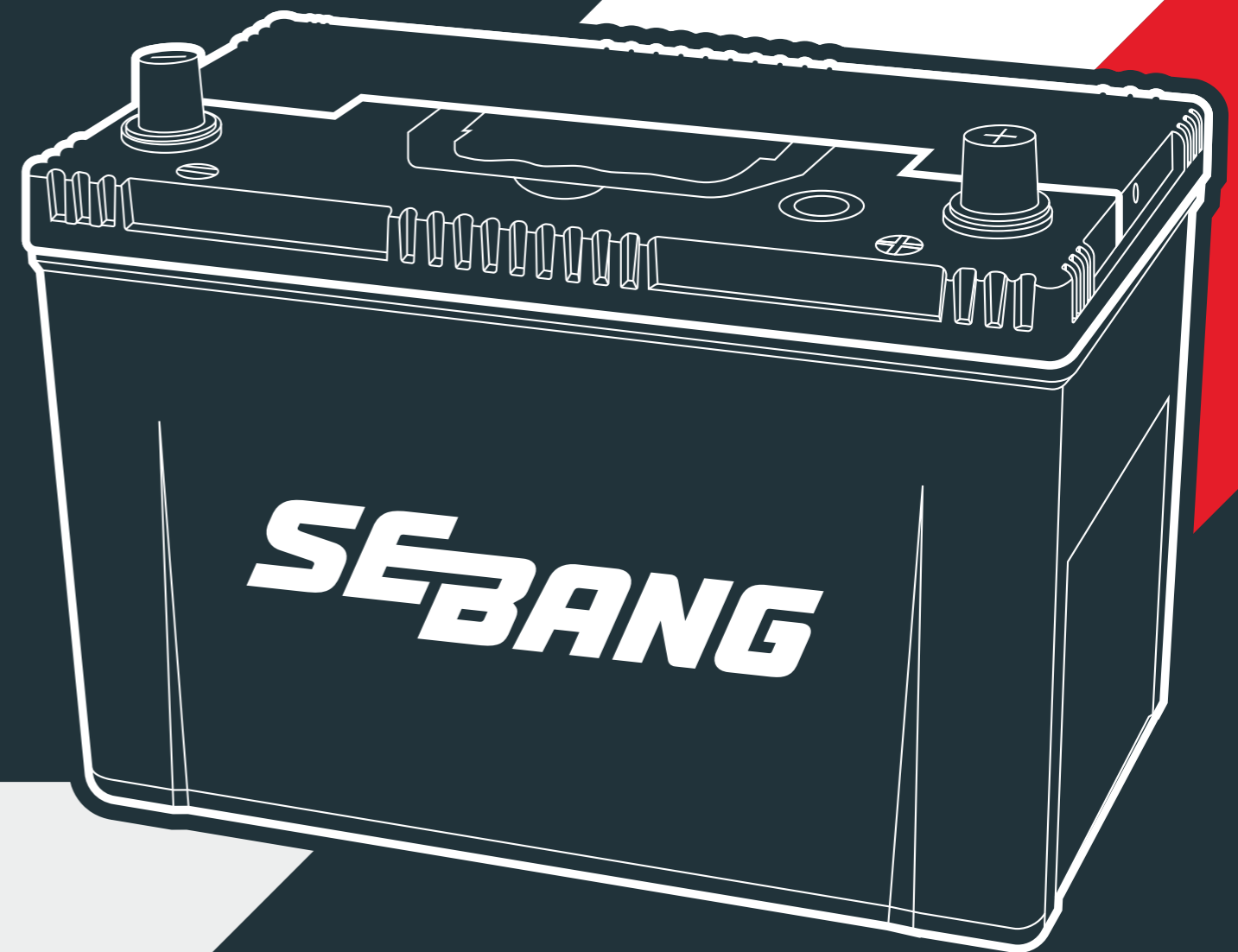

SEBANG

SEBANG GLOBAL BATTERY CO., LTD

www.sebangbattery.com

Distributed by



Al-Muqarram Auto Parts L.L.C

P.O.Box: 60235, Dubai, UAE, Tel: +971 4 2241423, Fax: +971 4 2241450

✉ info@a-map.net 🌐 www.a-map.net 📘 [/amapgroupofficial](https://www.facebook.com/amapgroupofficial) 📺 [/company/a-mapgroup](https://www.linkedin.com/company/a-mapgroup)

BATTERY FOR BETTER LIFE

| Automotive

| Commercial

| Marine & RV

| Lawn & Garden

| Golf Cart

CONTENTS

CHAPTER 01

COMPANY INTRODUCTION

SEBANG GLOBAL BATTERY OVERVIEW	02
SEBANG GLOBAL BATTERY BRANCHES	04

CHAPTER 02

TECHNOLOGIES

SMF	08
AGM & EFB	14
PRODUCT LINE-UP & BRAND AD	20

CHAPTER 03

PRODUCT RANGES

JIS	24
DIN	26
BCI	28
AGM	30
EFB	31
GOLF CART	32

CHAPTER 04

REFERENCES

TECHNICAL INFORMATION	36
BATTERY PRINCIPLES AND FEATURES	38
PROCEDURE OF REPLACEMENT	39
PRECAUTIONS	39

CHAPTER 01.

COMPANY INTRODUCTION

- SEBANG GLOBAL BATTERY OVERVIEW
- SEBANG GLOBAL BATTERY BRANCHES

Battery For Better Life

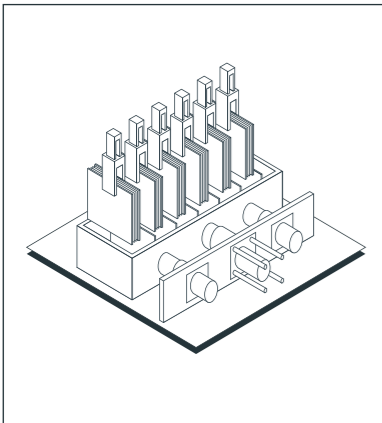

Sebang Global Battery is a specialized manufacturer of automotive and industrial batteries that exports products to more than 130 countries worldwide. Since its establishment in 1952, Sebang Global Battery has achieved stable growth through management innovation and technological development, and currently holds approximately 43% of the domestic lead-acid battery market share, making it the top player. Sebang Global Battery has a variety of product lines that suit different usage environments and continues to invest in research and development to lead the battery market. Its high-quality products have passed international standards (KS, ISO/TS16949), and it boasts the largest domestic production capacity through expanding production lines at factories and establishing new ones.

SEBANG

SEBANG GLOBAL BATTERY

In addition, Sebang Global Battery supplies products to global automotive companies, and actively invests in independent technology research and development since expanding its R&D center in 2016. Its subsidiary, Sebang Lithium Battery, also has the world's highest level of product portfolio by producing auxiliary power devices for vehicles, battery modules and packs for electric vehicle drives using lithium batteries. Sebang Global Battery secures the competitiveness of future growth businesses based on new technologies and strict quality management. In the future, Sebang Global Battery aims to expand its business scope and become a global battery company by leveraging its accumulated technological capabilities and sales networks established in major regions worldwide to expand not only in the existing product market but also in the next-generation battery market.

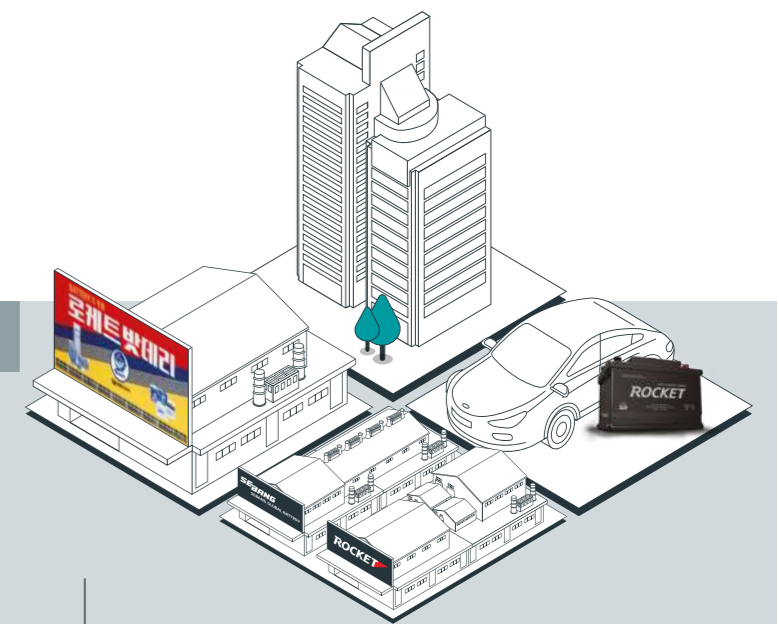

PRODUCTION CAPACITY

OPERATION RATE

GWANGJU_19M / yr

CHANGWON_6M / yr

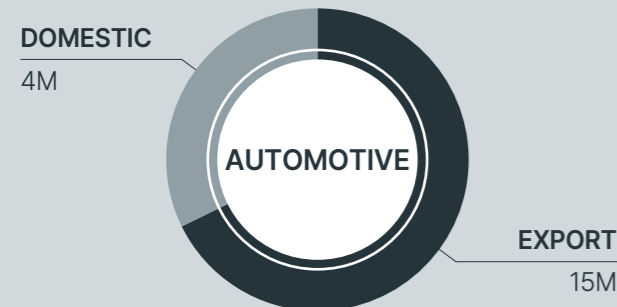

GWANGJU PLANT

- Production Capacity : 19Mpcs / yr
- Highly Automated Production Line
- Flooded Battery & EFB (Auto/Commercial/Marine & RV/Lawn & Garden)

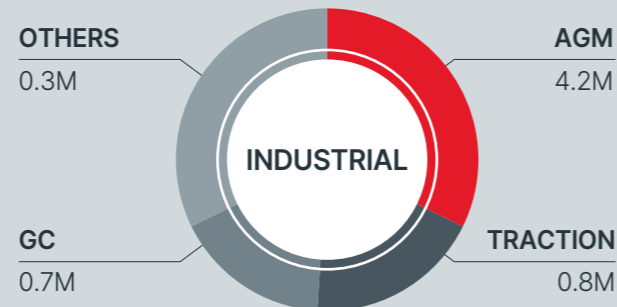

CHANGWON PLANT

- Production Capacity : 6 Mpcs / yr
- AGM Technology
- Only Manufacturer for Industrial Battery in Korea (Back-up Power Solution, Telecommunications, Golf Cart, Folk Lift, etc.)

SEBANG GLOBAL BATTERY HISTORY

- 1952.09** Starting the first step as the Naval Institute of Technology
- 1966.02** The first battery company in Korea
- 1978.09** Beginning and development of Sebang Global Battery
- 1987.11** Becoming an enterprise
- 1997.10** Growing company
- 2006.03** Golf Car Battery LONGEST launched
- 2010.09** Premium AGM Battery launched
- 2015.06** Opened Europe Overseas Office in Germany
- 2021.08** Opened North America Office in Denver, CO

SEBANG GLOBAL BATTERY BRANCHES

“ REPRESENTING KOREAN BATTERY INDUSTRY

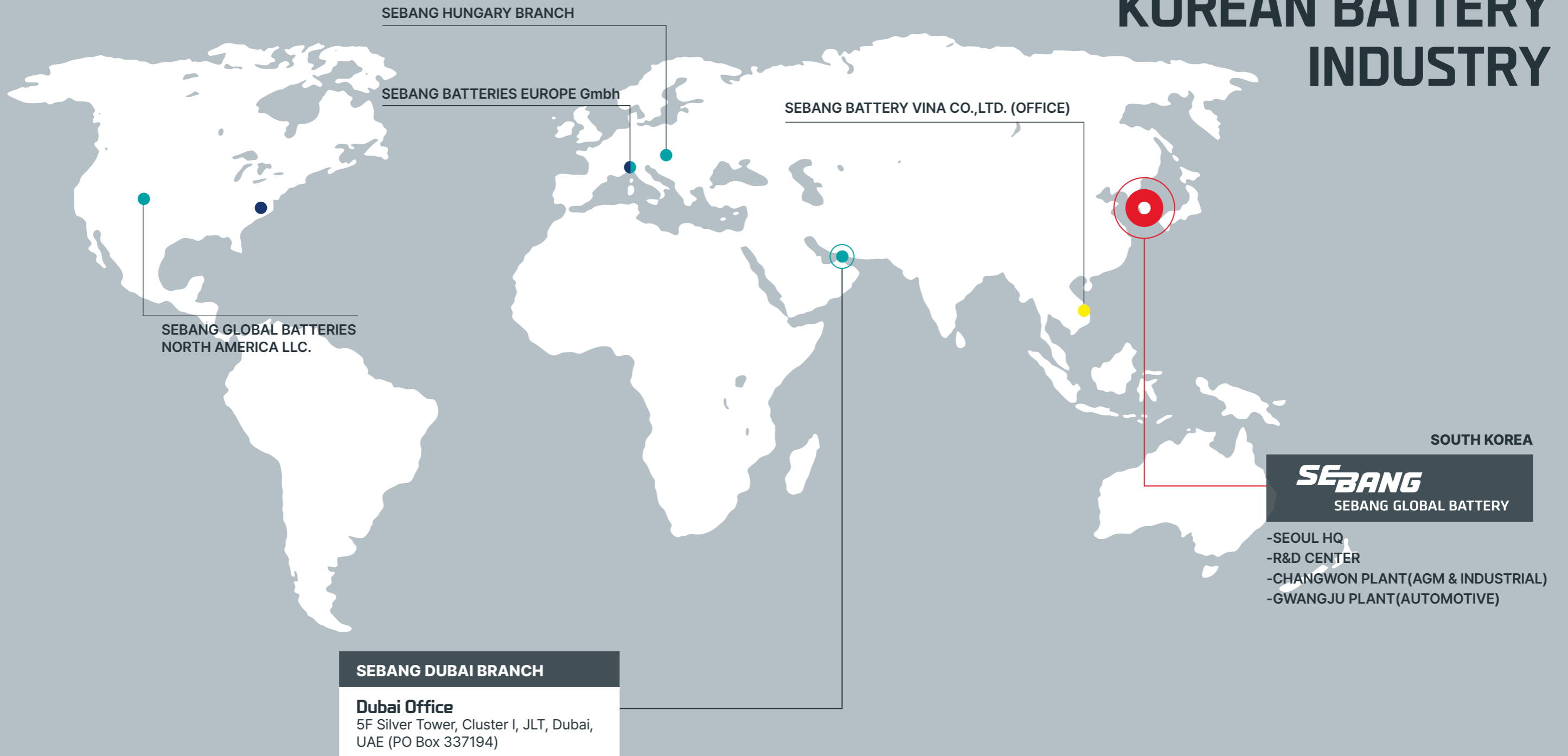

- HQ and Main Plants : South Korea (Automotive, Industrial)
- Overseas Branches : USA, Germany, Hungary, U.A.E
- Warehouses : USA, Germany

CHAPTER 02.

“

**SEBANG GLOBAL BATTERY' s
half-century of accumulated
experience and unique
technology is contained
within its products**

”

TECHNOLOGIES

- SMF
- AGM & EFB
- PREMIUM BATTERY

SMF

CONVENTIONAL



Battery that protects cars from extreme environments.

As our flagship product, it has been selected as the best battery by consumers for a long time and has been steadily upgrading to meet consumers' expectations for performance.



Improved starting performance with a special calcium alloy grid and high purity refined water that prevents lifespan degradation at high temperatures and ensures strong starting performance even in extreme environments.



Minimized self-discharge and maximized recovery performance with new materials: special tissue and special alloy. (HTC)



With a fully sealed structure and a labyrinth water recovery system, we have achieved a completely maintenance-free (MF) design that eliminates any electrolyte leakage and requires no maintenance.

COMPARISON

SMF / EFB / AGM

	SMF (STANDARD)	EFB (ENHANCED FLOODED BATTERY)	AGM (ABSORBENT GLASS MAT)
VEHICLE SYSTEM	-	ENGINE START/STOP	· ENGINE START/STOP · REGENERATIVE BRAKING SYSTEM · ENHANCED POWER CONTROL SYSTEM
VEHICLE APP.	STANDARD TYPE	SMALL -MID SIZE START/STOP	PREMIUM & DIESEL TYPE START/STOP
FUEL EFFICIENCY	-	ABOUT 2~5% ↑	ABOUT 5~10% ↑
TYPE	FLOODED		ABSORBENT GLASS MAT
FUNCTION	SLI	· MULTIPLE REPETITIVE START · LIMITED(SHORT TERM) ENGINE STOP	· MULTIPLE REPETITIVE START · LONG TERM ENGINE STOP
CCA	100% (STD)	150%(VS STD)	165%(VS STD)
LIFE CYCLE	100% (STD)	200%(VS STD)	300%(VS STD)

As a leading battery technology company

Sebang Global Battery is committed to continuous research and development, focusing on performance enhancement and product development of premium batteries such as the AGM series and EFB series for vehicles that provide charging-importance, durability, and longevity, which are used in Start-Stop vehicles

1 Indicator

Indicator shows the charging and discharging status of the battery. "Green" means charged, "Black" means discharged (requires re-charging), and "White" means replacement needed.

INDICATOR ● OK ● CHARGE ● REPLACE

2 Double lid with labyrinth structure

- Prevent electrolyte losses by collection and returning liquid to the reservoir.
- Vents allow the battery to "breathe" during temperature changes and charging.



3 Flame Arrester

- Safety system
- Prevent the explosion from spark of outside
- Minimize the acid-leakage
- Prevent the inflow of dust

4 Lead-Calcium Grids

- Offer considerable strength
- Resistant to grid corrosion
- Over-charge resistant
- Minimal gassing and water usage
- Less self-discharge
- Resist thermal runaway

Grid Technology

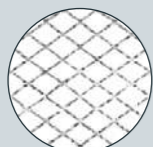

Expanded Grid



Punched Grid

Creating sub grain boundary which provide longer life span against corrosion.

- Good for endurance life span
- High corrosion resistant
- High conductivity

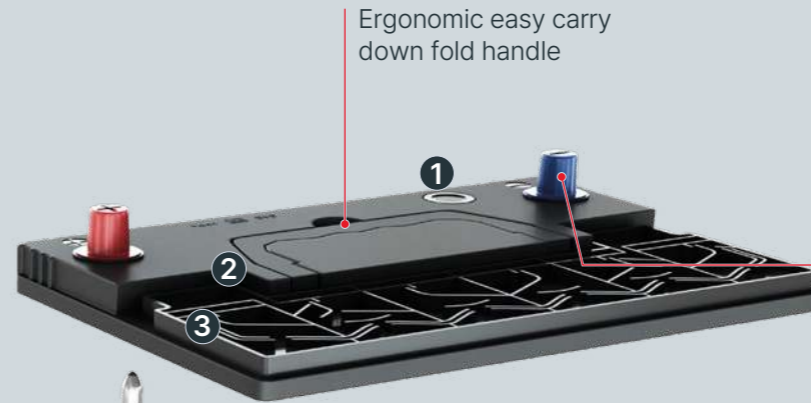

Ergonomic easy carry down fold handle

Cold forging terminal

High strength from fine structure and prevent the leakage

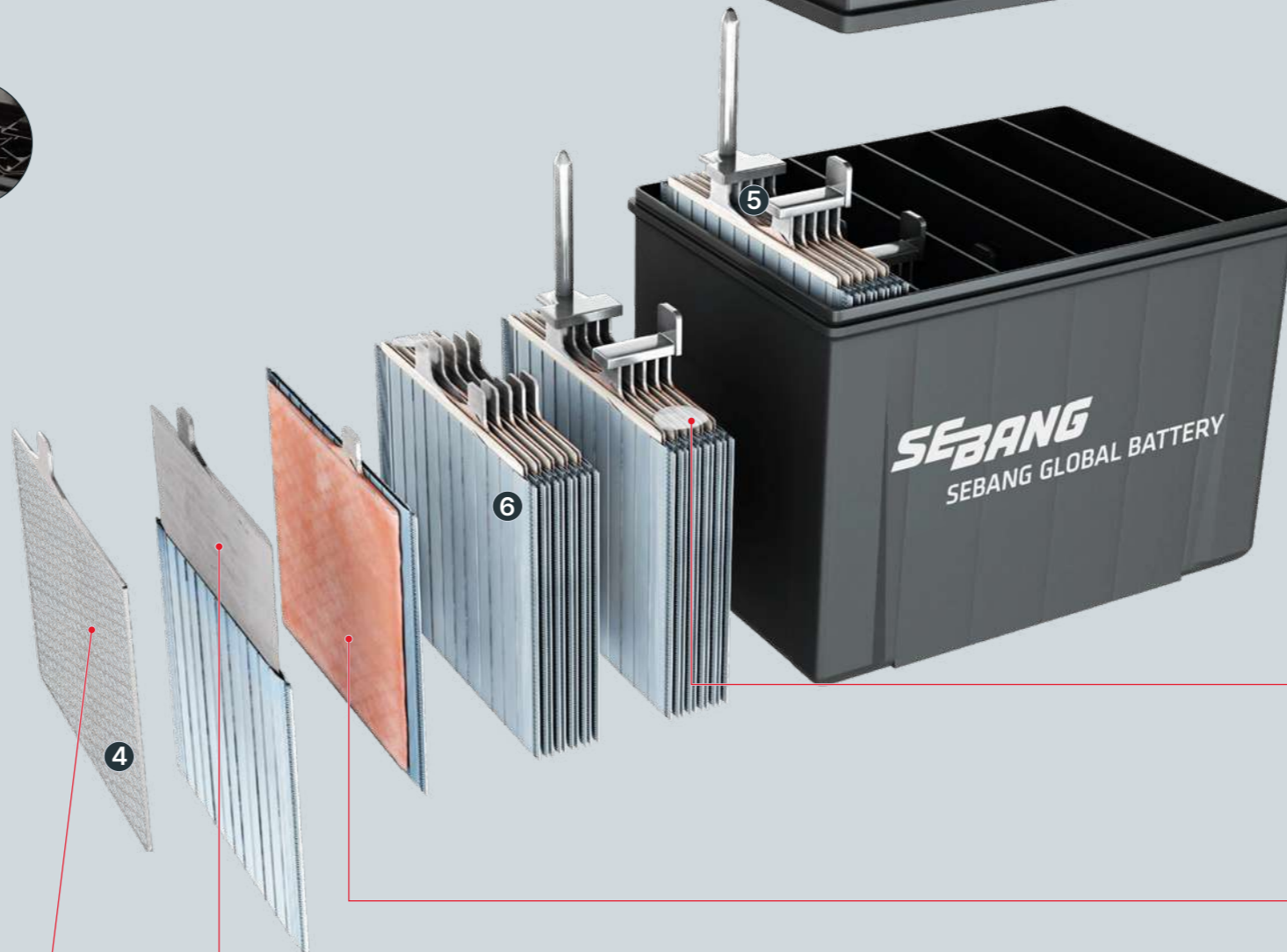

5 Centered Cast-on Plate Straps

- Stronger than the thinner gas-burned conventional connectors.
- Reduce the lever action movement resulting from road shock.

6 Low-Resistance Envelope Separators

- Encapsulate negative plates
- Prevent "treeing" and internal shorting between positive and negative plates.

Hot-melting



Hot melt or Bonding

- Strong vibration durability and long life in the automobile
- Improve resistance of tough road condition

Special additives



High density active material with special additives

- Improve charge acceptance
- Good for retention from deep discharge state

NST Special Tissue for positive pastes



Prevent the active material shedding from frequent charging and discharging.

- Offer good adhesion of active mass on the plate
- Strong resistance of Acid
- Improve of endurance life cycle

SEBANG GLOBAL BATTERY'S half-century of accumulated experience and unique technology is contained within its products



MEDIUM-SIZED BATTERY COMPARISON

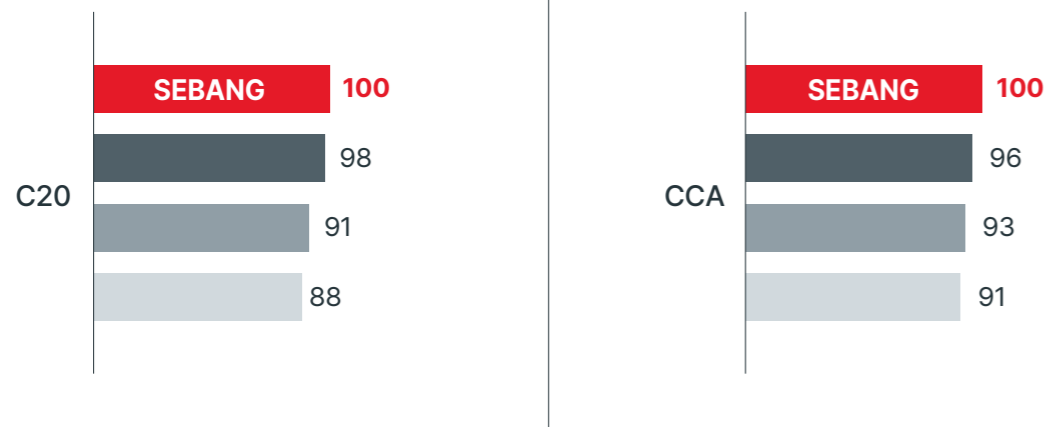
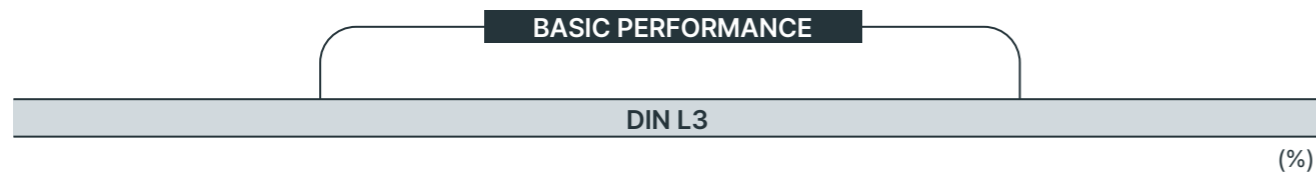

Index | ● SEBANG ● A ● B ● C

COMMERCIAL (HEAVY DUTY) BATTERY for trucks and buses is a battery with technology accumulated over half a century



HEAVY DUTY BATTERY COMPARISON

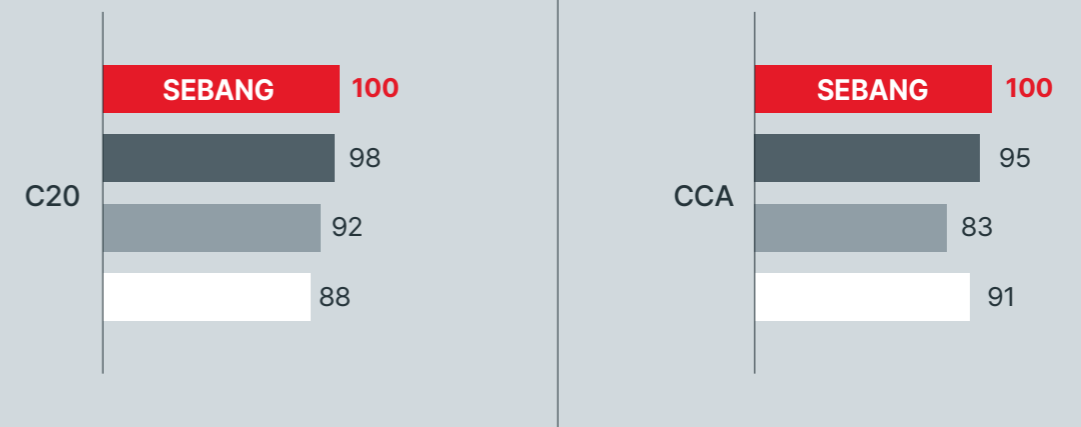
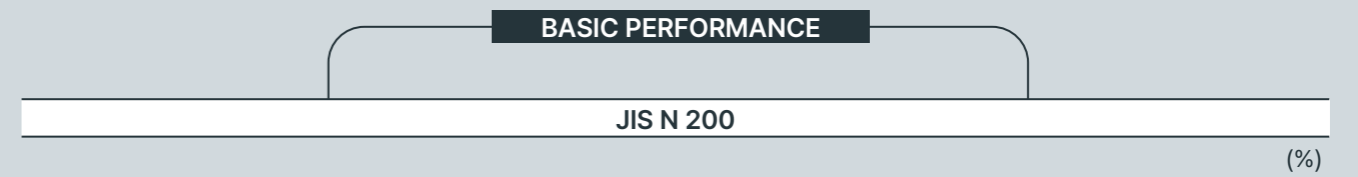

Index | ● SEBANG ● A ● B ● C

SEBANG GLOBAL BATTERY is the NO.1 battery brand in South Korea and recognized worldwide



AGM & EFB

START & STOP

The **AGM battery** is a next-generation vehicle battery developed for vehicles equipped with SMART power generation control systems. In traditional vehicles, the battery was only used briefly for providing starting current for the engine and 12V power for accessories like radio, lights, AC compressors, and the charging was done by sending a continuous current to maintain a fully charged state while driving, which lowered energy efficiency and fuel economy. However, most modern vehicles now have SMART power generation control systems installed to improve fuel efficiency. Since charging is intermittent, tailored to the battery's remaining capacity, fuel efficiency has been improved, but battery usage has increased. Therefore, equipping vehicles with AGM products optimized to manage various functions and sustain more cycles compared to conventional batteries is helpful in increasing economy. AGM batteries have a longer product life and improved safety by its non-spillable nature and the use of dedicated lead plates and absorbent glass mat.

EFB battery is suitable for small and midsize vehicles with start-stop systems and no regenerative braking system. They have a longer lifespan than standard batteries and provide effects such as reduced gas emissions and improved vehicle convenience features, similar to AGM batteries.

AGM (Absorbent Glass Mat)

	AUTO STOP	Improved stratification of electric poles, substrates, active materials, and electrolytes optimized for AUTO STOP system application
	ELECTROLYTE ABSORPTION	Application of PUNCH substrate to prevent leakage by absorbing electrolyte, high-density hygroscopic GLASS MAT separator, glass fiber mat
	REUNION	Recombination of gases occurring inside the battery
	VALVE REGULATED	Application of VALVE REGULATED using one-way valve
	IMPROVE FUEL EFFICIENCY	Car manufacturers are adapting new technologies like Start & Stop and Regenerative Braking System, which requires significant energies from battery. Sebang Global AGM batteries are suitable for these applications and let you save fuel 5~10%.
	CO2 REDUCTION	Reducing the CO2 emission is key task of car industry. Coping with climate change and resource depletion, we all care for Earth, Green Globe. Sebang Global AGM battery is supporting human kind's efforts with the most advanced technologies which are reliable for this purpose.
	OE QUALITY + CHARGING RELIABILITY	Sebang Global Battery produces AGM batteries at a dedicated production line where we produce the original equipment and after-market batteries which guarantee the best quality with OE requirements. Sebang Global Battery meets the highest environmental standards at every stage of the manufacturing process. Sebang Global Battery ensures that you get the OE quality standard product.
	ECO FRIENDLY	If you can't plant a tree in your garden, plant Sebang Global AGM battery in your car. It creates energy and saves CO2 as tree does.

AGM

- VALVE CAP**
 - Control internal pressure
 - Hydrogen recombination
- POSITIVE PLATE**
 - High Density Active Material
 - Fine & Uniform 4BS
- NEGATIVE PLATE**
 - High Charge acceptance
 - Low water consumption
- CASE**
 - Reinforced design is precisely tailored to support battery elements.
 - Material is exceptionally strong, durable and withstands the shock and vibration from road
- CAST-ON-STRAP**
 - Stronger than the thinner gas-burned conventional connectors.
 - Reduce the lever action movement resulting from road shock
- ABSORBED GLASS MAT SEPARATOR**
 - Low Resistance & High Density
 - High Ionic Conductivity

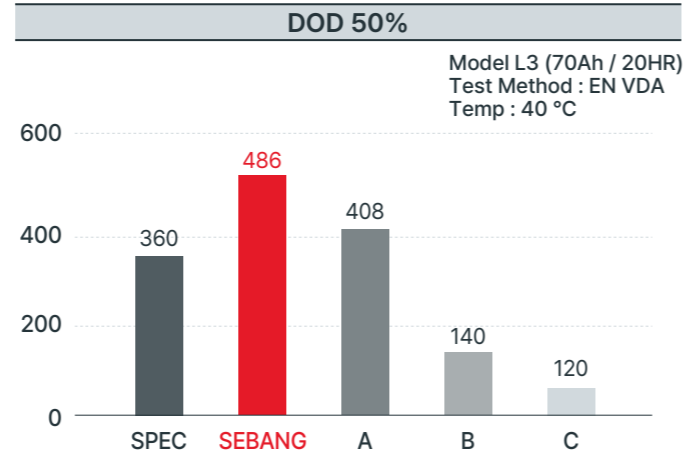
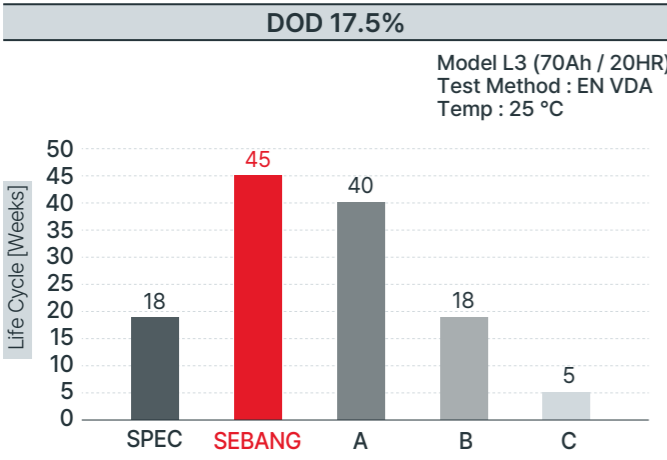

EFB

- SPECIAL DOUBLE LID**
 - Anti-leakage structure
 - Proof against 50° tilt
- GRID TECHNOLOGY**
 - Creating sub grain boundary which provide longer life span against corrosion.
 - Good for endurance life span
 - High corrosion resistant
 - High conductivity
- Expanded Grid** (Image)
- Punched Grid** (Image)
- HIGH PURE ELECTROLYTE**
 - Low water loss
- ELECTROLYTE DDITIVES**
 - Increase deep discharge cycle performance
- MIXING ELEMENT**
 - Prevent stratification (Option for European/DIN Types)
- SPECIAL ADDITIVES**
 - Improved charging acceptance
- SPECIAL ORGANIC FIBER**
 - High Life Cycle

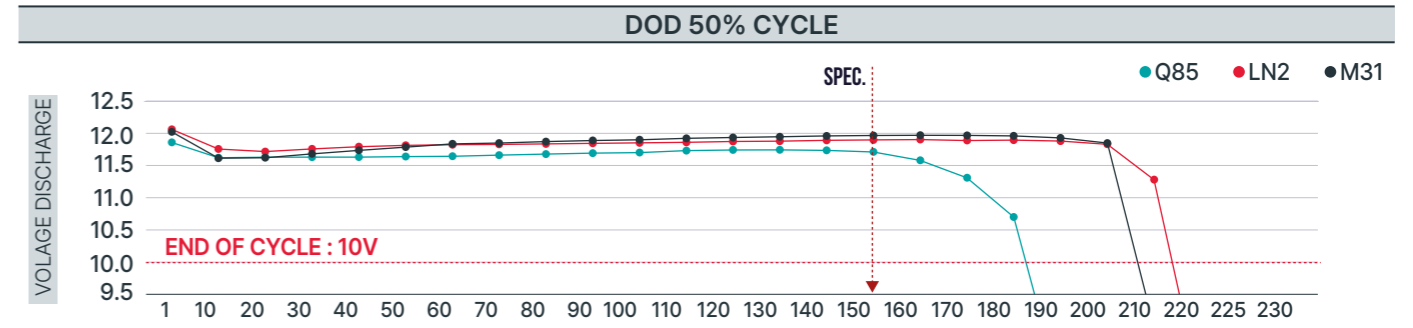

Category	EFB Q85		EFB LN2		EFB LN3		
	Specifications	Test Results	Specifications	Test Results	Specifications	Test Results	
PERFORMANCE	C20	73 Ah	73.8 Ah	60 Ah	65.2 Ah	70 Ah	75.4 Ah
	SAE CCA	7.2 V (660 A)	7.42 V	7.2 V (560 A)	7.48 V	7.2 V (650 A)	7.51 V
LIFE CYCLE	DOD 50 %	150 cycle	183 cycle	150 Cycle	214 Cycle	150 Cycle	209 Cycle

WHAT IS AMS? (ALTERNATOR MANAGEMENT SYSTEM)

Controls the alternator voltage variably depending on the vehicle operating conditions to improve vehicle fuel efficiency.

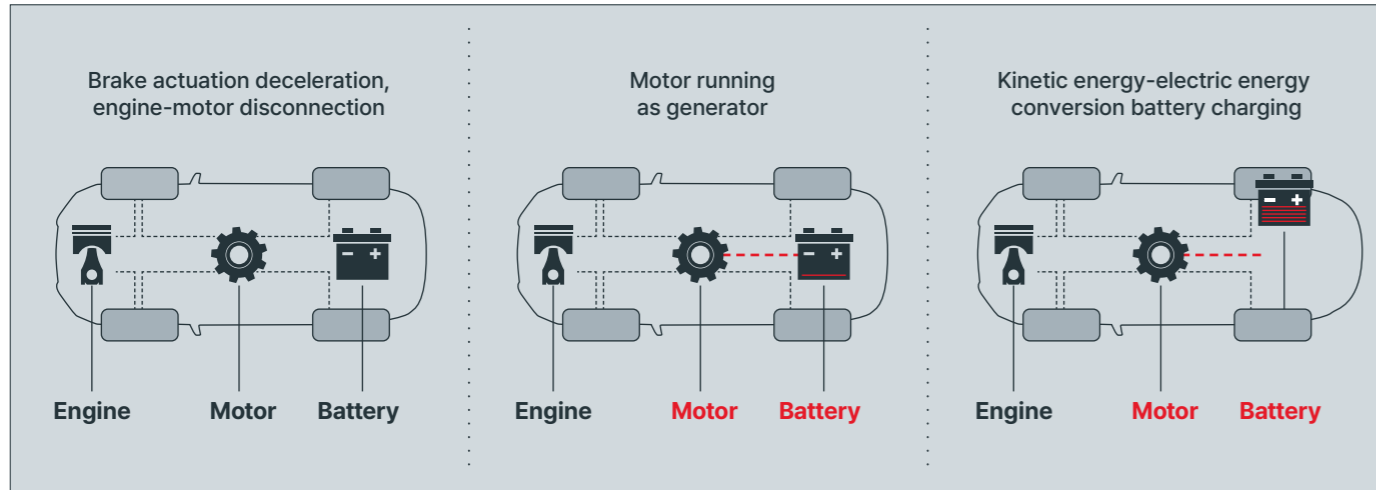

The alternator management system detects vehicle operating conditions, electrical loads, and battery charging status to control the alternator's voltage through the Engine Control Module (ECM), thereby improving fuel efficiency and maintaining optimal battery charging status. It performs charging control, discharging control, and normal control depending on the battery's charging status and driving conditions. During acceleration, it performs discharging control to consume battery power and reduce the alternator's voltage to reduce its workload, while during deceleration, it performs charging control to increase the alternator's voltage and replenish the consumed battery voltage.

AGM BATTERY SERIES

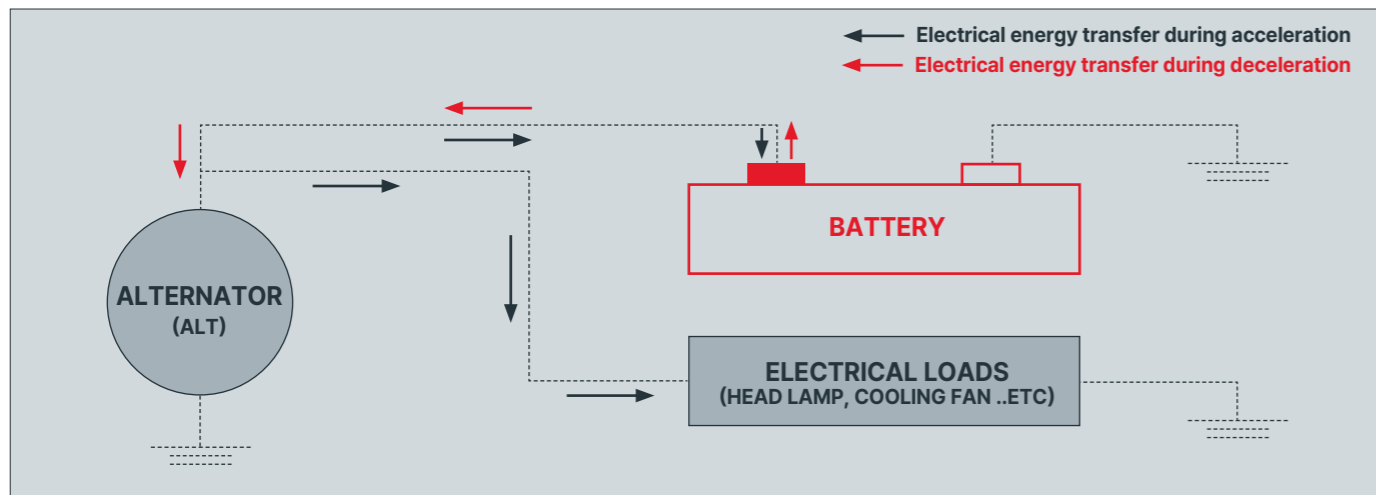

MAJOR COMPONENTS

- ALTERNATOR (ALT)** Produces electrical energy and supplies power to the battery and electrical loads
- BATTERY** Supplies power to start the vehicle and supports the alternator during operation
- ELECTRICAL LOADS** Devices that consume electrical energy, such as ignition systems, lighting systems, and control units

HOW DOES THE ALTERNATOR MANAGEMENT SYSTEM WORK?

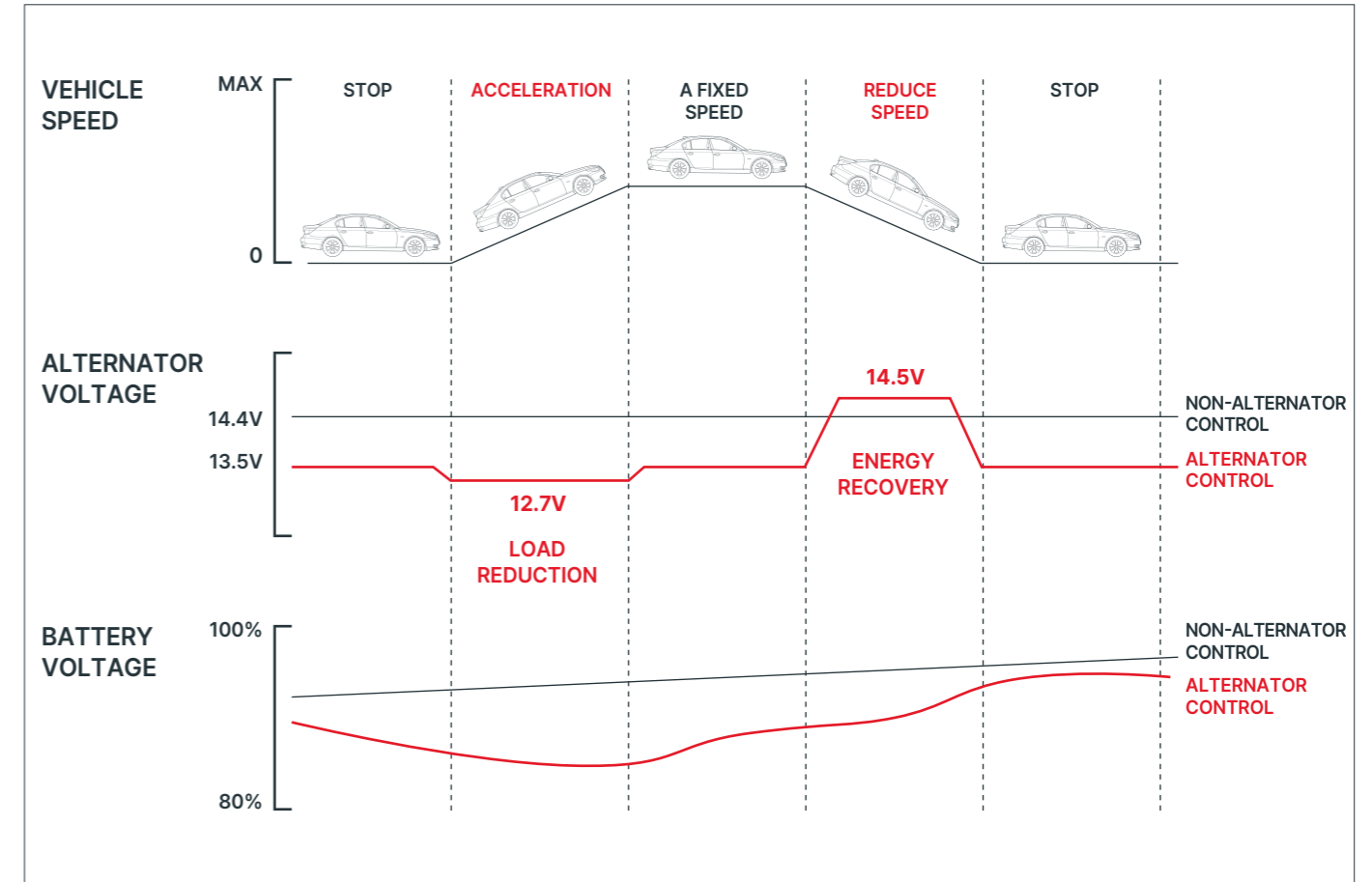

BASIC PRINCIPLE

The movement of electrical energy by potential difference. (from high potential to low potential)

NON-ALTERNATOR CONTROL VEHICLE

Continues to charge with a fixed voltage of 14.4V regardless of vehicle operating conditions. (-35mA/°C is applied when the temperature rises)

ALTERNATOR CONTROL VEHICLE

During vehicle acceleration, to reduce the engine's load, the alternator's voltage is lowered to 12.7V, Battery's OCV becomes 12.8-12.9V, which causes a potential difference, discharging the battery.

*Discharging occurs only when the battery voltage is above 12.7V, and charging occurs when it is below 12.7V

VEHICLE DECELERATION

During vehicle deceleration, the alternator's voltage is increased to 14.5V to create a potential difference, charging the battery. (energy recovery)

PRODUCT LINE UP

BOX & LABEL DESIGN

AGM



EFB



SMF



BARND AD

POSTER DESIGN

TYPE-1



TYPE-2

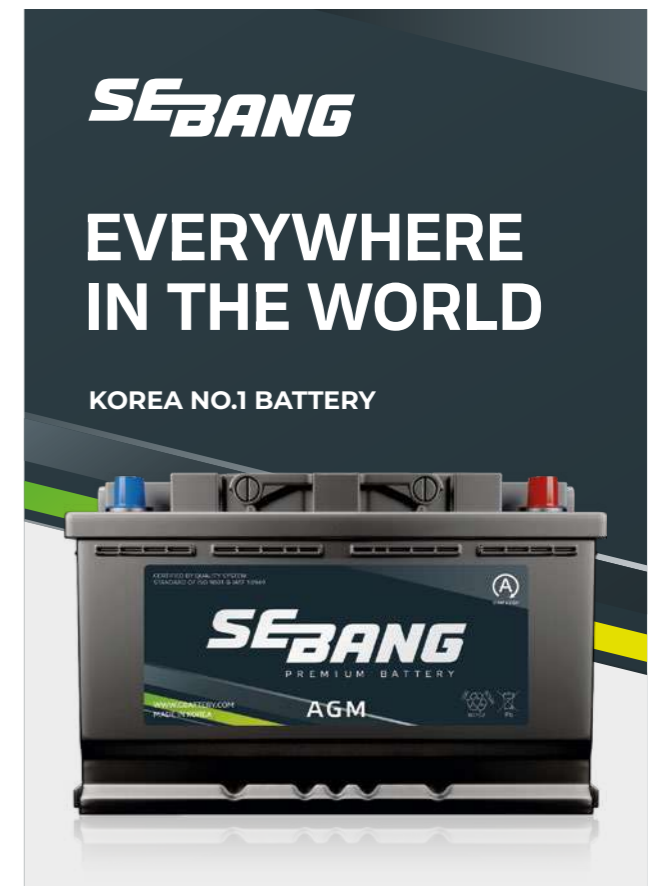

CHAPTER 03.

“

SEBANG GLOBAL BATTERY
is the no.1 battery brand
in South Korea and
recognized worldwide.

”

PRODUCT RANGES

- JIS
- DIN
- BCI
- AGM
- EFB
- GOLF CART



JIS TYPE

**JAPANESE INDUSTRIAL STANDARDS TYPE
CALCIUM MF BATTERY**



CELL LAYOUT

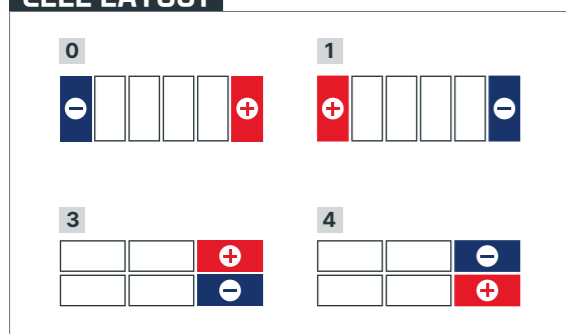

SEALED MAINTENANCE FREE BATTERY(ASIA)

PASSENGER CAR & LIGHT COMMERCIAL BATTERY

OLD JIS	NEWS JIS	DIMENSIONS(MM)			VOLTAGE (V)	CAPACITY(AH)		RC (MIN)	CCA (-18°C)	CA (0°C)	LAYOUT	TERMINAL	HANDLE
		L	W	TH		5HR	20HR						
B17	SMF 34B17L	167	127	227	12	27	33	47	280	390	0	SM	P/H
	SMF 34B17R	167	127	227	12	27	33	47	280	390	1	SM	P/H
SMF NS40ZL	SMF 40B19L	187	127	226	12	27	35	49	300	410	0	SM	P/H
SMF NS40Z	SMF 40B19R	187	127	226	12	27	35	49	300	410	1	SM	P/H
SMF NS40ZLS	SMF 40B19LS	187	127	226	12	27	35	49	300	410	0	STD	P/H
SMF NS40ZS	SMF 40B19RS	187	127	226	12	27	35	49	300	410	1	STD	P/H
SMF NX100-S6L	SMF 55B24L	238	129	225	12	36	45	80	430	540	0	SM	P/H
SMF NX100-S6	SMF 55B24R	238	129	225	12	36	45	80	430	540	1	SM	P/H
SMF NX100-S6LS	SMF 55B24LS	238	129	225	12	36	45	80	430	540	0	STD	P/H
SMF NX100-S6S	SMF 55B24RS	238	129	225	12	36	45	80	430	540	1	STD	P/H
SMF 50D20L	SMF 50D20L	202	173	225	12	42	50	85	450	590	0	STD	P/H
SMF 50D20R	SMF 50D20R	202	173	225	12	42	50	85	450	590	1	STD	P/H
D23	SMF 55D23L	232	173	225	12	48	60	100	500	630	0	STD	P/H
	SMF 55D23R	232	173	225	12	48	60	100	500	630	1	STD	P/H
	SMF 75D23L	232	173	225	12	52	65	110	580	710	0	STD	P/H
	SMF 75D23R	232	173	225	12	52	65	110	580	710	1	STD	P/H
SMF N50L	SMF 48D26L	260	173	222	12	40	50	80	420	550	0	STD	P/H
SMF N50	SMF 48D26R	260	173	222	12	40	50	80	420	550	1	STD	P/H
SMF N50ZL	SMF 55D26L	260	173	222	12	48	60	100	500	630	0	STD	P/H
SMF N50Z	SMF 55D26R	260	173	222	12	48	60	100	500	630	1	STD	P/H
SMF NX110-5L	SMF 80D26L	260	173	222	12	56	70	120	600	730	0	STD	P/H
SMF NX110-5	SMF 80D26R	260	173	222	12	56	70	120	600	730	1	STD	P/H
SMF N70L	SMF 65D31L	303	173	225	12	56	70	105	560	690	0	STD	P/H
SMF N70	SMF 65D31R	303	173	225	12	56	70	105	560	690	1	STD	P/H
SMF N70ZL	SMF 75D31L	303	173	225	12	60	75	120	630	760	0	STD	P/H
SMF N70Z	SMF 75D31R	303	173	225	12	60	75	120	630	760	1	STD	P/H
SMF NX120-7L	SMF 95D31L	303	173	225	12	72	90	150	750	880	0	STD	P/H
SMF NX120-7	SMF 95D31R	303	173	225	12	72	90	150	750	880	1	STD	P/H

*B3 BHD is available by customer's request

*Specifications are subject to change without notice.

SEALED MAINTENANCE FREE BATTERY(ASIA)

HEAVY-DUTY COMMERCIAL BATTERY

OLD JIS	NEWS JIS	DIMENSIONS(MM)			VOLTAGE (V)	CAPACITY(AH)		RC (MIN)	CCA (-18°C)	CA (0°C)	LAYOUT	TERMINAL	HANDLE
		L	W	TH		5HR	20HR						
SMF 1000LA		330	173	240	12	80	100	182	870	1000	0	STD	P/H
SMF 1000RA		330	173	240	12	80	100	182	870	1000	1	STD	P/H
SMF 1000LS		330	173	240	12	80	100	182	870	1000	0	STD	P/H
SMF 1000RS		330	173	240	12	80	100	182	870	1000	1	STD	P/H
SMF N100L	SMF 95E41L	410	175	235	12	80	100	180	730	860	0	STD	R/N
SMF N100	SMF 95E41R	410	175	235	12	80	100	180	730	860	1	STD	R/N
SMF N120L		505	183	240	12	96	120	230	820	950	4	STD	R/N
SMF N120		505	183	240	12	96	120	230	820	950	3	STD	R/N
SMF N150L		508	222	241	12	120	150	300	1000	1130	4	STD	R/N
SMF N150		508	222	241	12	120	150	300	1000	1130	3	STD	R/N
SMF N200L		523	279	248	12	160	200	430	1150	1280	4	STD	R/N
SMF N200		523	279	248	12	160	200	430	1150	1280	3	STD	R/N

*B3 BHD is available by customer's request

*Specifications are subject to change without notice.



DIN TYPE

DEUTSCHES INSTITUT FÜR NORMUNG TYPE CALCIUM MF BATTERY



CELL LAYOUT

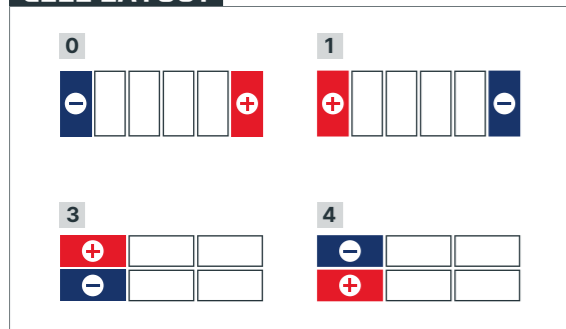

SEALED MAINTENANCE FREE BATTERY(EUROPE)

PASSENGER CAR & LIGHT COMMERCIAL BATTERY

TYPE	MODEL	DIMENSIONS(MM)			VOLTAGE (V)	CAPACITY 20HR(AH)	RC (MIN)	CCA(-18°C)		LAYOUT	TERMINAL	BHD
		L	W	TH				SAE	EN			
LO	SMF 54018	175	175	190	12	40	70	350	330	0	STD	B3
	SMF 53529	211	175	175	12	35	52	340	340	0	STD	B3
LB1	SMF 54316	211	175	175	12	43	70	420	420	0	STD	B3
	SMF 54317	211	175	175	12	43	70	420	420	0	FORD	B3
L1	SMF 54459	208	175	190	12	44	71	350	330	0	STD	B3
	SMF 54464	208	175	190	12	44	71	350	330	1	STD	B3
LB2	SMF 54519	245	175	175	12	45	80	420	420	0	STD	B4
	SMF 55040	245	175	175	12	50	86	460	460	0	STD	B3
	SMF 55457	245	175	175	12	54	94	510	510	0	STD	B3
	SMF 55458	245	175	175	12	54	94	510	510	1	STD	B3
	SMF 55459	245	175	175	12	54	94	510	510	0	FORD	B3
	SMF 56220	245	175	175	12	62	100	540	540	0	STD	B3
L2	SMF 55559	245	175	190	12	55	94	480	440	0	STD	B3
	SMF 55565	245	175	190	12	55	94	480	440	1	STD	B3
	SMF 56219	245	175	190	12	62	100	510	480	0	STD	B3
	SMF 56217	245	175	190	12	62	100	510	480	1	STD	B3
LB3	SMF 56048	269	174	226	12	60	100	500	460	0	STD	B9
	SMF 56049	269	174	226	12	60	100	500	460	1	STD	B9
	SMF 57029	269	174	226	12	70	120	600	560	0	STD	B9
	SMF 57024	269	174	226	12	70	120	600	560	1	STD	B9
	SMF 55414	277	175	175	12	54	94	510	510	0	STD	B3/B4
	SMF 55415	277	175	175	12	54	94	510	510	1	STD	B3/B4
	SMF 56318	277	175	175	12	63	110	580	580	0	STD	B4
	SMF 56323	277	175	175	12	63	110	580	580	0	FORD	B3
LB4	SMF 56330	277	175	175	12	63	110	580	580	0	STD	B3
	SMF 57113	277	175	175	12	71	115	620	620	0	STD	B3
	SMF 57114	277	175	175	12	71	115	620	620	0	FORD	B3
	SMF 56638	277	175	190	12	66	110	580	540	0	STD	B3
	SMF 57220	277	175	190	12	72	120	620	580	0	STD	B3
	SMF 57219	277	175	190	12	72	120	620	580	1	STD	B3
L3	SMF 57820	277	175	190	12	78	140	700	660	0	STD	B3
	SMF 58014	315	175	175	12	80	135	730	730	0	STD	B3
L4	SMF 59042	315	175	190	12	90	160	780	720	0	STD	B3
	SMF 59043	315	175	190	12	90	160	780	720	1	STD	B3
LB5	SMF 58515	353	175	175	12	85	140	740	700	0	STD	B3
	SMF 59015	353	175	175	12	90	156	820	820	0	STD	B3
L5	SMF 58827	353	175	190	12	88	148	730	700	0	STD	B3
	SMF 59218	353	175	190	12	92	160	780	740	0	STD	B3
	SMF 60044	353	175	190	12	100	170	850	820	0	STD	B3
MAC	SMF 61023	514	175	210	12	110	215	800	800	3	STD	B3
	SMF 63541	514	175	210	12	135	250	910	910	3	STD	B3
SHD A	SMF 64020SHD	513	189	223	12	140	260	800	800	3	STD	B0/B3
	SMF 64028SHD	513	189	223	12	140	260	800	800	4	STD	B0/B3
SHD B	SMF 67018SHD	513	222	220	12	170	330	900	900	3	STD	B0/B3
	SMF 67019SHD	513	222	220	12	170	330	900	900	4	STD	B0/B3
	SMF 68032SHD	513	222	220	12	180	350	950	950	3	STD	B0/B3
	SMF 68033SHD	513	222	220	12	180	350	950	950	4	STD	B0/B3
SHD C	SMF 68021SHD	518	273	241	12	180	350	950	950	3	STD	B0
	SMF 70027SHD	518	273	241	12	200	390	1150	1150	3	STD	B0
	SMF 73011SHD	518	273	241	12	230	430	1200	1200	3	STD	B0

*B3 BHD is available by customer's request

*Specifications are subject to change without notice.



BCI TYPE

**BATTERY COUNCIL INTERNATIONAL TYPE
CALCIUM MF BATTERY**



CELL LAYOUT

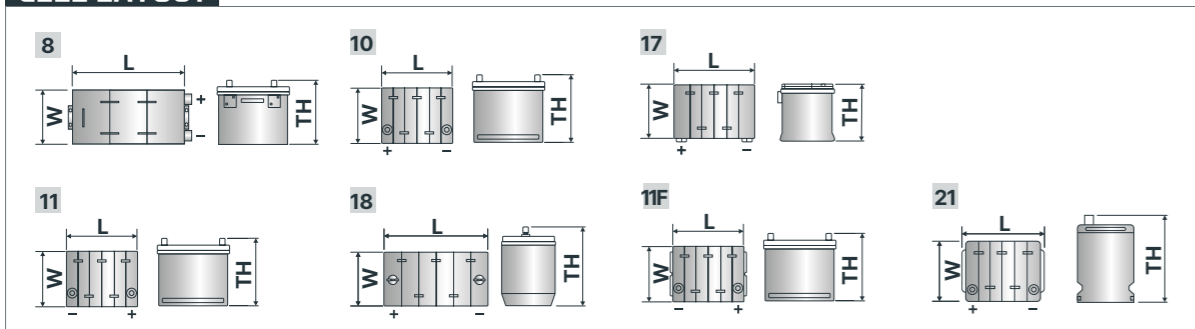

A. PASSENGER CAR & LIGHT COMMERCIAL BATTERIES

GROUP	MODEL	DIMENSIONS(MM)			VOLTAGE (V)	CAPACITY(AH)		RC	CCA (A)	CA (A)	FIGURE NO.	TERMINAL
		L	W	TH		5HR	20HR					
58	SMF 58-450	236	183	177	12	40	50	74	450	560	21	STD
	SMF 58-530	236	183	177	12	48	60	86	530	660	21	STD
65	SMF 65-660	305	190	191	12	58	72	120	660	780	21	STD
	SMF 65-700	305	190	191	12	62	78	130	700	830	21	STD
22F	SMF 65-820	305	190	191	12	70	88	140	820	930	21	STD
	SMF 22F-470	240	174	205	12	40	50	86	470	590	11F	STD/DUAL
26	SMF 22F-530	240	174	205	12	43	54	95	530	650	11F	STD/DUAL
	SMF 26-420	208	171	205	12	34	42	60	420	550	10	STD
70	SMF 26-560	208	171	205	12	43	54	86	560	690	10	STD
	SMF 70-420	208	179	185	12	34	42	60	420	550	17	SIDE
70DT	SMF 70-560	208	179	185	12	43	54	86	560	690	17	SIDE
	SMF 70DT-420	208	179	205	12	34	42	60	420	550	10,17	DUAL
86	SMF 70DT-560	208	179	205	12	43	54	86	560	690	10,17	DUAL
	SMF 86-520	231	171	205	12	40	50	79	520	650	10	STD
75	SMF 86-710	231	171	205	12	53	66	110	710	840	10	STD
	SMF 75-520	231	179	185	12	40	50	79	520	650	17	SIDE
75DT	SMF 75-710	231	179	185	12	53	66	110	710	840	17	SIDE
	SMF 75DT-520	231	179	205	12	40	50	78	520	650	10,17	DUAL
34	SMF 75DT-710	231	179	205	12	53	66	110	710	840	10,17	DUAL
	SMF 34-615	260	171	205	12	46	58	94	615	745	10	STD
78	SMF 34-780	260	171	205	12	59	74	124	780	910	10	STD
	SMF 78-615	260	179	185	12	46	58	94	615	745	17	SIDE
78DT	SMF 78-780	260	179	185	12	59	74	124	780	910	17	SIDE
	SMF 78DT-615	260	179	205	12	46	58	94	615	745	10,17	DUAL
	SMF 78DT-780	260	179	205	12	59	74	124	780	910	10,17	DUAL

*More or less CCA Batteries are available up on customer's request

*Specifications are subject to change without notice.

B. HEAVY-DUTY COMMERCIAL BATTERIES

GROUP	MODEL	DIMENSIONS(MM)			VOLTAGE (V)	CAPACITY(AH)		RC	CCA (A)	CA (A)	FIGURE NO.	TERMINAL
		L	W	TH		5HR	20HR					
31S	SMF 31-730S	330	173	240	12	68	85	150	730	860	18	STUD
	SMF 31-1000S	330	173	240	12	96	120	205	1000	1150	18	STUD
31A	SMF 31-730A	330	173	240	12	68	85	150	730	860	18	STD
	SMF 31-1000A	330	173	240	12	96	120	205	1000	1150	18	STD
30H	SMF 30H-830	330	173	229	12	80	100	180	830	960	10	STD
	SMF 30HL-830	330	173	229	12	80	100	180	830	960	10	STD
4D	SMF 4D-850	508	222	241	12	112	140	270	850	980	8	STD
	SMF 4D-1000	508	222	241	12	120	150	300	1000	1080	8	STD
8D	SMF 8D-1200	523	279	250	12	144	180	315	1200	1330	8	STD
	SMF 8D-1400	523	279	250	12	160	200	400	1400	1530	8	STD

*More or less CCA Batteries are available up on customer's request

*Specifications are subject to change without notice.

C. GENERAL UTILITY & MARINE BATTERIES

GROUP	MODEL	DIMENSIONS(MM)			VOLTAGE (V)	CAPACITY(AH)		RC	CCA (A)	CA (A)	FIGURE NO.	TERMINAL
		L	W	TH		5HR	20HR					
U1	SMF U1-250	195	130	183	12	18	23	35	250	360	10	LUG
	SMF U1-330	195	130	183	12	24	30	45	330	440	10	LUG
U1R	SMF U1R-250	195	130	183	12	18	23	35	250	360	11	LUG
	SMF U1R-330	195	130	183	12	24	30	45	330	440	11	LUG
M24	SMF 24MS-500	260	174	222	12	52	65	85	500	630	10	TM
	SMF 24MS-680	260	174	222	12	64	80	115	680	810	10	TM
M27	SMF 27MS-730	304	173	225	12	72	90	125	730	860	10	TM
	SMF 27MS-780	304	173	225	12	76	95	130	780	910	10	TM
M31	SMF 31MS-850	330	173	240	12	80	100	180	850	980	18	TM
	SMF 24HCM-500	260	174	222	12	56	70	130	500	630	10	TM
24HCM	SMF 24HCM-600	260	174	222	12	66	82	140	600	730	10	TM
	SMF 27HCM-660	304	173	225	12	70	88	160	660	790	10	TM
27HCM	SMF 27HCM-700	304	173	225	12	76	95	170	700	830	10	TM
	SMF 31HC-780	330	173	240	12	80	100	180	700	830	18	STD/STUD

*More or less CCA Batteries are available up on customer's request

*Specifications are subject to change without notice.



AGM TYPE

ABSORBENT GLASS MAT

TYPE	DIMENSIONS(MM)			LAYOUT	BCI ASSEMBLY FIGURE	HOLD-DOWN	PERFORMANCE		
	LENGTH MM	WIDTH MM	HEIGHT MM				20HR	RC	CCA
LN1(H4)	206	175	190	0	24	B3	50	80	540
LN2(H5)	242	175	190	0	24	B3	60	100	640
LN3(H6)	277	175	190	0	24	B3	70	120	760
LN4(H7)	317	175	190	0	24	B3	80	140	800
LN4(H7) R TYPE	317	175	190	1	24	B3	80	140	800
LN5(H8)	353	175	190	0	24	B3	92	160	850
LN6(H9)	394	175	190	0	24	B3	105	190	950

*Specifications are subject to change without notice.



EFB TYPE

ENHANCED FLOODED BATTERY

TYPE	SIZE	DIMENSIONS(MM)			TERMINAL	LAYOUT	PERFORMANCE		
		LENGTH MM	WIDTH MM	HEIGHT MM			20HR	RC	CCA
JIS	K42	187	127	223	STD / SMALL	0 / 1	35	60	370
	M42	197	127	223	STD / SMALL	0 / 1	35	60	370
	N55	238	129	223	STD / SMALL	0 / 1	55	80	460
	Q85	232	173	225	STD	0 / 1	65 / 73	110 / 125	550 / 660
	S95	260	174	225	STD	0 / 1	70 / 80	130 / 150	680 / 760
	T110	304	172	225	STD	0 / 1	95 / 95	150 / 170	760 / 820
DIN	LN1	208	175	190	STD	0	50	80	480 / 540
	LN2	242	175	190	STD	0	60 / 65	100 / 110	560 / 640
	LN3	277	175	190	STD	0	70 / 75	120 / 130	650 / 760
	LN4	315	175	190	STD	0	80 / 85	150 / 160	730 / 800
	LN5	353	175	190	STD	0	95 / 100	175 / 185	850 / 900
	LN6	392	175	190	STD	0	105	195	950
	LBN3	277	175	175	STD	0	65	110	650
BCI	LBN4	315	175	175	STD	0	75	135	730
	SHD B	513	222	220	STD	3 / 4	180 / 190	360 / 370	1230 / 1200
	SHD C	518	273	241	STD	3 / 4	230 / 240	400 / 420	1400 / 1350
	65	292	189	191	STD	0 / 1	75	130	750
	78	260	179	205	SIDE	0 / 1	70	120	750
M2	M24	260	174	225	TM	0 / 1	80	150	760
	M27	304	172	225	TM	0 / 1	95	170	820
	M31	330	173	240	TM	0 / 1	100	180	850

*Specifications are subject to change without notice.



GOLF CART

Longest Series is developed with Sebang Global Battery's unrivaled technology accumulated over half a century. It is a dedicated product for golf carts, electric vehicles, and unmanned transporters with the best performance.



APPLICATIONS

 [Aerial Work Platform]	 [Golf Cart]	 [Ride-on Scrubber]	 [Solar Power]
----------------------------	-----------------	------------------------	-------------------

TYPE	CAPACITY				DIMENSIONS(MM)				WEIGHT	
	@25A (min)	@75A (min)	5HR (MAh)	20HR (MAh)	LENGTH	WIDTH	HEIGHT	TOTAL HEIGHT	KG	
					MM	MM	MM	MM		
6V	L-605	338	105	175	210	259	179	245	278	26
	L-105	447	115	185	225	259	179	245	278	28
	L-125	488	132	195	240	259	179	245	278	30
	L-145	530	145	215	260	259	179	264	297	33
8V	L-875	295	75	145	170	262	181	245	278	28
	L-890	340	90	155	190	262	181	245	278	31
	L-8125	425	110	190	240	262	181	283	316	37
12V	L-1275	280	70	120	150	329	181	245	278	38

*Specifications are subject to change without notice.

CAP OPTIONS

GANG CAP

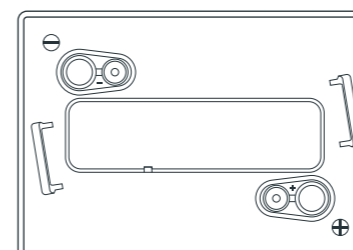

INDIVIDUAL CAPS

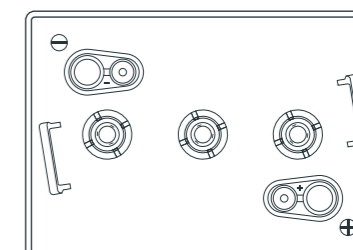

TERMINAL CONFIGURATIONS

EHPT (Embedded High Profile Terminal)

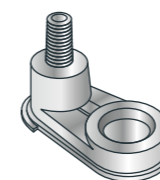

Terminal Height Inches (mm)	1.50 (38)
Torque Values in-lb (Nm)	95 - 105 (11 - 12)
Bolt	5/16"

EAPT (Embedded Automotive Post Terminal)

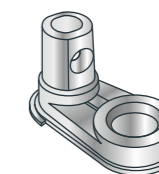

Terminal Height Inches (mm)	0.95 (24)
Torque Values in-lb (Nm)	50 - 70 (5.6 - 7.9)

CHAPTER 04.

“

**As a leading battery
technology company**

”



REFERENCES

- TECHNICAL INFORMATION
- BATTERY PRINCIPLES AND FEATURES
- PROCEDURE OF REPLACEMENT
- PRECAUTIONS

TECHNICAL INFORMATION

CELL LAYOUT / TERMINAL / BHD / BCI FIGURE

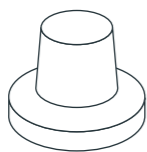
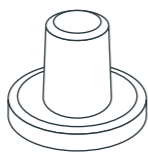
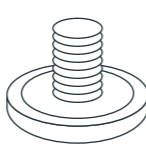
TERMINAL

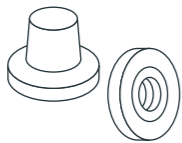
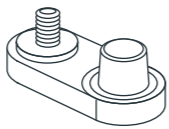
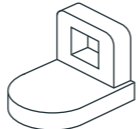
STANDARD	SMALL	STUD	SIDE
			
DUAL	TM	LUG	
			

BHD

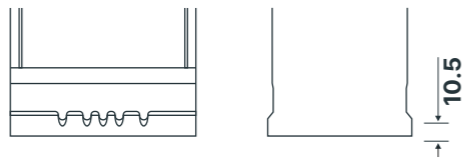
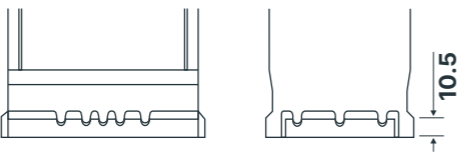
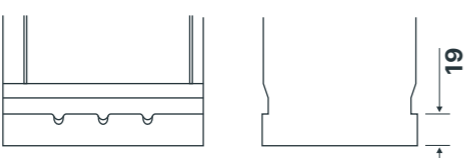
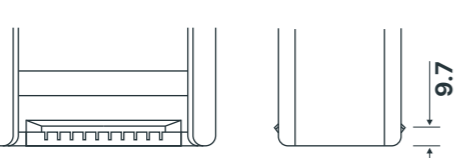
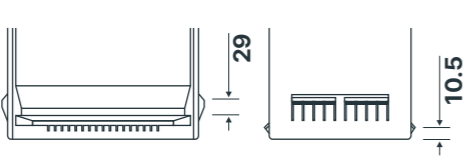
B1		2 Bottom Hold Down 10.5mm high on long sides
B3		4 Bottom Hold Down 10.5mm high on all four sides
B4		2 Bottom Hold Down 19mm high on long sides
B7		2 Bottom Hold Down 9.7mm high on long sides
B9		4 Bottom Hold Down 10.5mm high on long sides 29mm on short sides

BCI FIGURE

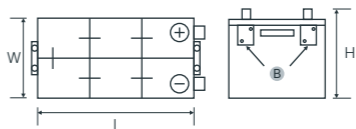
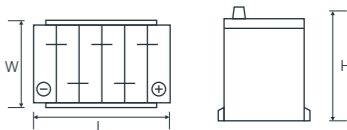
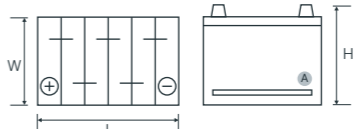
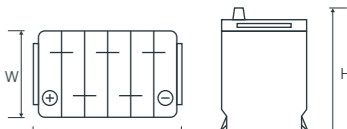
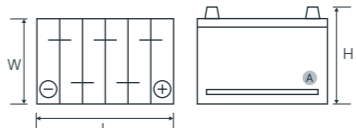
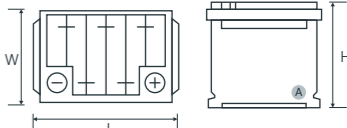
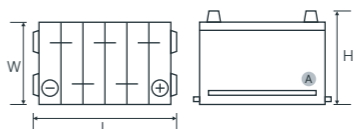
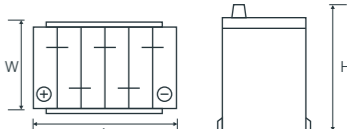
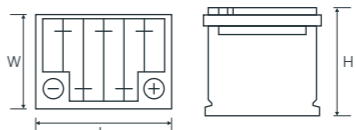
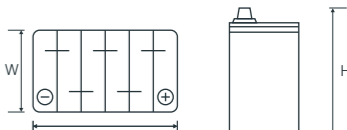
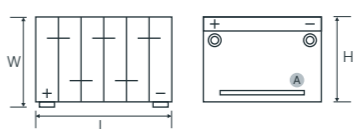
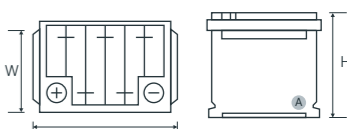
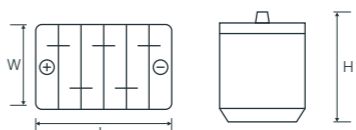
8		19	
10		21	
11		24	
11F		26	
15		28	
17		34	
18			

BATTERY PRINCIPLES AND FEATURES

SELF-DISCHARGE RATE BY TEMPERATURE

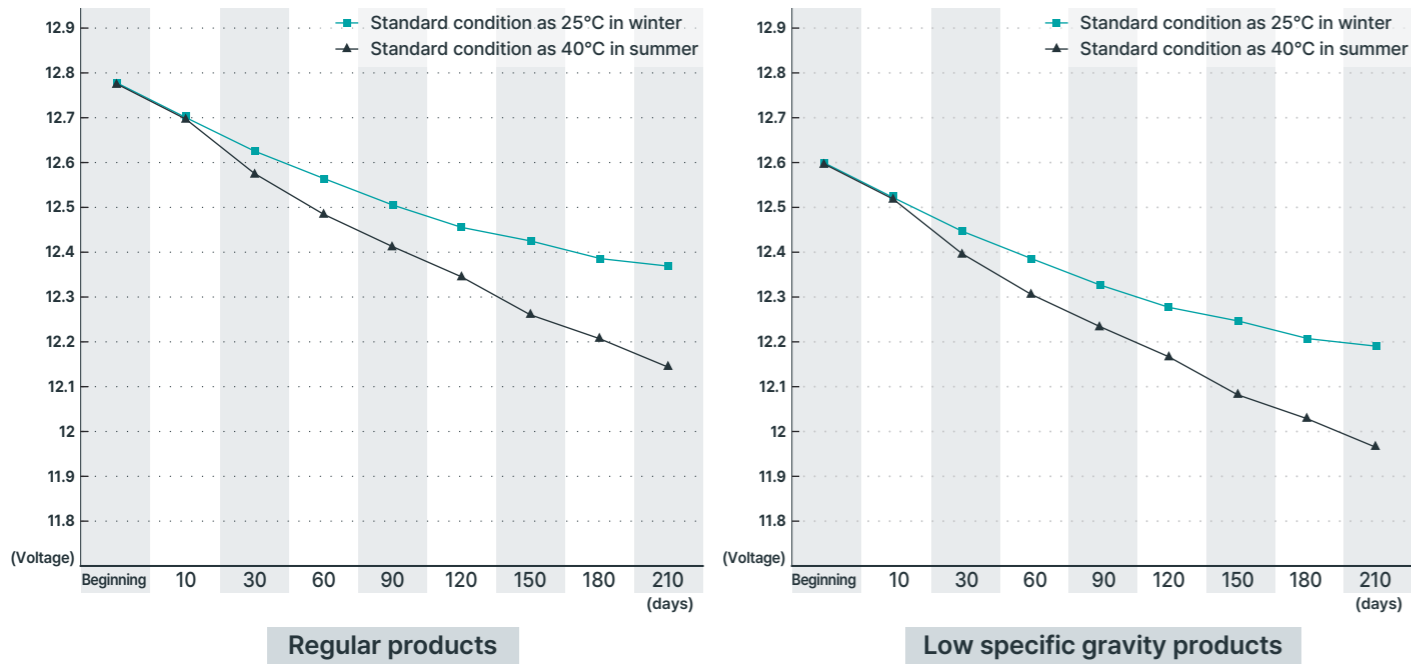

-The higher the temperature, the more battery self-discharged.
 [Self discharge : summer season (April to September) > winter season (October to March)]
 * This data is a test number. It uses as a reference value and it can be changed depending on region and season.

CHANGES IN THE REQUIRED ENGINE STARTING LOAD AND AVAILABLE CAPACITY OF THE BATTERY BY TEMPERATURE

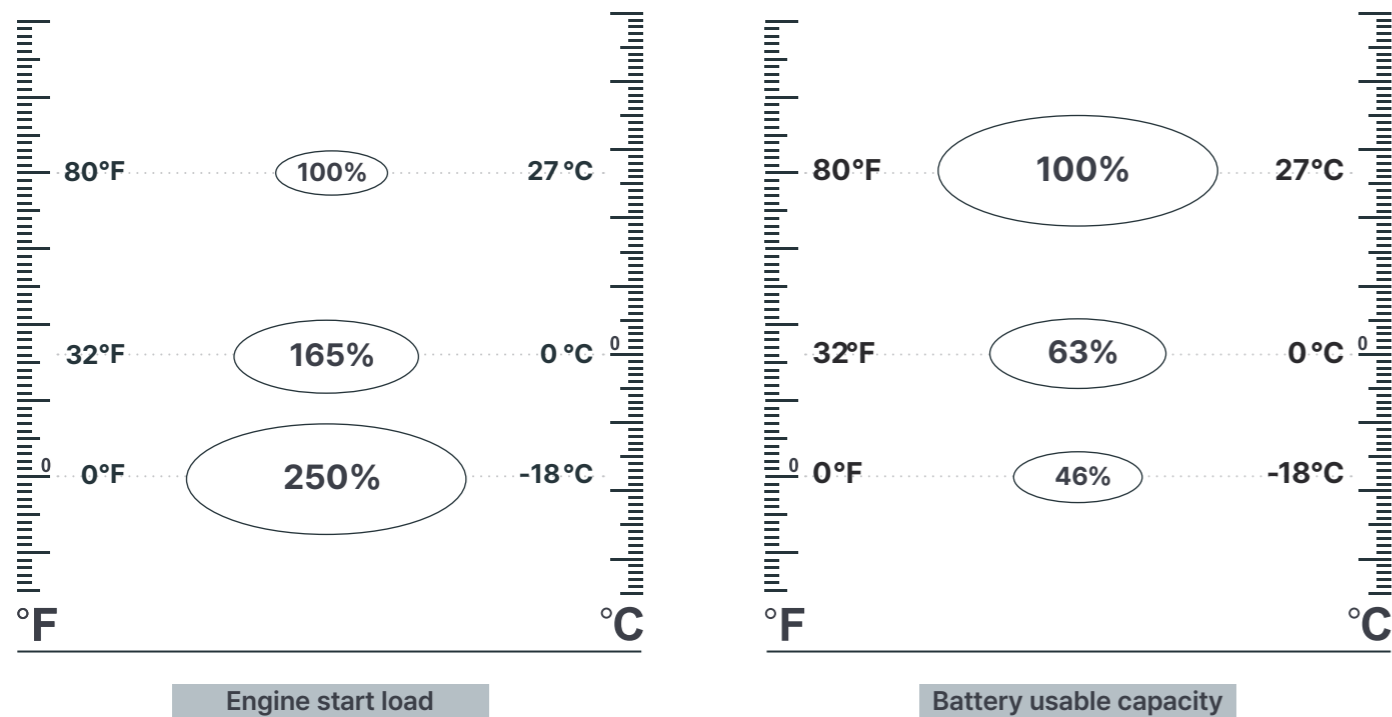

-Batteries increase their usable capacity at higher temperatures
 -The lower the car's engine temperature, the greater the load required to start it.
 ▷ Difficult to start due to bad conditions in both battery and engine starting characteristics at low temperatures

PROCEDURE OF REPLACEMENT

- 

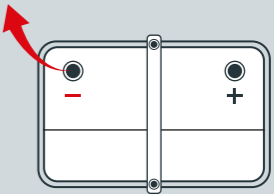
Switch off the engine and Keep sparks, flames, cigarettes away from battery at all times, before removing the old battery.
- 

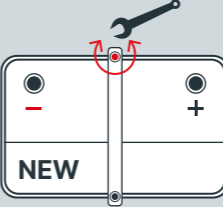
Disconnect the negative terminal, first and avoid short-circuit caused by tools, when removing old battery.
- 

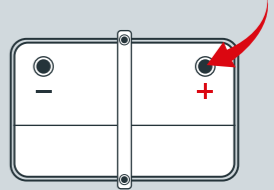
Clean corroded parts in tray and cable clamps, before installation of new battery.
- 

Connect the positive terminal, first and check the terminal clamps for tight fit, when installing new battery.

PRECAUTIONS

- NO SPARKS, FLAMES, OR SMOKING.
- CHARGE IN WELL VENTILATED AREA. REMOVE FROM VEHICLE PRIOR TO CHARGING.
- READ YOUR VEHICLE, BOOSTER, AND BATTERY MANUALS PRIOR TO CHARGING.
- IN CASE OF EXPOSURE TO ACID, FLUSH IMMEDIATELY WITH WATER. THEN GET IMMEDIATE MEDICAL HELP.
- DO NOT BLOCK OR ALTER VENT HOLE.
- KEEP OUT OF REACH OF CHILDREN.

WARNING!

LEAD ACID BATTERIES GENERATE EXPLOSIVE GASES. KEEP SPARKS, FLAMES, & LIGHTED CIGARETTES AWAY FROM BATTERY, WHEN CHARGING OR USING BATTERY IN AN ENCLOSED SPACE, PROVIDE VENTILATION. THIS BATTERY CONTAINS SULPHURIC ACID. AVOID CONTACT WITH SKIN EYES, OR CLOTHING. IN EVENT OF ACCIDENT FLUSH WITH WATER AND CALL A PHYSICIAN IMMEDIATELY.



					
Flammables	Read Instructions Carefully	Keep out of Reach of children	Caution of Sulfuric Acid	Shield Eyes	Explosive