



ENGINEERING DATA SHEET

PLUS ALKALINE BATTERY

Document Title: PB035960

LR14

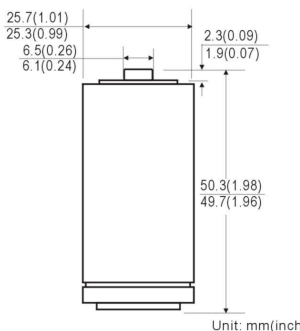

Chemical System : Primary Alkaline
 Zinc-Manganese Dioxide (Zn/MnO₂)
Camelion Model : LR14
IEC No. : LR14
ANSI/NEDA No. : 14A (C)
Average Weight : 66.3g
Dimension (∅ x H) : 25.5^{+0.2} x 50.0^{+0.3} mm
 1.00^{+0.01} x 1.97^{+0.01} inch
Terminals : Flat
Nominal Voltage : 1.5Volts
Average Capacity : 8450 mAh to 0.8 volts
 (20±2°C, Rated capacity at 25 mA continuous drain)
Jacket : Aluminum Foil Label

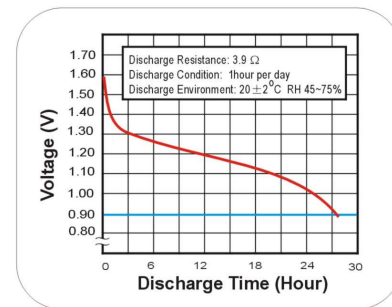
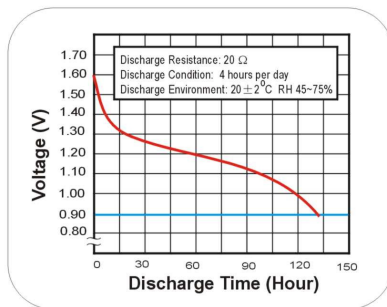
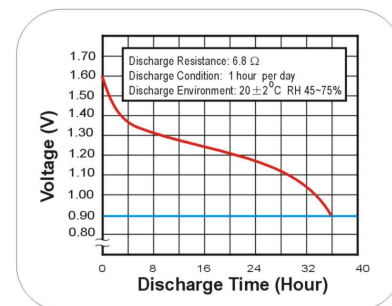
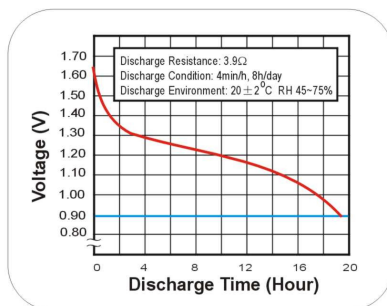

Notice:

Environmental elements comply with RoHS requirements. This information is subject to change without prior notice and for reference only. It should not be used as a basis for a product guarantee or warranty. For additional information, please consult your nearest Camelion Sales Office or Distributor or visit our website at: www.camelionbattery.com.