

## LR14-Digi

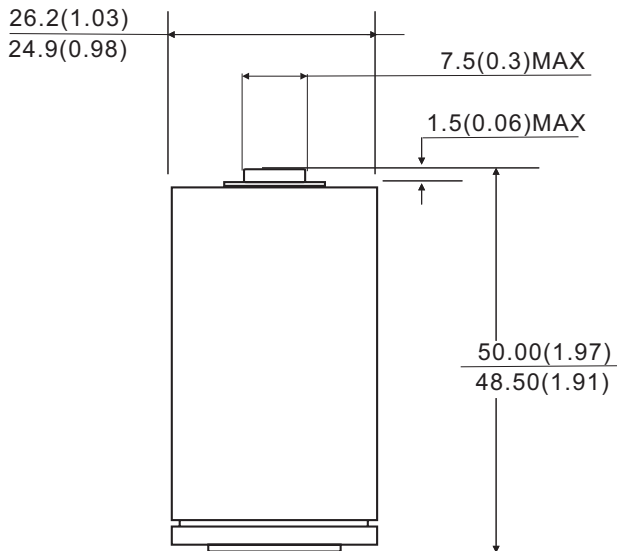

### Dimensions



Unit:mm(inch)

## Digi Alkaline Battery

### Specifications

<b>Chemical System:</b>	Alkaline (Zn/MnO <sub>2</sub> ) Zinc-Manganese Dioxide
<b>IEC Name:</b>	LR14
<b>ANSI/NEDA:</b>	14A (C)
<b>Camelion Model:</b>	LR14-Digi
<b>Average Weight:</b>	72g
<b>Dimension(∅ x H):</b>	25.55 <sup>±0.65</sup> x 49.25 <sup>±0.75</sup> mm 1.01 <sup>±0.03</sup> x 1.94 <sup>±0.03</sup> inch
<b>Terminals:</b>	Flat
<b>Nominal Voltage:</b>	1.5Volts
<b>Capacity:</b>	8500mAh (Rated at 25mA to 0.8V)
<b>Operating Temperature:</b>	-18°C-55°C
<b>Storage Temperature:</b>	15°C-25°C
<b>Relative Humidity:</b>	60±15%
<b>Jacket :</b>	Aluminum Foil Label

### Usage Guide



Radio



Toy



Portable light

### Cautions

#### Storage

Store the battery in a cool, dry and well-ventilated area.

#### Handling

- (1) Never charge the battery. Do not heat or disposed in fire or water. Do not modify or disassemble the battery. Do not short-circuit positive (+) and negative (-) terminals. Keep away from metal or other conductive materials.
- (2) Keep away from infants. If infant happens to swallow the battery, consult a doctor immediately.
- (3) Do not mix use old batteries with new ones, or mix use batteries of different types or brands
- (4) In case the battery electrolyte happen to come into mouth, gargle well enough and consult a doctor immediately.

**Notice:**

Environmental elements comply with RoHS requirements. This information is subject to change without prior notice and for reference only. It should not be used as a basis for a product guarantee or warranty. For additional information, please consult your nearest Camelion Sales Office or Distributor or visit our website at: [www.camelionbattery.com](http://www.camelionbattery.com).

## LR14-Digi

## Digi Alkaline Battery

### Constant Current Discharge

Typical Characteristics at 21°C

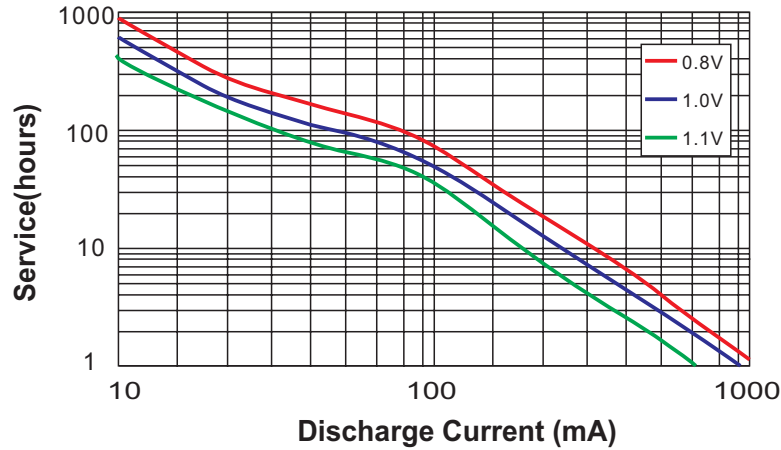

### IEC Standard Testing

Typical Characteristics

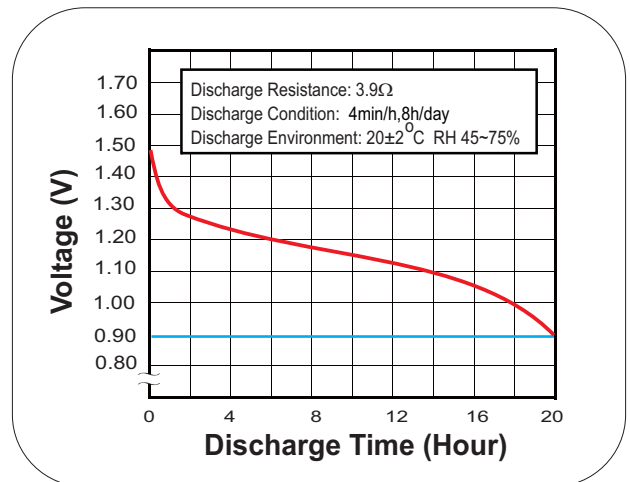
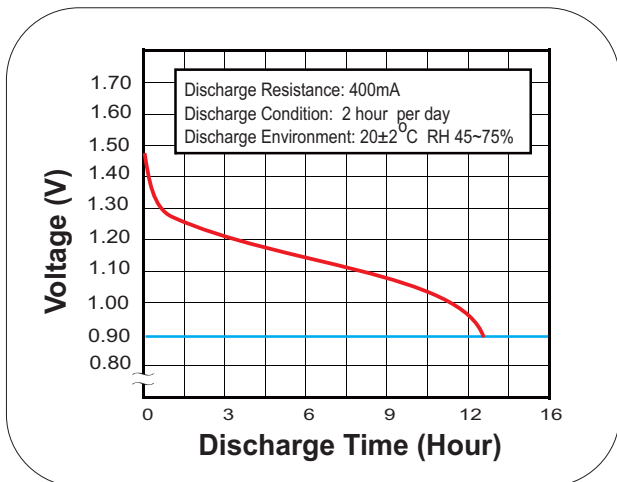
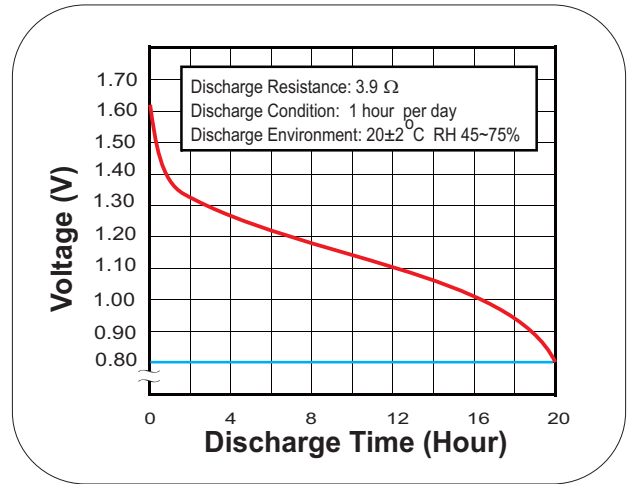
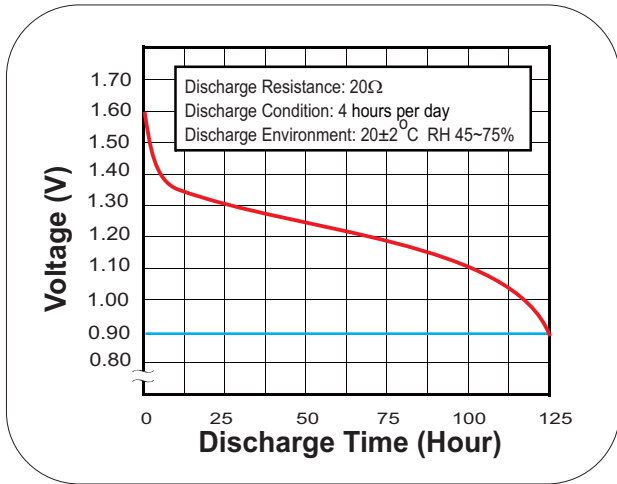

**Notice:**

Environmental elements comply with RoHS requirements. This information is subject to change without prior notice and for reference only. It should not be used as a basis for a product guarantee or warranty. For additional information, please consult your nearest Camelion Sales Office or Distributor or visit our website at: [www.camelionbattery.com](http://www.camelionbattery.com).